

Use of vibratory shear enhanced processing to treat magnetic ion exchange concentrate: A techno-economic analysis

Jack Leong^a, Jace Tan^b, Anna Heitz^c, Bradley P. Ladewig^{a,d*}

^aDepartment of Chemical Engineering, Monash University, VIC 3800, Australia, Melbourne, Australia

^bCurtin Water Quality Research Centre (CWQRC), Department of Chemistry, Curtin University, Bentley, GPO Box U1987, Perth, WA 6845, Australia

^cDepartment of Civil Engineering, Curtin University, Bentley, GPO Box U1987, Perth, WA 6845, Australia

^dDepartment of Chemical Engineering, Imperial College London, Exhibition Road, London SW7 2AZ, United Kingdom

*Corresponding author: Dr Bradley Ladewig, b.ladewig@imperial.ac.uk

Abstract

Disposal of waste generated by inland water treatment technologies is highly expensive. The introduction of vibratory shear enhanced processing (VSEP) to treat waste produced from magnetic ion exchange (MIEX) shows benefits in terms of performance and economics. A small VSEP unit with the potential to treat up to 15kL of MIEX waste per day, is able remove more than 97% of dissolved organic compounds as well as recover over 80% of waste in the form of permeate. The reuse of permeate to makeup brine has seen significant reductions in salt consumption and waste disposal at Wanneroo Groundwater Treatment Plant (GWTP). During the first year of VSEP operation, salt consumption reduced by 42% and waste disposal was projected to reduce by 23.9%. Further improvements in both cost categories were observed in the second year of operation and considering the same trend is followed, the payback period of the project will occur between the 6th and 7th year of operation for discounted analysis and has a positive net present value.

Keywords: vibratory shear enhanced process; VSEP; membrane nanofiltration; techno-economic analysis; magnetic ion exchange, MIEX

1. Introduction

Concentrate management is a significant financial burden across all industries that generate water based wastes. Concentrates can be characterised in terms of concentration, organic content, pH, turbidity, toxicity among other parameters. In any start-up project, concentrate

1 management should be a major consideration and can contribute significantly towards the
2 operating costs.

3
4 Vibratory Shear Enhanced Processing (VSEP) is a technology which applies torsional
5 vibration to a membrane to increase separation and reduce fouling of a membrane. High shear
6 rates at the membrane surface allow solids and foulants to lift off the membrane surface.
7 Suspended colloids are washed away at the same rate as new particles that arrive [1].
8 Dependant on the pressure applied and the filtration rate, the suspension layer thickness can
9 vary. VSEP has been successfully applied in industries ranging from medical, latex
10 concentration, acid clarification, pigment washing and treating groundwater. The high shear
11 process exposes membrane pores for maximum throughput. Reaching rates of the order (1-3)
12 $\times 10^5 \text{ s}^{-1}$ [2].

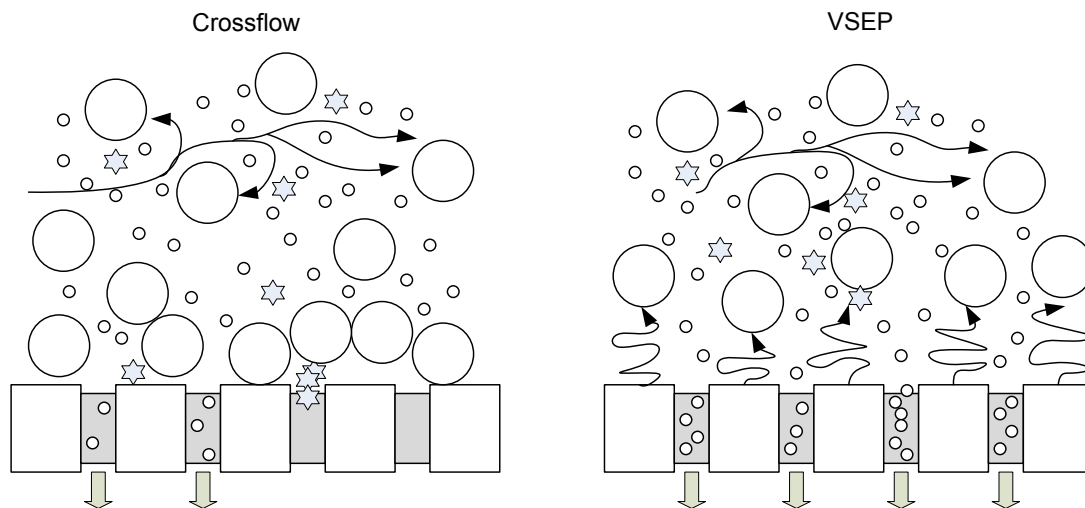

40 Fig. 1. The difference in colloid aggregation in cross flow filtration and VSEP (Image
41 adapted from Johnson) [3]
42

43
44
45 VSEP was used to treat waste generated from a Magnetic Ion Exchange (MIEX) process at
46 the Wanneroo GWTP, Western Australia. MIEX is a technology that uses magnetic beads to
47 remove dissolved organic compounds from groundwater [4]. Resin particles are 150-180 μm
48 and macroporous and contain a magnetized component that allows them to act as weak
49 magnets [5]. The MIEX resin used in this process can be readily regenerated by mixing with
50 high concentrated brine. Within the regeneration phase, waste with high concentrations of salt
51 and organics are produced [6].
52
53
54
55
56
57
58
59
60
61
62
63
64
65

1
2
3
4
5
6
7
8
9
10
11
12
13
14
15
16
17
18
19
20
21
22
23
24
25
26
27
28
29
30
31
32
33
34
35
36
37
38
39
40
41
42
43
44
45
46
47
48
49
50
51
52
53
54
55
56
57
58
59
60
61
62
63
64
65

The capital cost for VSEP equipment consists of multiple structures. Firstly, the filter pack unit is fitted with the membrane and consists of the torsion spring and beatings. The other structure is the motor shaft that drives the movement of the filter pack. A simple VSEP system has a footprint of 1.85 square meters and can accommodate 17.187 m² of membrane area [7].

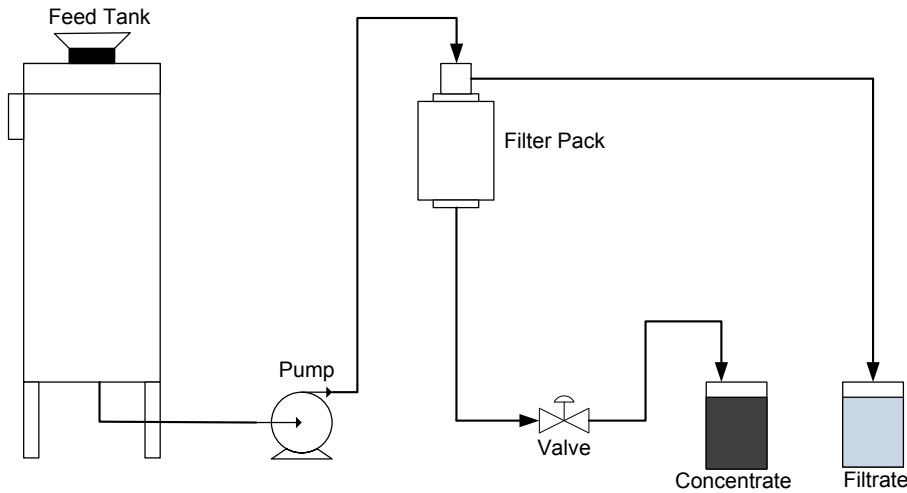

Fig. 2. The basic VSEP system setup (Imaged adapted from Culkin) [8]

Additionally tanks that hold feed and generated permeate are required as part of the VSEP system. Depending on the capacity of the VSEP unit, the sizing of these reservoirs may be different. In this study, the feed tank can hold up to 500kL of MIEX waste and the permeate tank was discharged to a pre-existing storage tank. Furthermore supplementary equipment that contributes to capital include the process logic control (PLC) system for data measurements, online measurement instruments including flow meters and pH monitors, piping and pumps.

Membranes ranging from microfiltration, ultrafiltration, nanofiltration and reverse osmosis have all been considered for use with VSEP [9]. Typically a plate and frame configuration is used in most setups. The setup at Wanneroo incorporates a DOWTech NF-270 membrane in the filter pack. Previous studies have shown that VSEP units convert up to 99% of total shaft energy into shear that acts upon the membrane. This is significantly higher than the 10% conversion offered in conventional cross-flow filtration systems [8].

Although it is comparatively energy efficient, VSEP is recommended for operations dealing with larger volumes. Regardless of the capacity, the same mechanism of shear generation is

1 performed. In cases of low volumes (less than 18.92 Lpm), a significant amount of excess
2 energy may be applied and will consequently result in higher than necessary operating costs
3 [10].
4

5
6 A range of economic analysis has been performed on membrane processes in the past. A
7 study by Owen performed an economic assessment for the treatment of waste water via
8 membrane processes. Results from extensive pilot plant trials of UF and MF membranes
9 determined that the most significant factors to overall cost were membrane cost, membrane
10 replacement frequency and power [11]. The author does not account for additional costs
11 associated with disposal of chemicals though states that treatability of chemicals will be
12 major consideration when selecting a treatment process.
13
14

15
16 A model devised by Sethi et. al, determined the overall economics of crossflow UF and UF
17 processes were associated with raw water quality and resultant permeate flux. Treatment
18 costs were predicted to have relatively lower economies of scale when permeate flux was
19 limited by concentration polarization and cake growth [12]. The VSEP project is dealing with
20 concentrated MIEX waste so it is likely to influence the degree of permeate flux. However
21 the vibrational movements during filtration should minimise the effects of concentration
22 polarization.
23
24

25
26 Another economic analysis on treatment of waste water in a full scale UF plant focussed on
27 determining the sensitivity of total operating cost to changes in total output, filtration time
28 and filtration flux. It was found changes in the permeate output and filtration flux has a
29 significant effect on operating cost [13]. A similar operation was observed in our study where
30 lower filtration flux extended batch times and hence influenced the utilities usage during
31 operation. Permeate output could be altered by changing the overall recovery of the VSEP
32 system but are expected to have less significant influence on operating costs as the changes
33 between settings were small (75, 80 and 85% permeate recovery).
34
35

36
37 Pilot studies involving the treatment of surface water and groundwater using UF and NF
38 membrane processes have yielded results that estimated permeate costs of \$0.15-0.25/m³ [14-
39 17]. It is difficult however to make a direct comparison to this study as the system boundary
40 developed in the performance does not include the initial treatment of groundwater via MIEX.
41
42

43
44 A case study exploring the treatment of concentrate generated from a proposed recycled
45 water facility involved VSEP installation in a multiple system treatment. The pilot scale unit
46
47
48
49
50
51
52
53
54
55
56
57
58
59
60
61
62
63
64
65

was operated for 4 months and determined that the optimal concentrate recovery achieved was 85%. Higher recoveries could be obtained but lower flux rates and higher feed pressure requirements influenced the operation [18].

The economic analysis determined that capital costs included equipment, installation, the SCADA control system, hoist crane hire and labour. Operation and maintenance costs included acid for feed conditioning, membrane replacement along with general utilities and labour costs. The study demonstrated that multiple system designs which incorporated VSEP were significantly cheaper in terms of capital cost than systems incorporating evaporation ponds.

Table 1

The calculated life cycle costs for multiple system design scenarios in Big Bear Valley (adapted from Lozier, in 2007 USD) [19]

Design Scenarios	Capital Cost (\$USD)	Annual O&M Cost (\$USD)	Life Cycle Costs (\$USD)
Evaporation Pond Only + Flow Conveyance + Evaporation Pond	\$13,106,000	\$342,000	\$18,613,000
VSEP + Flow Conveyance + Evaporation Pond	\$6,169,000	\$491,000	\$14,075,000
Effluent Mixing + VSEP + Flow Conveyance + Evaporation Pond	\$6,199,000	\$450,000	\$13,444,000
EMS + Flow Conveyance + Evaporation Ponds	\$9,206,000	\$514,000	\$17,482,000
EDR + Flow Conveyance + Wetlands	\$6,896,000	\$514,000	\$15,172,000
VSEP + Flow Conveyance + Wetlands	\$6,067,000	\$483,000	\$13,844,000
Effluent Mixing + VSEP + Flow Conveyance + Wetlands	\$5,820,000	\$433,000	\$12,792,000

Fig. 3 best describes the VSEP process at Wanneroo GWTP. The key streams entering the system boundaries are the MIEX regeneration waste which is treated via the VSEP system and the make-up salt required to generate the brine medium for MIEX resin regeneration. The two streams that leave the system are the VSEP permeate that has been further processed with make-up salt and the concentrate produced by VSEP that is sent to the waste tank for tankering.

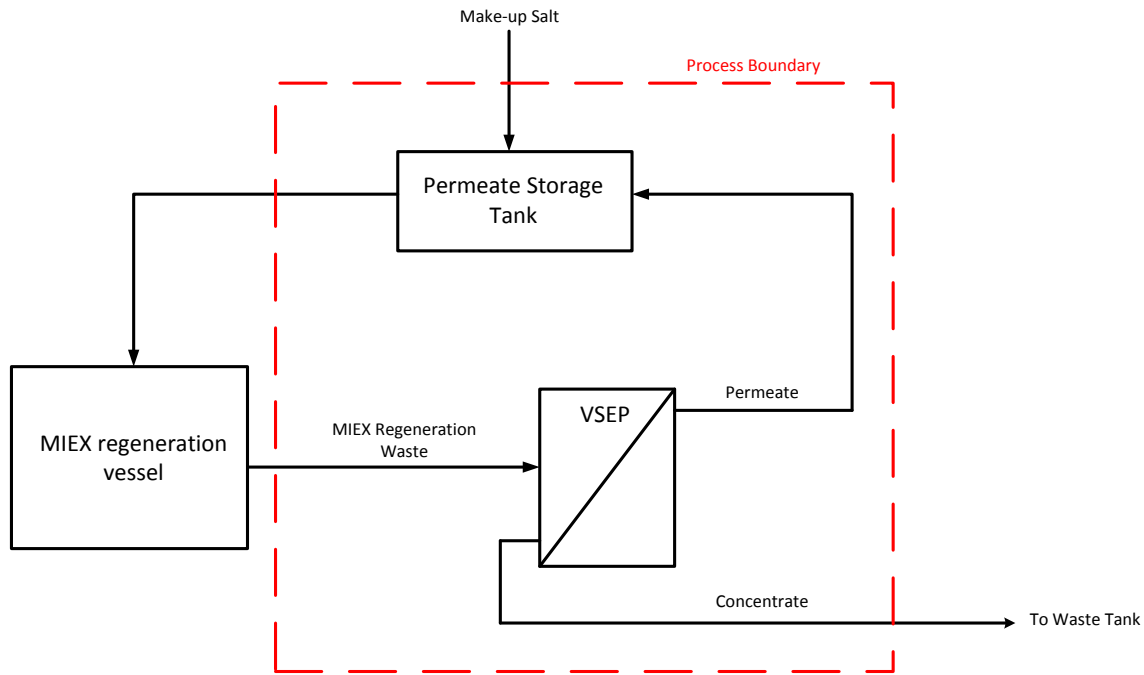

Fig. 3. A process flow diagram showing the system boundary of the installed VSEP established to conduct the economic analysis

The following paper evaluates the economic benefits of the installation of VSEP to treat MIEX waste at Wanneroo GWTP. The influence of flows crossing the system boundary play a substantial role in the determination of financial costs associated with process operation.

2. Materials and Methods

2.1 Materials

The VSEP unit was installed at Wanneroo GWTP. The plant is located approximately 25km north of Perth in Western Australia (-31.722871, 115.852915). The VSEP filter was installed in pilot model (P-mode), a configuration composed of more membranes than when conducted in laboratory mode (L-mode) and is manufactured by New Logic International (USA).

2.2 Method of process operation

In a typical batch cycle, the empty tank is filled to 82.5% volume with the MIEX concentrate. Filtration begins upon reaching this threshold. Filtration occurs with the concentrate stream recycled to the feed tank until the level falls to 22.5-27.5%. The final tank level is governed by the desired batch recovery percentage. When tank level drops below 22.5-27.5%, the system switches into single pass mode via an automated valve and the concentrate stream

1 flows directly to the waste tank. This mode of operation continues until the tank level reaches
2 its minimal threshold of 5% and the filtration ceases. The remaining contents are drained into
3 the same waste tank and the vessel is flushed with process water prior to the next batch [20].
4
5

6 **3. Results**

7 *3.1 Technical performance results*

8
9
10 Operation of VSEP at set permeate recoveries of 75-85% all resulted in over 98% removal of
11 dissolved organic carbon [20]. Molecular weight distribution analysis between the feed and
12 permeate streams showed that the average molecular weight seen in the feed is 1400-1500 Da
13 compared to just 1000 Da in the permeate. Additionally, the rejection studies during the
14 course of the batch showed that the fitted NF-270 membrane was particularly efficient at
15 rejecting solutes with multi-valent charge (>70% rejection) and to a lesser extent monovalent
16 ions such as sodium and chloride (10-20%).
17
18
19
20
21
22
23

24 Results indicated that changing the overall permeate recovery between 75-85% has no
25 significant effects on other performance criteria of the VSEP system at Wanneroo.
26 Additionally pH, temperature and transmembrane pressure had less of an influence on
27 performance between batches.
28
29
30

31
32 However frequency of cleaning was determined to have a significant impact of membrane
33 performance, in particular the permeate flux and batch duration. Frequency settings of 14
34 batches and 16 batches between cleaning were explored. During chemical cleaning, hydrex
35 4703 (acidic) is fed throughout the system to clean the lines and the filter pack. Following the
36 washing, the filter is flushed with Hydrex 4705 (alkaline) which follows with a general flush
37 with process water.
38
39
40
41
42
43

44 In all cases, batches run in a collective sequence indicated a significant deterioration in flux
45 as well as an extension in batch times for batches prior to chemical cleaning. Generally the
46 first three batches following a clean did not show much variation in batch times. This often
47 ranged between 80-95 minutes. However final batch times prior to cleaning often reached
48 above 300 minutes. Consequently, the average flux measured throughout each batch
49 decreased by up to 80-85% between the first and final batch during a cleaning cycle. The
50 decline in flux in NF membrane is likely to be associated with the concentration of feed and
51 scaling. A similar observation relating favoured adsorption of high polarity components in
52 solution was identified in past tests involving NF membranes [21]. It was advised that an
53
54
55
56
57
58
59
60
61
62
63
64
65

1
2
3
4
5
6
7
8
9
10
11
12
13
14
15
16
17
18
19
20
21
22
23
24
25
26
27
28
29
30
31
32
33
34
35
36
37
38
39
40
41
42
43
44
45
46
47
48
49
50
51
52
53
54
55
56
57
58
59
60
61
62
63
64
65

increase in CIP frequency would assist in improving performance. However, increasing the CIP frequency would coincident with an increase in chemical cleaning inventory and operating costs.

3.2 Economic performance results

3.2.1 Assumptions

To conduct economic analysis of the project, some key assumptions were made.

- Project life cycle: 10 years
- There is no cost associated with feedstock as it is a by-product of the existing MIEX regeneration process.
- Previously unused storage tanks were allocated to becoming VSEP feed tanks and permeate tanks and hence did not contribute to the capital cost.
- The plant undergoes 1 month of annual shutdown per year which incorporates maintenance and downtime. Estimated availability of the plant per year is 310 days (85%)

3.2.2 Capital Cost

Capital cost of VSEP installation was provided by IXOM Australia. Costs associated with this figure include the VSEP unit, supporting base, the SCADA control unit, membrane, piping, online instruments, installation and delivery costs and the external shelter.

Table 2

Table comparing the capital costs of the VSEP system to the system pre-installation

CAPEX

Item	VSEP	PRE-VSEP
VSEP module	\$300,000	
Engineering, infrastructure	\$200,000	
<i>Total</i>	\$500,000	0

3.2.3 Operating Cost in first year of operation

Operating costs were provided by the plant operators. Key items contributing to operation costs include:

- Process water: required to flush the system between batches, also used during forced shutdown and routine CIP performance.
- Electricity: required to operate many of the moving parts in the system with the pumps and the motor shaft being the major contributions to power usage.
- Chemicals: Such as Hydrex 4703 and Hydrex 4705. They are currently used every 14-16 batches during routine CIP.
- Labour: During commencement phase, one project manager and one operator was allocated to maintain the performance of the VSEP system. However once trial phase operation was in place, one operator was allocated to the trial as a part time resource. The Total full time equivalent (FTE) operational workload was expected to be in the order of 0.05 FTE.
- Maintenance: Maintenance can include fixing leaks, monthly torque tension check, changing membranes.
- Salt consumption: Defined as the total amount of salt ordered on-site for the MIEX resin regeneration. (Note: salt is not required for VSEP operation)
- Waste Disposal & Transport: Defined as the total amount of waste to be removed from Wanneroo GWTP.

Table 3

Table comparing the operating costs of the VSEP system to the system pre-installation (Treated MIEX waste 2790 kL/year)

Items	VSEP		Pre-VSEP	
	Cost	Units	Cost	Units
Process Water	\$817	\$/yr		
Electricity	\$195	\$/yr		
Chemicals	\$30,915	\$/yr		
Labour	\$13,818	\$/yr		
Maintenance	\$223	\$/yr		
Salt Consumption	\$83,538	\$/yr	\$144,153	\$/yr
Waste Disposal & Transport	\$133,962	\$/yr	\$175,953	\$/yr
<i>Total</i>	\$263,468	\$/yr	\$320,106	\$/yr

The base case operating costs are considered for the MIEX unit alone. Key items from MIEX operation that are influenced by VSEP installation are salt consumption and waste disposal and transport. The alternative, which incorporates the VSEP unit, is the combined MIEX and VSEP case. Figure 3 captures the expected annual operating costs with running the VSEP unit but also shows the savings that are realised as salt consumption is decreased and waste disposal and transport is also decreased, as a result of the volume reduction achieved. To generate the graph, the following points were assumed:

- Feed pressure is constant
- Starting tank volume is the same regardless of recovery setting.
- Process water usage is directly proportionate to volume of waste treated.
- The average VSEP recovery was 80%.

Consistent with literature, operation of VSEP on low recoveries does not generate enough savings to warrant the installation [10]. Furthermore, the need for a plant operator during operation contributes towards the overall OPEX cost. It is beyond 18% permeate recovery that the overall cost benefits of VSEP operation becomes evident (See Fig. 4). Although increased recovery results in higher use of electricity, process water and cleaning chemicals, the reductions in salt consumption by the MIEX and the reduced amount of waste to be disposed are more influential on OPEX cost. Increasing the volume of MIEX waste treated could lead to higher savings, however the operation is limited by the facilities ability to store permeate generated by the VSEP. It should be noted that operation beyond 90% is unrealistic and to reach this values, additional recovery steps such as downstream desalination would need to be implemented.

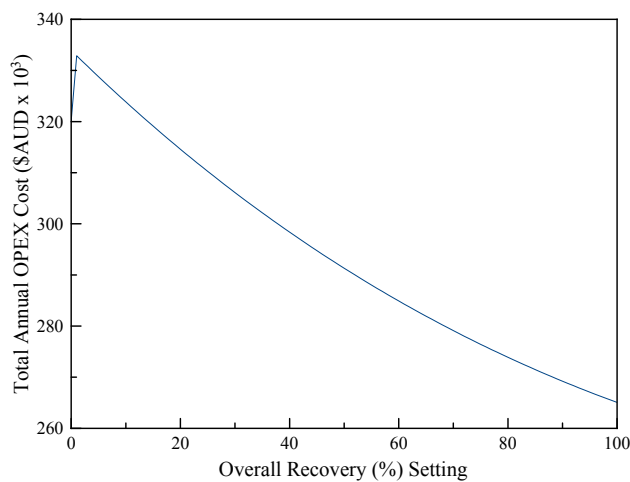

Fig. 4 – Operating cost of VSEP with respect to increasing overall recovery setting

VSEP annual savings with respect to system dependency on

- Concentrate vs permeate

The ratio of concentrate and permeate production is likely to play some effect in VSEP based annual savings. Ideally, one would prefer the majority of the brine content from the feed to be kept in the permeate in order to minimise the volume of concentrate waste that is required to

1
2
3
4
5
6
7
8
9
10
11
12
13
14
15
16
17
18
19
20
21
22
23
24
25
26
27
28
29
30
31
32
33
34
35
36
37
38
39
40
41
42
43
44
45
46
47
48
49
50
51
52
53
54
55
56
57
58
59
60
61
62
63
64
65

be disposed. This was performed via increasing the overall system recovery and was shown to reduce disposal costs (See Figure 4).

- Capacity of VSEP

Currently at Wanneroo GWTP, the VSEP capacity has not been reached. Larger volumes however are likely to result in increased savings as VSEP has previously been shown to be more economically viable when dealing with larger volumes.

- Supply of brine

At Wanneroo GWTP, waste from the MIEX process is held in a storage tank before it is fed through the VSEP. The supply of the brine at Wanneroo is greater enough to meet the capacity of VSEP operation but is not in practice.

- Demand for permeate

The reason why VSEP is not operating at full capacity is largely a result of the demand for permeate at Wanneroo GWTP. The amount of permeate produced by the VSEP exceeds the amount required for the resin regeneration step. Excess permeate is currently held in a storage tank, however there is an action to treat excess permeate via wind aided intensified evaporation (WAIV).

3.2.4 *Life cycle projections*

Fig. 5 shows the projected cumulative cash flow during the life cycle of the VSEP operation. Key assumptions include:

- Project life cycle of 10 years
- Discount rate is 10%
- The current settings of operation are followed over the course of the life cycle ie. Same cash flow each operating year.

The projection curve indicates that the cash flow value at the end of the project of \$66,380 with pay-back occurring 8 years and 10 months after commencement of VSEP use for non-discounted analysis (See Fig. 5). Taking 10% discount rate, the project finishes with a net present value of - \$151,984. The calculated internal rate of return was 2.33%. Based upon first year projections, the installation of VSEP is unlikely to see a positive present value in the given operating cycle.

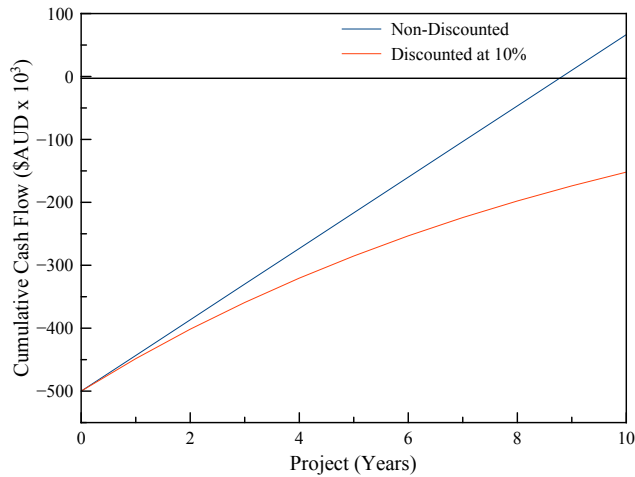
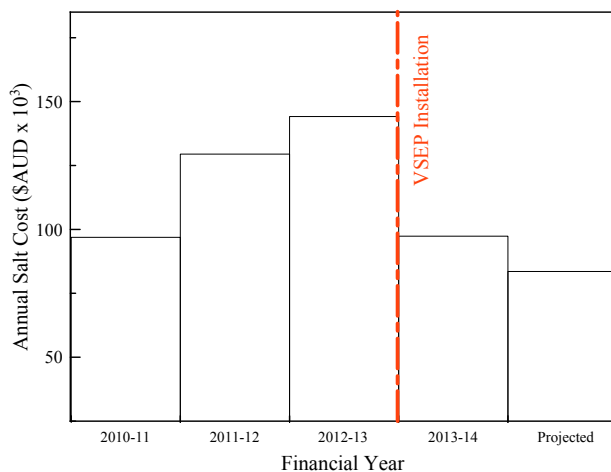

Fig. 5 – Cumulative cash flow of VSEP operation on MIEX waste projected over duration of project life cycle.

3.2.5 Comparison with past operation over the period 2010-2014

Between the years, 2010-2013, salt intake costs increased from \$95,000 AUD to \$144,153AUD (See Fig. 6). The increase in annual cost is largely due to price inflation and increased consumption due to increased groundwater treatment capacity of the plant. The VSEP unit installation was completed in September 2013 allowing for 8 complete months of VSEP operation in the 2013-14 financial year. During the financial year, the cost of salt intake decreased to \$90,000 AUD, a 38% reduction in cost compared to the previous year. It is possible to further decrease the salt intake costs. Projection of the 8 months of VSEP over an entire year results in an estimated annual salt cost of \$83,538 AUD, a 42% reduction.



1
2
3
4
5
6
7
8
9
10
11
12
13
14
15
16
17
18
19
20
21
22
23
24
25
26
27
28
29
30
31
32
33
34
35
36
37
38
39
40
41
42
43
44
45
46
47
48
49
50
51
52
53
54
55
56
57
58
59
60
61
62
63
64
65

Fig. 6 – The annual cost of salt intake during the period 2010-2014 and the projected cost of 2014-2015 based on current data.

Similar trends can also be seen in waste disposal and transport at Wanneroo GWTP during the course of the past 4 financial years (Fig. 7). Interestingly, the most recent financial year (2013-2014) has a waste disposal cost higher than those previously despite the installation of VSEP. However a significant proportion of those tankering costs occurred during the previous months prior to VSEP installation. The projection bar representing the projected costs of waste disposal post-VSEP installation provides an indication of the savings of waste disposal. Compared to the costs in 2012-2013, a projected drop of 23.9% in disposal cost is expected.

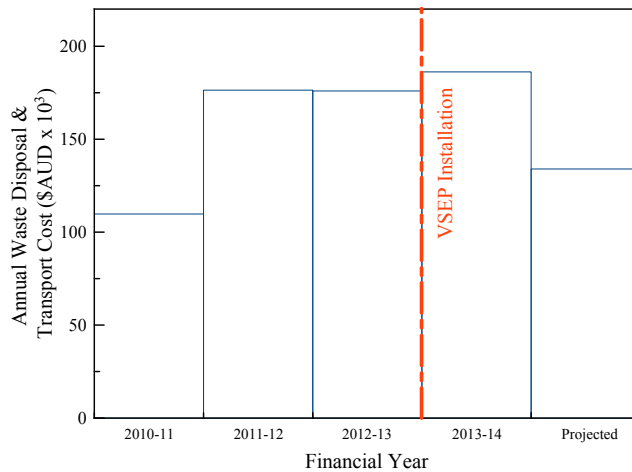

Fig. 7 – The annual cost of waste disposal and transport during the period 2010-2014 and the projected cost of 2014-15 based on current data.

3.2.6 Average Monthly expenses associated with VSEP installation

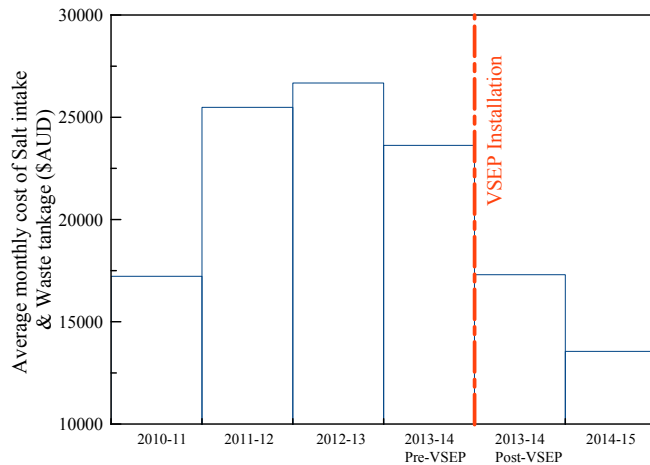

Fig. 8 – The average monthly cost of salt and waste disposal during the period prior and post-VSEP installation

Figure 8 shows the average monthly cost (\$AUD) for intake salt and waste tankage at Wanneroo in the past 5 operational years of operation. The peak cumulative cost occurred in the operating year of 2012-2013. VSEP was installed at Wanneroo during the 2013-2014 which saw noticeable reduction in costs by 35.1% during the 8 months of operation. With VSEP in continuous operation, associated costs of salt and waste further reduced to approximately \$13,500 each month. Compared to the baseline (2012-13), a reduction of 49.2% has been observed. The improvements in associated costs during the VSEP operation years 2013-14 and 2014-15 are likely due to significant improvements in number of commissioning and research related activities. During the first year of operation, the MIEX regeneration system suffered from a broken header resulting in higher than normal resin wastage through to the waste brine. Collectively this prevented the VSEP system from running optimally in 2013-14.

3.2.7 Projected Life Cycle Change After 2 years of operation

Items	VSEP		Pre-VSEP	
	Cost	Units	Cost	Units
Process Water	\$899	\$/yr		
Electricity	\$215	\$/yr		
Chemicals	\$34,006	\$/yr		
Labour	\$3,300	\$/yr		
Maintenance	\$245	\$/yr		
Salt Consumption & Waste Disposal & Transport	\$162,612	\$/yr	\$320,106	\$/yr

<i>Total</i>	\$201,777	\$/yr	\$320,106	\$/yr
--------------	-----------	-------	-----------	-------

Comparatively, the second year of operation resulted in an even more significant reduction in salt consumption and waste disposal costs. The overall operational costs in the second year of operation are 33.2% less than that observed at the baseline. This saving can also be reflected on the life cycle projection curve.

The projection curve indicates that the cash flow value at the end of the project of \$621,599 with pay-back occurring 5 years and 9 months after commencement of VSEP use for non-discounted analysis (See Fig. 9). Taking 10% discount rate, the project has a payback time 6 years and 8 months and finished with a net present value of \$170,998. The calculated internal rate of return was 16.90%.

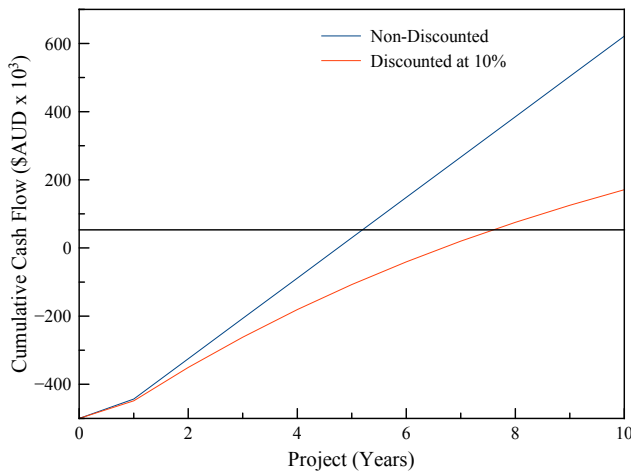

Fig. 9 – Cumulative cash flow of VSEP operation on MIEX waste projected over duration of project life cycle using values obtained after 2 years of operation.

4. Conclusions

Installation of VSEP to treat MIEX waste at Wanneroo GWTP has already shown significant economic savings. During the first year of operation at 80% volumetric capacity, there has been up to \$57,000 AUD saving in terms of salt consumption, waste disposal and transport. The amount of salt consumption and waste disposal has reduced by 42% and 23.9% respectively in comparison to the year prior to VSEP installation. Increasing the volume of waste treated could result in further economic improvements. Cumulative cash flow based upon first year savings indicates that the project has will not reach the net positive payback in the recommended project life cycle. However, projections based on results from the second

1
2 year of operation indicate that faster payback period of 6 years and 8 months as well as a
3 positive net present value of \$170,998AUD.

4 **Acknowledgements**

5
6 The authors acknowledge the financial support of the National Centre of Excellence in
7 Desalination Australia, which is funded by the Australia Government through the Water for
8 the Future Initiative. Michael Jovanoski, Peter Spencer and Troy Jansen of WA Water
9 Corporation kindly provided the process performance and operational cost data. Additional
10 thanks to Brendan Murray of IXOM, for providing capital cost information.

11 **References**

- 12
13 [1] C.V. K.S. Hasan, P.Ariyamethee, S. Chantaraaumpornm, P. Moongkhumklang,
14 Introduction to vibratory shear enhanced membrane processing and its Application in Starch
15 Wastewater Recycle, Liquid Purification Engineering International, (2008).
16
17 [2] M.Y. Jaffrin, Dynamic shear-enhanced membrane filtration: A review of rotating disks,
18 rotating membranes and vibrating systems, Journal of Membrane Science, 324 (2008) 7-25.
19
20 [3] M.M. Johnson Greg, A Comparison of Conventional Treatment Methods and VSEP, A
21 Vibrating Membrane Filtration System, New Logic Research, (2006).
22
23 [4] M.R.D. Mergen, B. Jefferson, S.A. Parsons, P. Jarvis, Magnetic ion-exchange resin
24 treatment: Impact of water type and resin use, Water Research, 42 (2008) 1977-1988.
25
26 [5] M. Kitis, B. İlker Harman, N.O. Yigit, M. Beyhan, H. Nguyen, B. Adams, The removal of
27 natural organic matter from selected Turkish source waters using magnetic ion exchange
28 resin (MIEX®), Reactive and Functional Polymers, 67 (2007) 1495-1504.
29
30 [6] T.V. Nguyen, R. Zhang, S. Vigneswaran, H.H. Ngo, J. Kandasamy, P. Mathes, Removal
31 of organic matter from effluents by Magnetic Ion Exchange (MIEX®), Desalination, 276
32 (2011) 96-102.
33
34 [7] L.M. Vane, F.R. Alvarez, Full-scale vibrating pervaporation membrane unit: VOC
35 removal from water and surfactant solutions, Journal of Membrane Science, 202 (2002) 177-
36 193.
37
38 [8] A.P. B. Culkin, M. Monroe, Solve membrane fouling problems with high-shear filtration,
39 Chemical Engineering Progress, 12 (1998) 29-33.
40
41 [9] M.D. Petala, A.I. Zouboulis, Vibratory shear enhanced processing membrane filtration
42 applied for the removal of natural organic matter from surface waters, Journal of Membrane
43 Science, 269 (2006) 1-14.
44
45
46
47
48
49
50
51
52
53
54
55
56
57
58
59
60
61
62
63
64
65

- 1
2
3
4
5
6
7
8
9
10
11
12
13
14
15
16
17
18
19
20
21
22
23
24
25
26
27
28
29
30
31
32
33
34
35
36
37
38
39
40
41
42
43
44
45
46
47
48
49
50
51
52
53
54
55
56
57
58
59
60
61
62
63
64
65
- [10] W. Shi, M.M. Benjamin, Effect of shear rate on fouling in a Vibratory Shear Enhanced Processing (VSEP) RO system, *Journal of Membrane Science*, 366 (2011) 148-157.
- [11] G. Owen, M. Bandi, J.A. Howell, S.J. Churchouse, Economic assessment of membrane processes for water and waste water treatment, *Journal of Membrane Science*, 102 (1995) 77-91.
- [12] S. Sethi, M.R. Wiesner, Cost modeling and estimation of crossflow membrane filtration processes, *Environmental Engineering Science*, 17 (2000) 61-79.
- [13] M.O. Daramola, K.J. Keesman, Modelling and economic analysis of ultrafiltration units: Case study of a full-scale UF plant, *European Journal of Scientific Research*, 20 (2008) 544-557.
- [14] A. Bick, L. Gillerman, Y. Manor, G. Oron, Economic Assessment of an Integrated Membrane System for Secondary Effluent Polishing for Unrestricted Reuse, *Water*, 4 (2012) 219-236.
- [15] M. Drouiche, H. Lounici, D. Belhocine, H. Grib, D. Piron, N. Mameri, Economic study of the treatment of surface water by small ultrafiltration units, *Water SA*, 27 (2001) 199-204.
- [16] M. Gander, B. Jefferson, S. Judd, Aerobic MBRs for domestic wastewater treatment: A review with cost considerations, *Separation and Purification Technology*, 18 (2000) 119-130.
- [17] R. Liikanen, J. Yli-Kuivila, J. Tenhunen, R. Laukkanen, Cost and environmental impact of nanofiltration in treating chemically pre-treated surface water, *Desalination*, 201 (2006) 58-70.
- [18] U.E. J. Lozier, A. Lynch, S. Schindler, Evaluating Traditional and Innovative Concentrate Treatment and Disposal Methods for Water Recycling at Big Bear Valley, *New Logic Research*, (2007).
- [19] J. Leong, J. Tan, J. Charrois, B.P. Ladewig, Review of high recovery concentrate management options, *Desalination and Water Treatment*, 52 (2014) 7609-7627.
- [20] J. Leong, J. Tan, A. Heitz, B.P. Ladewig, Performance of a vibratory shear membrane filtration system during the treatment of magnetic ion exchange process concentrate, *Desalination*, 365 (2015) 196-203.
- [21] B. Van Der Bruggen, C. Vandecasteele, Flux decline during nanofiltration of organic components in aqueous solution, *Environmental Science and Technology*, 35 (2001) 3535-3540.