

School of Physiotherapy and Exercise Science

**Investigation into the prevalence, spinal kinematics and management of
adolescent male rowers with low back pain**

Leo Ng

**This thesis is presented for the Degree of
Doctor of Philosophy
of
Curtin University**

August 2013

Statement of Originality

To the best of my knowledge and belief, this thesis contains no material previously published by any other person except where due acknowledgement has been made. This thesis contains no material which has been accepted for the award of any other degree or diploma in any university.



Leo Ng
August 2013

Acknowledgements

I now come toward the end of my doctoral studies, and reflect on the *rollercoaster* ride. This ride came with many intellectual, emotional and personal ups and downs, and I do not think it could have happened if not for the many people that have supported me throughout this journey.

Firstly, I would like to acknowledge my supervisors. Professor Peter O'Sullivan, you have taught me so much more than research, low back pain and physiotherapy. I also learned from you how to style my hair, presentation strategies (where a picture is always worth 1000 words), teaching skills, teamwork, leadership and how to keep everything simple. I hope to one day be as simple as you. I thank you for giving me the opportunity to learn from you and hope to continue to do so for the rest of my career.

Dr. Amity Campbell, your enthusiasm could be felt the moment you stepped into the School of Physiotherapy. Your knowledge in the field of biomechanics and your sense of humor at every meeting will forever be ingrained into my head. The motivation you have provided me is a key ingredient to what I have achieved in research. I will forever be grateful and hope to pass your teaching style on to my students.

Dr. Anne Smith, your statistical knowledge and your easy to follow structures in everything that you do are examples I will try to follow from now on. You have joined my supervisory team at the most crucial part of my journey. I do not think the studies would have been the same without your input.

I would also like to thank other important members of the research team. A/Prof Angus Burnett, thank you for starting me on the right track in this journey. Your attention to detail in reviews, your quick turnaround time and your balanced comments as a supervisor, associate editor and a friend are all valued and appreciated. Specialist Sports Physiotherapist JP, thank you for all your help in delivering the intervention to the participants and for your

ongoing support in the final two studies. You have made writing enjoyable and fun, although the many dinners we had prior to our writing sessions have helped me gain a couple of kilos. A/Prof Di Hopper and Prof Leon Straker, both of you have provided much support and motivation during my studies. Paul Davey, Peter McKinnon and Roger Collinson, thank you for providing your technical support and statistics expertise. I have learned a lot from each and every one of you.

I would also like to thank the rowing coaches, rowers and their parents who have been involved with the studies. I have had the pleasure of learning from all of you; the dingy rides at 5:30am were ... memorable.

I have also had a lot of help from my friends (and I include my work colleagues here), although not all of them have helped me with the PhD directly, their ongoing support throughout these 7 years to make sure I maintained a somewhat balanced life is appreciated.

To my family, you have been there to celebrate every success and ride out every challenge that came with the PhD. To my mum and dad, you have supported me even during your toughest hours. I know I have not spent as much time as I should during dad's battle with cancer, but lesson learned! I only hope that I can be half as good as you two are as parents in the future. Bennie, you have always been a brother I look up to. I know that half my success belongs to you for always pushing yourself academically and this has rubbed off on me. To Bailey and Dougie (my dogs), you two have been watching me the whole way to make sure I get my work done. Lastly, to my wife Christine, we have only known each other for a short time, but you have supported me so much during this period and I am so lucky to have found you. I cannot wait to start the next chapter of our lives, and I hope you will always be there to remind me, that family comes first!



Abstract

There is a high prevalence of low back pain (LBP) in adolescent female rowers. However, to date the prevalence of LBP in adolescent male rowers has not been reported. Relatively little is known about the mechanisms that contribute to LBP in adolescent rowers. The repeated cyclic motion involving large ranges of lumbar flexion and extension has been suggested as a risk factor linked with the high rates of LBP reported. The prevalence of LBP in this population is important, as LBP during adolescence is known to be a risk factor for LBP in adulthood.

Limited research has investigated whether a relationship between LBP and rowing kinematics exists. Further, it is unknown as to whether there are differences in lumbar kinematics between adolescent male and female rowers during rowing. Understanding this is important for the development of coaching techniques and targeting treatment strategies for LBP. Those studies that have investigated lumbar kinematics during ergometer rowing have typically utilised pain free populations and a single lumbar region segment. Recent evidence suggests that regional lumbar kinematics (upper and lower lumbar spine regions) should be explored, with comparisons between healthy and LBP populations necessary. Finally, two clinical trials have shown that a targeted cognitive functional approach to the management of LBP is effective in reducing LBP prevalence, pain intensity and disability utilising cohorts of adolescent female rowers. However, neither study was conducted as a randomised controlled trial and to date the effects of such treatment programs in adolescent male rowers remain unknown.

Therefore, the broad aims of this doctoral study were to

- i) Investigate the prevalence, pain intensity and risk factors associated with LBP in adolescent male rowers and compare this with results from adolescent female rowers.

- ii) Confirm the validity of using an electromagnetic motion analysis system to measure regional spinal kinematics during ergometer rowing.
- iii) Compare differences in pelvic, regional lumbar and thoracic spinal kinematics between adolescent male and female rowers during ergometer rowing.
- iv) Determine whether regional lumbar kinematics of rowers differ between adolescent males with and without LBP during ergometer rowing.
- v) Determine the efficacy of a targeted cognitive functional therapy program in reducing LBP and disability. This includes investigation as to whether this intervention alters; lower limb and back muscle endurance, habitual sitting postures and hip and spino-pelvic kinematics during ergometer rowing.

This thesis consisted of six studies. Firstly, a questionnaire was used to determine the lifetime and point prevalence of LBP, pain intensity and aggravating factors in adolescent male rowers. The data was compared with a previously published thesis on age matched adolescent female rowers. The results showed a significantly higher lifetime prevalence of LBP in adolescent male rowers (93.8%: 127/135) compared to adolescent female rowers (77.9%: 183/235)($p < 0.001$) and also a higher point prevalence of LBP in males (64.6%: 84/130) than females (52.8%: 124/235)($p < 0.001$). Adolescent male rowers reported significantly lower self-reported pain intensity using a visual analogue scale (4.1/10) compared to females (5.0/10)($p = 0.003$). Both groups identified similar rowing related factors that provoked LBP, with the exception that fewer males reported lifting the rowing shell to aggravate their LBP. The results of this study promote further research into determining the underlying mechanisms of LBP and developing pain management strategies for adolescent rowers.

The second study aimed to determine the validity of a motion analysis system (3-Space Fastrak™) in investigating regional spinal kinematics during ergometer rowing. The study compared the angles of a wooden spine

derived from this motion analysis system with angles derived from an inclinometer that were taken on a normal Concept II ergometer and on a modified ergometer with ferrous metal replaced with non-ferrous material. The results of this study showed that the mean regional spinal kinematics collected by the 3-Space Fastrak™ when used on a normal Concept II ergometer was significantly different ($p=0.007$) than the reading on an inclinometer, whilst the angle on the modified ergometer was statistically equivalent to the inclinometer with a 0.4° error ($p=0.660$). This study demonstrates the validity of using an electromagnetic motion analysis system to determine regional spinal kinematics using a modified ergometer composed of only non-ferrous material such as wood.

In the third study, pelvic, regional lumbar and thoracic spinal kinematics of 10 pain free adolescent male and 10 adolescent female rowers during ergometer rowing were compared. The results of this study demonstrated that adolescent male rowers had significantly less anterior pelvic tilt and greater thoracic flexion compared with adolescent female rowers ($p<0.05$). Males were also found to have a significantly shorter drive phase than adolescent female rowers ($p=0.001$). It was proposed that the differences in kinematics of the pelvis and lower thoracic angles between genders during ergometer rowing may represent different LBP risk mechanisms for adolescent male and female rowers.

The fourth study used a cross sectional design to compare differences in regional lumbar kinematics in the sagittal plane between 10 adolescent male rowers with LBP and 10 adolescent male rowers without LBP during a 15-minute ergometer row. The results showed that adolescent male rowers with pain reported a gradual increase of LBP intensity during a 15-minute ergometer row [estimated increase of 0.41/10 on the Numeric Pain Rating Scale (NPRS) per minute]. No differences were found in the mean regional lumbar kinematics between rowers with and without LBP ($p>0.05$), however rowers with LBP postured their upper lumbar spine closer to end of range flexion in a larger proportion of their drive phase than rowers with no-LBP ($p=0.021$) and had greater variability in both their lower lumbar and upper

lumbar angle during ergometer rowing. The results of this study suggest that altered regional lumbar kinematics during ergometer rowing may be a risk factor for the development of LBP.

In the fifth study, 36 rowers with LBP participated in a randomised controlled trial (with blind assessor) to determine the efficacy of a targeted cognitive functional approach in the management of LBP in adolescent male rowers. Nineteen rowers were randomly allocated to the intervention group and received an 8-week program targeting: patient-centred education regarding rowing specific pain mechanisms and training of lumbo-pelvic control in sitting, squatting, lifting and rowing. This training was progressed to enhance conditioning specific to these tasks. Seventeen rowers received their usual coaching care with no input from the physiotherapist involved with the study. Rowers in the intervention group reported a significant improvement in pain during ergometer rowing as measured by the NPRS post intervention ($p=0.008$) compared to the non-intervention group. Further, the intervention group reported a reduction in disability at post-intervention and at 12-week follow-up, as measured by the Roland Morris Disability Questionnaire ($p=0.003$) and Patient Specific Functional Scale ($p=0.01$) compared to the non-intervention group. The intervention group also demonstrated significant improvements in lower limb endurance ($p=0.031$) and a more upright static sitting posture in the lower lumbar angle ($p=0.007$) when compared with the control group. While there was no statistically significant difference ($p=0.054$) in back muscle endurance between groups, the observed increase of 28.2s is potentially clinically meaningful. No differences were detected in the regional lumbar kinematics during ergometer rowing ($p>0.05$). This study supports the use of a cognitive functional approach to reduce LBP in adolescent male rowers.

In the final study, the targeted cognitive functional approach for the management of LBP was implemented on a single male rower from the intervention who reported the most severe LBP and highest level of disability from the randomised control trial. Following the intervention the rower experienced a reduction in pain during ergometer rowing and reduced

disability following the intervention. The rower also utilised a greater proportion of his available range of regional lumbar spine movement during ergometer rowing; improvements were also seen in lower limb and back muscle endurance. The results of this study further support the proposition that a cognitive functional intervention can successfully reduce pain and disability in rowers. The results also suggest that this clinical change may be related to altered spinal kinematics during ergometer rowing for some individuals following a cognitive functional intervention.

Publications in peer reviewed journals

- **Ng L**, Perich D, Burnett A, Campbell A, O'Sullivan P. Self-reported prevalence, pain intensity and risk factors of low back pain in adolescent rowers. *Journal of Science and Medicine in Sport* (in press).
- **Ng L**, Burnett A, O'Sullivan P, Campbell A. Caution: The use of an electromagnetic device to measure trunk kinematics on rowing ergometers. *Sports Biomechanics* 2009. 8(3): 255-259.
- **Ng L**, Campbell AC, Burnett A, O'Sullivan P. Gender differences in trunk and pelvic kinematics during prolonged ergometer rowing in adolescents. *Journal of Applied Biomechanics* 2013. 23(2): 180-187.
- Cañeiro JP*, **Ng L***, Burnett A, Campbell A, O'Sullivan P. Cognitive functional therapy for the management of low back pain in an adolescent male rower: a case report. *Journal of Orthopaedic & Sports Physical Therapy* 2013. 43(8): 542-554.

*denotes equal contribution to the manuscript

Research Grants

- Physiotherapy Research Foundation tagged Sports Physiotherapy Australia Grant worth \$8400 AUD – The title of the project is '*Efficacy of a specific physiotherapy intervention to alter spinal kinematics and reduce low back pain in adolescent male rowers*'. (2009)
 - See Appendix A

Publications in peer-reviewed conference proceeding

Oral Presentation

- **Ng L**, Burnett A, O'Sullivan P. Gender differences in motor control of the trunk during prolonged ergometer rowing. 26th International Conference on Biomechanics in Sports; July 14-18, 2008; Seoul, South Korea.
 - See appendix B

(Awarded – International Student Travel Award)

Poster Presentation

- **Ng L**, Burnett A, O'Sullivan P. Spino-pelvic kinematics and trunk muscle activation in prolonged ergometer rowing: mechanical etiology of non-specific low back pain in adolescent rowers. 26th International Conference on Biomechanics in Sports; July 14-18, 2008; Seoul, South Korea.
 - See appendix B

Conference presentations and abstracts

- **Ng L**, Perich D, Burnett A, O'Sullivan P. Prevalence of low back pain in adolescent rowers. Australian Physiotherapy Association, Brisbane, October, 2011. Pg. 120.
 - See Appendix C

(Awarded - Best 5 x 5 presentation in Sports Physiotherapy Group)

- **Ng L**, Burnett A, Campbell A, O'Sullivan P. Gender differences in spinal kinematics during prolonged ergometer rowing in adolescence, Brisbane, October, 2011 Pg. 98.
 - See Appendix C
- Caneiro JP, **Ng L**, Campbell A, Burnett A, O'Sullivan P. Classification-based cognitive functional intervention to alter spinal kinematics and reduce low back pain in an adolescent rower: A case report, Brisbane, October, 2011. Pg. 98.
 - See Appendix C

Table of Contents

STATEMENT OF ORIGINALITY	II
ACKNOWLEDGEMENTS.....	III
ABSTRACT.....	V
PUBLICATIONS IN PEER REVIEWED JOURNALS	X
RESEARCH GRANTS	XI
PUBLICATIONS IN PEER-REVIEWED CONFERENCE PROCEEDING	XI
TABLE OF CONTENTS.....	XIII
LIST OF TABLES	XVII
LIST OF FIGURES.....	XIX
LIST OF ABBREVIATIONS.....	XXII
CHAPTER 1 – INTRODUCTION	23
1.1 STATEMENT OF THE PROBLEM	25
1.2 RESEARCH QUESTIONS.....	25
1.3 REFERENCES.....	27
CHAPTER 2 - LITERATURE REVIEW.....	30
2.1 INTRODUCTION	30
2.2 DATA SOURCES AND SEARCH STRATEGIES.....	30
2.3 PREVALENCE OF LOW BACK PAIN	31
2.3.1 <i>Definition of LBP</i>	31
2.3.2 <i>Prevalence Period</i>	31
2.3.3 <i>Age</i>	33
2.3.4 <i>Gender</i>	34
2.3.5 <i>Athletic populations/subgroups</i>	35
2.3.6 <i>Back pain in rowing</i>	36
2.3.7 <i>Summary</i>	43
2.4 RISK FACTORS OF LOW BACK PAIN IN ROWERS.....	44
2.4.1 <i>Introduction</i>	44
2.4.2 <i>Physical Factors</i>	44

2.4.3.1	<i>Rowing specific factors</i>	45
2.4.3.2	<i>Individual Factors of LBP in rowers</i>	48
2.4.3.3	<i>Gender specific risk factors</i>	57
2.4.4	<i>Summary</i>	58
2.5	MANAGEMENT OF LOW BACK PAIN IN ROWERS	59
2.5.1	<i>Introduction</i>	59
2.5.2	<i>Cognitive functional therapy for Management of LBP in rowers</i>	59
2.5.6	<i>Summary</i>	65
2.6	REFERENCES	66
CHAPTER 3 - STUDY 1		78
3.1	ABSTRACT	79
3.2	INTRODUCTION	80
3.3	METHODS	81
3.4	RESULTS	84
3.5	DISCUSSION	88
3.6	CONCLUSION	92
3.7	PRACTICAL IMPLICATIONS	92
3.8	ACKNOWLEDGEMENTS	92
3.9	REFERENCES	93
CHAPTER 4 - STUDY 2		97
4.1	ABSTRACT	98
4.2	INTRODUCTION	99
4.3	METHODS	99
4.4	RESULTS	102
4.5	DISCUSSION AND IMPLICATIONS	103
4.6	CONCLUSION	104
4.7	REFERENCES	105
CHAPTER 5 - STUDY 3		106
5.1	ABSTRACT	107
5.2	INTRODUCTION	108
5.3	METHODS	109
5.4	RESULTS	113
5.5	DISCUSSION	115
5.6	ACKNOWLEDGEMENT	120
5.7	REFERENCES	121

CHAPTER 6 - STUDY 4.....	125
6.1 ABSTRACT.....	126
6.3 METHODS.....	129
6.4 RESULTS.....	135
6.5 DISCUSSION	144
6.6 CONCLUSION.....	146
6.7 FINDINGS	147
6.8 IMPLICATIONS.....	147
6.9 REFERENCES	148
CHAPTER 7 - STUDY 5.....	154
7.1 ABSTRACT.....	155
7.2 INTRODUCTION	156
7.3 METHODS.....	158
7.4 RESULTS.....	167
7.5 DISCUSSION	173
7.6 CONCLUSION.....	178
7.7 ACKNOWLEDGEMENT.....	178
7.8 REFERENCES	179
7.9 SUPPLEMENTARY MATERIAL.....	184
CHAPTER 8 - STUDY 6.....	193
8.1 ABSTRACT.....	194
8.2 INTRODUCTION	196
8.3 CASE DESCRIPTION	197
8.4 OUTCOME MEASURES	202
8.5 INTERVENTION.....	207
8.6 OUTCOMES	208
8.7 DISCUSSION	210
8.8 CONCLUSION.....	213
8.9 ACKNOWLEDGEMENT.....	213
8.10 REFERENCES	214
8.11 SUPPLEMENTARY MATERIAL.....	220

CHAPTER 9 – DISCUSSION AND CONCLUSION.....	227
9.1 DISCUSSION AND CONCLUSION.....	227
9.2 FUTURE STUDIES.....	232
9.3 REFERENCES	234
APPENDIX A – RESEARCH GRANT	237
APPENDIX B – CONFERENCE PROCEEDING	238
APPENDIX C – CONFERENCE ABSTRACTS AND PRESENTATIONS.....	248
APPENDIX D – ETHICAL APPROVAL.....	251
APPENDIX E – INFORMATION SHEETS.....	252
APPENDIX F – CONSENT FORM.....	254
APPENDIX G – LOW BACK PAIN & ROWING QUESTIONNAIRE	256
APPENDIX H – ETHICAL APPROVAL.....	258
APPENDIX I – INFORMATION SHEETS	259
APPENDIX J – CONSENT FORMS	261
APPENDIX K – BORG RATES OF PERCEIVED EXERTION SCALE	263
APPENDIX L – SCREENING QUESTIONNAIRE	264
APPENDIX M – ROLAND-MORRIS DISABILITY QUESTIONNAIRE	267
APPENDIX N – PATIENT SPECIFIC FUNCTIONAL SCALE.....	268
APPENDIX O – ETHICAL APPROVAL.....	269
APPENDIX P – INFORMATION SHEETS.....	270

List of Tables

Chapter 2 – Literature review

<i>Table 2.1 – The lifetime prevalence of LBP between specific sporting population and no-sports group</i>	37
<i>Table 2.2 Studies of prevalence / incidence of LBP in rowers</i>	40
<i>Table 2.3 – Summary of spinal kinematics research in rowers</i>	55
<i>Table 2.4 Details of a targeted cognitive functional approach for Management of LBP in rowers</i>	61

Chapter 3 – Study 1

<i>Table 3.1 – Prevalence of LBP in adolescent rowers between genders</i>	85
<i>Table 3.2 – Self reported rowing related aggravating factors to LBP between genders</i>	87

Chapter 4 – Study 2

<i>Table 4.1. Fastrak™ output from a standard ergometer and a modified ergometer compared with inclinometer reading</i>	102
---	-----

Chapter 5 – Study 3

<i>Table 5.1 – Differences in slouch sitting angles between genders</i>	114
<i>Table 5.2 - Gender and time comparison of trunk and pelvic kinematics during drive phase</i>	116

Chapter 6 – Study 4

<i>Table 6.1 – Mean and standard deviation of characteristics in each group and the mean, standard error and p-value of differences between the no pain and pain group</i>	136
<i>Table 6.2 - Mean and standard deviation of the lower and upper lumbar angles for drive phases over 1st 7th and 15th minute, for Pain and No Pain group</i>	137

<i>Table 6.3 - Mixed model coefficients for lower and upper lumbar angle</i>	138
<i>Table 6.4 - Percentage of drive phase in greater than 80% of flexion range for Lower and upper angle, for Pain and No Pain group</i>	141
<i>Table 6.5 - Mixed model results for proportion of drive phase in >80% lower and upper lumbar end range flexion</i>	142

Chapter 7 – Study 5

<i>Table 7.1 – unadjusted mean baseline characteristics between control and intervention group</i>	169
<i>Table 7.2 – Unadjusted Secondary Outcomes at baseline, 8-week follow up and 12-week follow up and estimated group difference adjusted for baseline measures and age</i>	172

Chapter 8 – Study 6

<i>Table 8.1 – Outcome measures and kinematics data at pre-intervention, post-intervention and at 12-weeks follow up</i>	205
--	-----

List of Figures

Chapter 2 – Literature review

<i>Figure 2.1 – the median prevalence of LBP with interquartile range in point, 1-month, 1-year and lifetime prevalence</i>	32
<i>Figure 2.2A – Lifetime prevalence of LBP by age between males and females</i>	34
<i>Figure 2.2B – Point prevalence of LBP by age</i>	34
<i>Figure 2.3 – The median prevalence of LBP with interquartile ranges according to their age groups</i>	35
<i>Figure 2.4 – The incidence of LBP in adolescent female rowers during different parts of the rowing season for the intervention group</i>	39
<i>Figure 2.5A – Catch position during ergometer rowing</i>	46
<i>Figure 2.5B – Finish position during ergometer rowing</i>	46
<i>Figure 2.6A – Lower lumbar kinematics (% of full range flexion) of cyclists with LBP and with no-LBP over a 120-minute cycling task</i>	50
<i>Figure 2.6B Average pain score (as measured by the Numeric Pain Rating Scale) of cyclists with pain during a 2-hour cycling task</i>	50
<i>Figure 2.7 Rowing exercises in the physiotherapy intervention program</i>	62
<i>Figure 2.8 Point prevalence of LBP between intervention and no-intervention group during the rowing season</i>	64

Chapter 3 – Study 1

<i>Figure 3.1 – Self reported pain intensity between adolescent male and female rowers</i>	86
--	----

Chapter 4 – Study 2

- Figure 4.1 - Fastrak source and sensor positions on a wooden spine on a modified ergometer (with ferrous material replaced with wood)* 101
- Figure 4.2 – The variability of Sensor 3 during one rowing cycle. The rise in angles on the standard ergometer coincided with the source and sensors moving past the foot of the standard ergometer* 104

Chapter 5 – Study 3

- Figure 5.1 - Raw (left) and slouch corrected (right) angles of the PA, LLA, ULA and LTA during the drive phase of the 1st and 20th minute of a rowing stroke for males and females during ergometer trial* 117

Chapter 6 – Study 4

- Figure 6.1A – Catch position during ergometer rowing* 130
- Figure 6.1B – Finish position during ergometer rowing* 130
- Figure 6.2 – Regional lumbar kinematics (ULA – Upper Lumbar Angle; LA –LLA – Lower Lumbar Angle)* 133
- Figure 6.3 – Group mean and standard deviation of low back pain intensity scores (measured by Numeric Pain Regional Scale) during the 15-minute rowing ergometer trial* 136
- Figure 6.4 – Lower lumbar angle for each subject over the 1st, 7th and 15th minute, for the early, mid and late drive phase separately, in pain and no pain groups separately* 139
- Figure 6.5 – Upper lumbar angle for each subject over the drive phase separately for 1st, 7th and 15th minute, in pain and no pain groups separately* 137
- Figure 6.6A: Proportion of drive phase lower lumbar angle in greater than 80% flexion over 1st, 7th and 15th minute, in pain and no pain groups separately* 143
- Figure 6.6B: Proportion of drive phase upper lumbar angle in greater than 80% flexion over 1st, 7th and 15th minute, in pain and no pain groups separately* 143

Chapter 7 – Study 5

<i>Figure 7.1 – Multidimensional classification system for low back pain (LBP) in adolescent male rowers in the intervention group</i>	162
<i>Figure 7.2 – Regional lumbar kinematics</i>	165
<i>Figure 7.3 – flow chart depicting participant recruitment, randomisation allocation to CFT intervention and control group and retention of participants.</i>	168
<i>Figure 7.4 – Numeric pain rating scale during ergometer rowing at pre-intervention laboratory analysis and post-intervention laboratory analysis between the control and the intervention groups.</i>	171

Chapter 8 – Study 6

<i>Figure 8.1 - This figure provides a comparison between the athlete's usual movement strategy (upright/rigid posture with co-contracted trunk muscles) and the new movement strategy (relaxed thoraco-lumbar region and relaxed trunk muscles) during ergometer rowing</i>	200
<i>Figure 8.2 - Flow chart describing the different levels of the Multidimensional Classification System</i>	202
<i>Figure 8.3 - Hip, pelvic and trunk kinematics (ULA – Upper Lumbar Angle; LA – Lumbar Angle; LLA – Lower Lumbar Angle; SA – Sacral Angle; HA – Hip Angle)</i>	206
<i>Figure 8.4 - Numeric Pain Rating Scale during ergometer rowing at pre-intervention laboratory analysis (Initial) and post-intervention laboratory analysis (Follow up)</i>	209
<i>Figure 8.5 - Hip, pelvic and trunk kinematics of the drive phase during the 1st minute of the rowing ergometer trial. Where positive angles indicate flexion angles (anterior pelvic tilt of the SA) and negative angles indicate extension angles (posterior pelvic tilt)</i>	210

List of Abbreviations

LBP	low back pain
CFT	cognitive functional therapy
y	years
SD	standard deviation
MRI	magnetic resonance imaging
BME	back muscle endurance
LLME	lower limb muscle endurance
SPSS	Statistical Package for the Social Science
3D	three-dimensional
PA	pelvic angle
SA	sacral angle
LLA	lower lumbar angle
ULA	upper lumbar angle
LTA	lower thoracic angle
ICC	intra-class correlation
ANOVA	analysis of variance
95% CI	95% confidence interval
SPM	strokes per minute
VAS	visual analogue scale
BMI	body mass index
RMDQ	Roland Morris disability questionnaire
PSFS	patient specific functional scale
NPRS	numeric pain rating scale
kg	kilograms
ht	height
%ile	percentile
EMG	electromyography

Chapter 1 – Introduction

Low back pain (LBP) is a common disorder that is experienced by up to 80% of adults at some point in their life.^{2,26} Compounding this problem, up to 60% (range of 44-78%) of this population experience a relapse in pain after one episode,¹³ between 10-23% develop chronic LBP (pain duration is more than 12 weeks)¹ and an estimated 10.7% report a high level of disability associated with LBP.⁸ More recently, the Global Burden of Disease study has ranked LBP to have the highest years lived with *disability* worldwide.²⁵ The high prevalence of individuals with LBP and the presence of chronic and disabling LBP have resulted in this condition being associated with one of the largest economic costs to society, and this cost is suggested to be growing.⁹

The sport of rowing has gained popularity in the past few decades.²¹ It is considered a physically demanding exercise¹¹ and as a consequence is thought to provide physical and mental health benefits to participants.^{4,27} The increase in participation has led to more research identifying that LBP is common in rowers.^{14,15,28} Of greatest concern is the high prevalence of LBP in adolescent rowers, where the development of LBP in this age group has led to participants quitting the sport,²³ and LBP in adolescents is recognised as a major risk factor for the development of LBP in adulthood.^{3,5,12,16}

There remains a paucity of literature investigating risk factors for LBP in rowers. The amount of time spent on ergometer rowing has been linked with LBP,^{22,23,28} with several researchers suggesting that lumbar kinematics during ergometer rowing is associated with LBP.^{6,7,20,29} However, none have attempted to verify the direct relationship between pain and ergometer rowing to date. An investigation of lumbar kinematics between participants with and without LBP is a necessary starting point. However, a system for measuring regional lumbar kinematics during ergometer rowing has not been validated. Further, given that there are different muscle characteristics,¹⁷ sitting postures¹⁰ and spino-pelvic kinematics during ergometer rowing¹⁸

between healthy adult males and females, there may potentially be different risk factors and treatment strategies between genders. There is also a need to investigate regional spino-pelvic kinematics during ergometer rowing in the adolescent male population with pain, as there appears to be a gap in the literature in this group. Understanding the risk factors associated with this group of rowers is important so that more targeted research aimed at injury management can be conducted.

Whilst there have been a number of treatment protocols recognised to manage LBP disorders in the general population, limited research has been performed with the rowing sub-population. To date, two studies have investigated the efficacy of cognitive functional therapy (CFT) in reducing LBP intensity and disability in adolescent female rowers.^{19,24} Both studies demonstrated this to be an effective intervention, however neither were conducted as a randomised controlled trial. Further, given the differences in physical characteristics between genders,^{10,17,18} treatment strategies that were proven effective in the management of LBP in adolescent female rowers^{19,24} may not be effective for their male counterparts.

Therefore, the overall aims of this doctoral investigation were to investigate the self-reported prevalence of LBP, pain intensity and aggravating factors of LBP between adolescent male rowers and to compare this with existing data from adolescent female rowers. Further, the series of studies compared regional spino-pelvic kinematics between adolescent male and female rowers; and between adolescent male rowers with and without LBP. Finally, the studies evaluated the effectiveness of targeted cognitive functional therapy in reducing LBP and disability. It sought to determine the ability of such programs to alter muscle endurance, habitual sitting postures and regional spino-pelvic kinematics during ergometer rowing.

1.1 Statement of the problem

The prevalence of LBP in adolescent female rowers is high and the aetiology of LBP is complex. The factors associated with LBP in adolescent rowers must be understood if prevention or treatment programs are to be implemented successfully. However, there is a current dearth of information regarding the prevalence and risk factors of LBP in adolescent male rowers. More importantly, there have been no published reports of interventions in relation to LBP in the specific subpopulation of adolescent male rowers.

1.2 Research questions

Study One: Self-reported prevalence, pain intensity and risk factors for low back pain in adolescent rowers

- What is the prevalence of LBP in adolescent male rowers?
- Is the prevalence of LBP different in adolescent male rowers compared to adolescent female rowers?
- What are the rowing specific aggravating factors identified by adolescent male rowers to be associated with LBP?

Study Two: Caution: The Use of an Electromagnetic Device to Measure Spinal Motion on Rowing Ergometers

- Is an electromagnetic motion analysis system that is capable of capturing real time spinal kinematics valid in measuring regional spinal kinematics during ergometer rowing?

Study Three: Gender differences in trunk and pelvic kinematics during prolonged ergometer rowing in adolescents

- Are there differences in spino-pelvic kinematics during ergometer rowing between adolescent male and female rowers?

Study Four: Spinal kinematics of adolescent male rowers with back pain in comparison to matched controls during ergometer rowing

- Are there differences in regional lumbar kinematics between adolescent male rowers with and without LBP?

Study Five: Cognitive functional therapy to manage low back pain for rowers: a randomised controlled trial

- Is a targeted physiotherapy intervention able to reduce LBP during ergometer rowing and disability in adolescent male rowers in a randomised controlled trial?
- Can such intervention change lower limb muscles and back endurance, usual sitting posture and regional lumbar kinematics during ergometer rowing in a group of adolescent male rowers with LBP?

Study Six: Cognitive functional therapy for the management of low back pain in an adolescent male rower: a case report

- Is a targeted physiotherapy intervention able to reduce LBP during ergometer rowing and disability, as well as improving lower limb and back muscle endurance, static sitting posture and regional lumbar kinematics during ergometer rowing in an adolescent male rower with high pain intensity and disability?

1.3 References

1. Andersson HI, Ejlertsson G, Leden I, Rosenberg C. Chronic pain in a geographically defined general population: studies of differences in age, gender, social class, and pain localization. *The Clinical Journal of Pain*. 1993;9(3):174-182.
2. Balague F, Dutoit G, Waldburger M. Low back pain in schoolchildren. An epidemiological study. *Scandinavian Journal of Rehabilitation Medicine*. 1988;20(4):175-179.
3. Balague F, Troussier B, Salminen JJ. Non-specific low back pain in children and adolescents: risk factors. *European Spine Journal*. 1999;8(6):429-438.
4. Biddle SJH, Gorely T, Stensel DJ. Health-enhancing physical activity and sedentary behaviour in children and adolescents. *Journal of Sports Sciences*. 2004;22:679-701.
5. Brattberg G. Do pain problems in young school children persist into early adulthood? A 13-year follow-up. *European Journal of Pain*. 2004;8(3):187-199.
6. Bull AMJ, McGregor AH. Measuring spinal motion in rowers: the use of an electromagnetic device. *Clinical Biomechanics*. 2000;15(10):772-776.
7. Caldwell JS, McNair PJ, Williams M. The effects of repetitive motion on lumbar flexion and erector spinae muscle activity in rowers. *Clinical Biomechanics*. 2003;18(8):704-711.
8. Cassidy JD, Carroll LJ, Cote P. The Saskatchewan health and back pain survey. The prevalence of low back pain and related disability in Saskatchewan adults. *Spine*. 1998;23(17):1860-1867.
9. Dagenais S, Caro J, Halderman S. A systematic review of low back pain cost of illness studies in the United States and internationally. *The Spine Journal*. 2008;8(1):8-20.
10. Dunk NM, Callaghan JP. Gender-based differences in postural responses to seated exposures. *Clinical Biomechanics*. 2005;20(10):1101-1110.

11. Hagerman FC, Fielding RA, Flatarone MA, Gault JA, Kirkendall DT, Ragg KE, et al. A 20-yr longitudinal study of Olympic oarsmen. *Medicine & Science in Sports & Exercise*. 1996;28(9):1150-1156.
12. Hestbaek L, Leboeuf-Yde C, Kyvik KO, Manniche C. The course of low back pain from adolescence to adulthood: eight-year follow-up of 9600 twins. *Spine*. 2006;31(4):468-472.
13. Hestbaek L, Leboeuf-Yde C, Manniche C. Low back pain: what is the long-term course? A review of studies of general patient populations. *European Spine Journal*. 2003;12(2):149-165.
14. Hickey GJ, Fricker PA, McDonald WA. Injuries to elite rowers over a 10-yr period. *Medicine & Science in Sports & Exercise*. 1997;29(12):1567-1572.
15. Hosea TM, Hannafin JA. Rowing injuries. *Sports Health*. 2012;4(3):236-245.
16. Jeffries LJ, Milanese SF, Grimmer-Somers KA. Epidemiology of adolescent spinal pain: a systematic overview of the research literature. *Spine*. 2007;32(27):2630-2637.
17. Mannion AF, Dumas GA, Cooper RG, Espinosa FJ, Faris MW. Muscle fibre size and type distribution in thoracic and lumbar regions of erector spinae in healthy subjects without low back pain: normal values and sex differences. *Journal of Anatomy*. 1997;190(4):505-513.
18. McGregor AH, Patankar ZS, Bull AMJ. Do men and women row differently? A spinal kinematic and force perspective. *Proceedings of the Institution of Mechanical Engineers. Part P, Journal of Sports Engineering and Technology*. 2008;222(2):77-83.
19. Perich D, Burnett A, O'Sullivan F, Perkins C. Low back pain in adolescent female rowers: A multi-dimensional intervention study. *Knee Surgery, Sports Traumatology and Arthroscopy*. 2011;19(1):20-28.
20. Pollock CL, Jones IC, Jenkyn TR, Ivanova TD, Garland SJ. Changes in kinematics and trunk electromyography during a 2000 m race simulation in elite female rowers. *Scandinavian Journal of Medicine & Science in Sports*. 2012;22(4):478-487.

21. Rumball JS, Lebrun CM, Di Ciacca SR, Orlando K. Rowing injuries. *Sports Medicine*. 2005;35(6):537-555.
22. Smoljanovic T, Bojanic I, Hannafin JA, Hren D, Delimar D, Pecina M. Traumatic and overuse injuries among international elite junior rowers. *The American Journal of Sports Medicine*. 2009;37(6):1193-1199.
23. Teitz CC, O'Kane J, Lind B, Hannafin JA. Back pain in intercollegiate rowers. *The American Journal of Sports Medicine*. 2002;30(5):674-679.
24. Thorpe A, O'Sullivan P, Burnett A, Caneiro J-P. Assessing the efficacy of a specific physiotherapy intervention for the prevention of low back pain in female adolescent rowers: A field study. *New Zealand Journal of Sports Medicine*. 2009;32(2):38-46.
25. Vos T, Flaxman AD, Naghavi M, Lozano R, Michaud C, Ezzati M, et al. Years lived with disability (YLDs) for 1160 sequelae of 289 diseases and injuries 1990-2010: a systematic analysis for the Global Burden of Disease Study 2010. *Lancet*. 2012;380(9859):2163-2196.
26. Walker BF. The prevalence of low back pain: a systematic review of the literature from 1966 to 1998. *Journal of Spinal Disorders*. 2000;13(3):205-217.
27. Whelton SP, Chin A, Xin X, He J. Effect of aerobic exercise on blood pressure: a meta-analysis of randomized, controlled trials. *Annals of Internal Medicine*. 2002;136(7):493-503.
28. Wilson F, Gissane C, Gormley J, Simms C. A 12-month prospective cohort study of injury in international rowers. *British Journal of Sports Medicine*. 2010;44(3):207-214.
29. Wilson F, Gissane C, Gormley J, Simms C. Sagittal plane motion of the lumbar spine during ergometer and single scull rowing. *Sports Biomechanics*. 2013;12(2):132-142.

Chapter 2 - Literature Review

2.1 Introduction

The worldwide lifetime prevalence of low back pain (LBP)(presence of pain at least one point in life) is reported to range from 4.7% to 84%.^{22,38} The point prevalence rate of LBP (presence of LBP at a particular point in time) ranges from 5.3% to 39.3%.^{40,93} Despite the large variability in results, it is generally acknowledged that approximately 80% of adults experience LBP at some stage in their life.^{8,119} The disparities in the reported prevalence of LBP between studies are related to varying factors. For instance, discrepancies in the definitions of LBP (location, sensation, frequency, duration and intensity), age and gender of the cohort and specific sub population (such as athletes) have differed between studies and therefore affect the LBP prevalence reported.^{27,29,44,50,119} Understanding how these factors influence prevalence is important in order to correctly recognize the extent of the problem and the risk factors associated with LBP within a population.

2.2 Data sources and search strategies

The databases PubMed, Medline, Proquest Health, Web of Science and Google Scholar were scrutinised from the earliest entry up until July 2013. Various combinations of the following keywords; 'row', 'oar', 'rowers', 'adolescence', 'back pain', 'prevalence of back pain', 'biopsychosocial model', 'sporting activity', 'kinematics', 'gender differences' and 'cognitive functional therapy'. Key authors were also identified as those referred by other researchers to have numerous publications in the field of rowing. A subsequent search was made by the author name. Examples of key authors in the field of rowing are McGregor, Perich, Pollock, Teitz and Wilson. Further, a manual retrospective search of each article's reference list was used to find any suitable references not yet identified by database searches.

2.3 Prevalence of Low Back Pain

2.3.1 Definition of LBP

LBP is defined differently between studies, making comparison of results difficult.^{27,44,49,50,119} It has been proposed that the definition of LBP should be sufficiently detailed such that the location, sensation, intensity of the pain and chronicity of pain are outlined.²⁷ The most accepted location for LBP is between T12 and the inferior gluteal folds.⁴ The definition of sensation should specify whether it is best described as a pain, ache or discomfort.⁹⁵ Dionne et al (2008) suggested that a minimum intensity for an episode of LBP be included in the definition, i.e. 'was your pain bad enough to limit your usual activities?'.²⁷ The chronicity of pain should also be considered in the definition of LBP. For example some studies have investigated prevalence rates in acute LBP while others examined chronic LBP.^{75,84} An acute LBP episode is usually defined as pain and discomfort that persists for less than 6 weeks, whilst chronic LBP is usually defined as pain persisting for 12 or more weeks.¹¹⁶ It is therefore important to consider how LBP was defined, when reviewing the prevalence literature.

2.3.2 Prevalence Period

Differences in the prevalence period for experiencing pain (i.e. lifetime vs point) influence the LBP rate reported.^{27,44} While lifetime prevalence and point prevalence are most commonly reported,^{49,50} several studies have also reported period prevalence (whether the individuals experienced pain in a certain period of time, for example 1-year, 1-month or 1-week prior to data collection).⁵⁵ The prevalence of LBP is higher when the time frame captured is longer.⁴⁹ This is clearly presented graphically in figure 2.1 from Hoy et al (2012) who compared the LBP prevalence rates between 4 different periods in a systematic review of 165 studies over 54 countries between the years of 1980 to 2009.⁴⁹

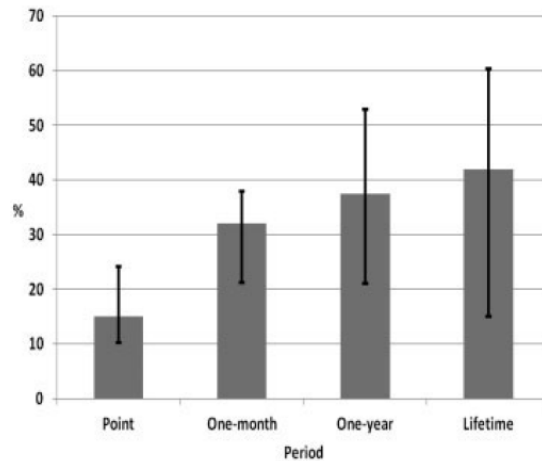

Figure 2.1 – the median prevalence of LBP with interquartile range in point, 1-month, 1-year and lifetime prevalence. (Figure from Hoy et al., 2012)⁴⁹

There are advantages and disadvantages associated with the various prevalence measures (i.e. point, period and lifetime). One of the main advantages of measuring lifetime prevalence is that it is simple and the question has high consistency between studies (e.g. ‘have you ever had low back pain?’). However, the disadvantage is that it requires participants to recall a past experience, and >5 year recall periods are known to have reduced validity.¹⁸ While point prevalence removes this ‘recall’ bias by asking about LBP at the time of data collection, it may not capture LBP that is intermittent in nature and provoked by specific activities (i.e. not present at the exact time of data collection). The period prevalence (e.g. 1-week, 1-month, 6 months) of LBP may limit the recall bias associated with long time frames, while likely capturing those with intermittent pain provoked by activities that are carried out on weekly or monthly basis (such as pain provoked only when rowing). Regardless of the prevalence period reported, it is difficult to discriminate between acute and chronic episodes of LBP and whether or not LBP was recurring. Therefore some studies also report incidence rate, where the frequency of LBP episodes for a certain period of time are reported.⁵⁵ The advantage of reporting incidence rate is that it can be used in prospective studies and be recorded as episodes of LBP occur, however prospective studies generally involve a greater cost in follow-up data collection and are often subject to participant attrition. Given the contrasting advantages and disadvantages between the various prevalence

periods, the most comprehensive solution adopted by the majority of researchers is to utilize at least two prevalence periods (e.g. lifetime prevalence and point prevalence). It is important for meta-analyses and studies comparing more than one population to use the same time period between groups.

2.3.3 Age

Low back pain is rarely reported before the age of 7,¹¹⁴ however LBP is a common complaint in school children and adolescents above this age.^{56,75,84,90} It has been consistently demonstrated that LBP prevalence rates increase with age through adolescence until adulthood.^{29,37,40,44,50,56,90} A comprehensive cross sectional cohort study of 29,424 people between the ages of 12-41 demonstrated this increase in lifetime and point prevalence of LBP during the adolescent years (Figure 2.2A and 2.2A).⁵⁶ This study used a questionnaire that clearly defined LBP and included a diagrammatic representation of the location of LBP, a definition of different sensations of LBP (i.e. pain, tenderness, stiffness or other discomfort) and a question regarding the frequency and duration of each instance (Figure 2.2A and 2.2 B).

Understanding the extent of LBP in the adolescent age group has been recognized as critical, as the development of LBP during this period of life is one of the major risk factors for LBP in adulthood.^{10,13,41,50}

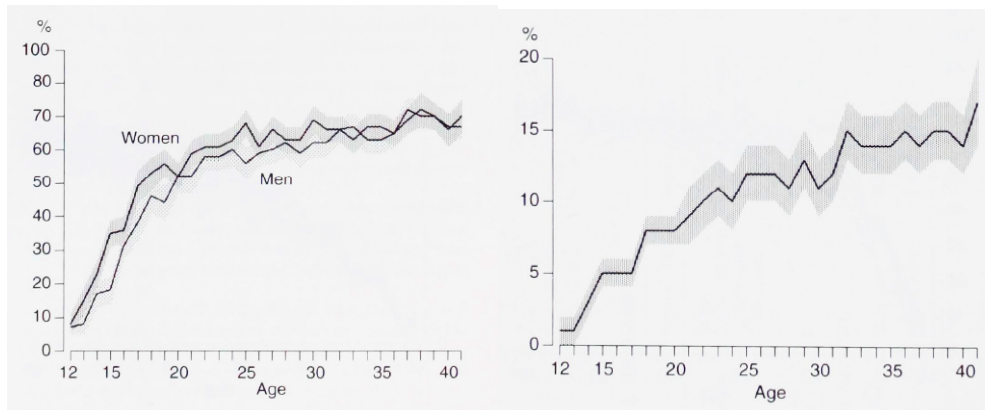

Figure 2.2A – Lifetime prevalence of LBP by age between males and females, **Figure 2.2B** – Point prevalence of LBP by age (Figure from Leboeuf-Yde, 1988)⁵⁶

2.3.4 Gender

There is a general consensus in the literature that females have a higher LBP prevalence than males in both adult and adolescent populations.^{40,49,56,75,84,90} Figure 2.3 illustrates the consistently higher prevalence of LBP in females than males in all age groups from 10 – 89 years old seen in a comprehensive systematic review (54 countries, 165 Papers).⁴⁹ Furthermore, female adolescents were reported to have a higher prevalence of severe LBP (difference of 10.8 - 12.2%)⁴⁰ and chronic LBP (difference of 12.4%) than males during adolescence.⁷⁵

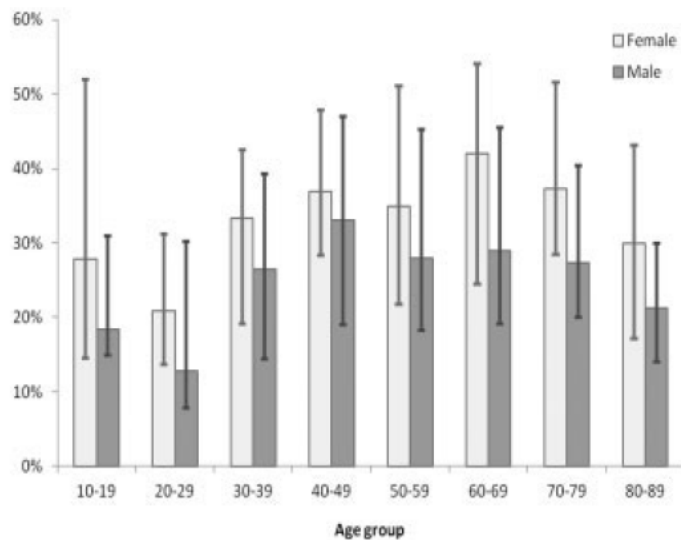

Figure 2.3 – The median prevalence of LBP with interquartile ranges according to their age groups. (Figure from Hoy et al., 2012)⁴⁹

However there is some evidence that reported gender differences may vary depending on the sub-population being investigated. For example, Burton et al (1996) reported a significantly greater lifetime prevalence of LBP in 15+ year old males compared to females in a 5-year prospective longitudinal study on 216 school children.¹⁸ It was reported that this result may have been confounded by the male participant’s higher exposure to strenuous sports than the females.¹⁸ This confounding influence of physical activity levels on LBP prevalence in gender comparisons was also noted in another study (n=98).⁵³ Therefore, investigations comparing LBP between genders should attempt to match the groups according to their participation level in physical activity.

2.3.5 Athletic populations/subgroups

Identifying subgroups of the population that might be at increased risk of LBP has been recognized as a useful strategy in order to highlight where further preventative research and understanding is required. Current research documents that certain athletic populations have a higher reported rate of LBP prevalence compared to the general population.^{83,91,108} For example, Sato et al (2011) reported a greater lifetime prevalence of LBP in

school children participating in a range of different sporting activities outside of school compared to those that did not participate in sports outside of school (table 2.1).⁹¹ Sward et al (1991) reported a lifetime prevalence of LBP of 79% in elite gymnasts compared to 38% in non-athletes.¹⁰⁸ Furthermore, Perich et al (2006) reported a point prevalence of LBP of 47.5% in female adolescent rowers compared to 15.5% in age and gender matched non-rowers.⁸³

2.3.6 Back pain in rowing

An early retrospective review of elite rowers' medical records reported that almost all rowers suffered from 'backache'.¹⁰² This was one of the first studies linking back pain and rowing, however the age of the rowers was not reported.¹⁰² While this study was limited to a small population (n=29) with unclear methods and definition of LBP, it did appear to provide the impetus for increased research into the prevalence of LBP in rowers. Incidence and prevalence rates of LBP in rowers, from amateur to elite, and adolescents to adults, are reported to range from 15.2% to 82.2% (Table 2.2).^{7,15,32,42,48,83,98,106,109,110,120} Most recently, Wilson et al (2010) used a 12-month prospective study on internationally competitive male and female rowers with a mean age of 26.25 and found the highest number of injuries in rowing was reported in the lumbar spine (31.82% of total injuries).¹²⁰ While a large disparity in the reported prevalence of LBP in rowers is evident, it is clear that the problem exists in this population.

The wide discrepancy in reported rates of LBP in rowers is likely due to methodological differences between the studies cited, including different LBP definitions, cohort demographics (age & gender) and experience levels (Table 2.2). For example, while 9 out of 11 studies described in table 2.2 all used questionnaires, there was no consistency in questionnaires between studies, with no validated standard assessment evident. As a

Table 2.1 – The lifetime prevalence of LBP between specific sporting population and no-sports group. (grade, gender and BMI corrected)
(Table adapted from Sato et al., 2011)⁹¹

Type of Sports	Number of participants	LBP (%)	Odds Ratio	95% confidence interval	p-value
Swimming	5,662	27.5%	1.41	1.27-1.55	<0.001
Basketball	3,726	37.9%	1.79	1.61-1.99	<0.001
Soccer	3,534	34.9%	1.77	1.56-2.02	<0.001
Baseball	3,525	37.5%	1.82	1.60-2.06	<0.001
Tennis	2,097	34.3%	1.24	1.09-1.42	<0.01
Table tennis	1,486	34.7%	1.05	0.89-1.21	0.63
Volleyball	1,445	46.6%	2.14	1.86-2.46	<0.001
Athletics	1,324	48.6%	2.18	1.89-2.52	<0.001
Kendo	993	35.5%	1.39	1.18-1.65	<0.001
Karate	897	31.9%	1.57	1.31-1.87	<0.001
Badminton	771	39.8%	1.51	1.26-1.87	<0.001
Ballet	669	30.3%	1.63	1.33-1.99	<0.001
Dance	582	34.7%	1.75	1.42-2.15	<0.001
Judo	569	51.1%	2.12	1.73-2.52	<0.001
Gymnastics	560	36.3%	2.05	1.67-2.51	<0.001
Golf	102	51%	2.2	1.45-3.35	<0.001
Dodgeball	95	32.6%	1.59	0.95-2.55	0.08
Rugby	70	51.4%	2.58	1.56-4.27	<0.001
Wrestling	48	35.4%	0.85	0.42-1.71	0.65
Archery	23	39.1%	1.1	0.42-2.88	0.84
<i>Sports group</i>	21,280 / 26,766	34.9%	1.57	1.45-1.70	<0.001
<i>No sport</i>	5,486 / 26,766	21.3%	1		

result direct comparisons between studies are not possible. However, several rowing specific factors that may influence the reported rate of LBP were highlighted in the studies. For example, the results from three studies confirm that LBP prevalence and incidence rates fluctuate depending on timing of studies relative to the rowing season suggesting that training load may be a factor.^{42,82,109,120} Perich et al (2011) reported that a group of female adolescent rowers (n=131) had a higher incidence of LBP during the middle and end of the rowing season (where training intensity is highest) when compared to the start of the season and at 12-weeks after the final regatta (i.e. a period of no training) (Figure 2.4).⁸² However, this study was limited by the high attrition rate (72%) from the start of the season to post-season data collection. Teitz et al (2002) reported that the off-season was the time of the year associated with the smallest number of USA college rowers reporting LBP.¹⁰⁹ Hickey et al (1997) reported that the highest incidence of LBP were reported in the 3 months prior to competition, a time linked to the largest training volume, in a cohort of elite rowers in Australia.⁴² It is therefore clear that the timing of data collection relative to the rowing season should be considered in order to ensure valid and reliable comparisons.

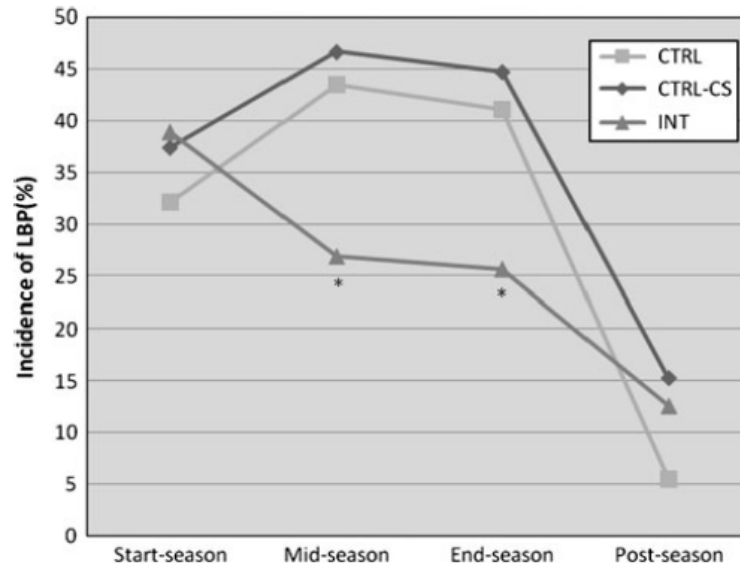

Figure 2.4 – The incidence of LBP in adolescent female rowers during different parts of the rowing season for the intervention group (INT: n=90) and control group (CTRL: n=131). (Figure from Perich et al., 2011)⁸²

Few studies have compared LBP prevalence between rowers and non-rowers from a similar subgroup of the population. One study reported a higher incidence of LBP (82.2%) in a small sample of elite female rowers in the US (n=17) compared to the non-rowing population (25 to 30%).⁴⁸ However, this study was limited by the small sample size (n=17) and the lack of clarity regarding demographics (age of participants is unknown and the two populations were from different locations). Another study compared the prevalence of LBP in adolescent female rowers to their age matched non-rowing school peers. They found that rowers had a significantly higher point prevalence of LBP (47.5%) (n=256) than non-rowers (15.5%) (n=496).⁸³ This study further reported that the higher prevalence in rowers was consistent across each age year (14 to 17) compared to non-rowers.⁸³ Although statistical analysis was not used to compare these prevalence rates, these findings support the supposition that rowing appears to be a specific risk factor for LBP in adolescent females.⁸³

Table 2.2 - Studies of prevalence / incidence of low back pain in rowers (y = years; SD = standard deviation)

Author(s)	Sample	Age	Prevalence / Incidence (%)	Study period	Additional information
Howell (1984) ⁴⁸	17 elite lightweight females (US national rowing team)	Not reported	Incidence 82.2% females	1983	Excessive lumbar flexion correlate with LBP / discomfort
Budgett and Fuller (1989) ¹⁵	69 amateur to elite British rowers	18 – 33y	Incidence 55.6% of rowers with injuries	1986-1987	Occurred significantly more frequently in weight and circuit training than rowing or running
Hickey et al (1997) ⁴²	172 Elite Australian rowers (82 females, 88 male)	14 – 36y	Incidence 25.0% males 15.2% females	1985-1994	Majority of LBP were chronic (24/29 in males and 19/31 in females)
Teitz et al (2002) ¹⁰⁹	1632 (694 females, 936 male, 2 unknown)	Former intercollegiate rowers (20 – 45y)	Prevalence 31.7% males 32.9% females 32% total	1978-1998	Rowing related factors – ergometer rowing, history of rowing before 16 years old Most common developed in winter
Teitz et al (2003) ¹¹⁰	1561	Former intercollegiate rowers (20 - 45y)	Prevalence Lifetime - 51.4%	1978-1998	No different from general population Mean severity of pain 3.5 / 10
Bahr et al (2004) ⁷	199 rowers (131 males, 68 females)	Males (21y, SD 6) Females (22y, SD 5)	Prevalence Lifetime– 63.3% 12 mths - 55.3% 7 days - 25.3	2000	Lifetime prevalence higher than controlled
Stutchfield and Coleman (2006) ¹⁰⁶	26 university rowers	Males (20.6y, SD 1.5)	Prevalence Lifetime – 81% Point – 42%	Not reported	Hamstring flexibility not associated with LBP.
Perich (2006) ⁸³	356 School girls	14 - 17y	Prevalence Point - 47.5%	2005	Age 14 – 52.3%; Age 15 – 39.7%; Age 16 – 46.0%; Age 17 – 54.1%; Age matched controls – 15.5%

Wilson et al (2010) ¹²⁰	20 (12 males, 8 females) Irish international rowers	Mean (26.25y, SD 4.18) years	Incidence 31.82% total	2003-2004	Only prospective study investigating incidence of LBP in rowers Ergometer rowing was significantly associated with injury risk
Smoljanović et al. (2009) ⁹⁸	398 Elite junior rowers (167 females, 231 males – from 45 different countries)	Median (18 y) Inter-quartile range = 1 year (males and females)	Incidence = Total - 32.3% Males – 34.4% Females – 29.9%	2007	LBP most common cause for rowing absence Overuse injuries > traumatic
Foss et al 2012 ³²	173 rowers (112 males, 61 females)	Former rowers Males (32y, SD 6) Females (32 y, SD 5)	Prevalence Lifetime - 68% 12 mths - 57% 7 days - 19%	2000	A 10 year follow up study from Bahr et al (2004) No significant differences with controlled (non athletes)

Given the known effect of strenuous exercises on LBP prevalence between genders,^{18,53} it cannot be assumed that the higher prevalence of LBP in females compared to males in the general population would be the same in rowers. Interestingly, it appears that the opposite may be the case in rowing populations. Two independent studies documented that male rowers have a higher incidence rate of LBP than female rowers.^{42,98} More specifically, Hickey et al (1997) reported that international elite male rowers (aged between 14 to 36 years old) reported a higher incidence of LBP (25%) than females (15.2%) over a 10-year period.⁴² This study used a retrospective analysis of medical records of 172 elite rowers (males: 88 and females: 84) and defined an injury as any episode of pain that was presented to medical practitioners within the department.⁴² However this study did not discriminate between adolescent and adult rowers and statistical analysis was not used to determine whether the gender differences were significant. Smoljanovic (2009) utilized a questionnaire and interview and found that international elite junior male rowers were at greater risk of LBP (34.4%) than females (29.9%) [median age of 18 and an interquartile range of 1 year (males: n=231 and females: n=167)].⁹⁸ This study did not show the LBP prevalence of early adolescent rowers and statistics were not performed to compare gender differences in LBP prevalence. To further compound this problem of higher prevalence of LBP in male, they also appear to be at greater risk of suffering 'chronic' back pain than female rowers.^{42,98} Indeed, two studies confirmed that elite male rowers were more likely to report chronic LBP than females, (24 out of 29 (83%) in males as compared to 19 out of 31 (61%) in females)⁴² (34.8% junior males vs 27.5% junior females).⁹⁸ However, the studies were limited by the lack of a clear definition of chronic LBP, with both studies reporting that chronic (or overuse) injuries are those that were not brought on by a specific event,^{42,98} and statistical analyses were not performed to determine whether differences were significant. These studies suggest that there may be gender specific rowing related factors that contribute to LBP in male and female rowers of all ages. While the prevalence of LBP has been reported in female adolescent rowers, no studies have

investigated the prevalence of LBP for adolescent male rowers. Therefore further study is warranted comparing the prevalence of LBP in adolescent male rowers.

2.3.7 Summary

Prevalence rate of LBP in rowers - Summary

What we know:

- Incidence/prevalence of LBP varied greatly depending on the definition of LBP, time period, genders, age and specific athletic populations.
- Adolescence is a period of increasing LBP prevalence.
- LBP in adolescent is a major risk factor for LBP in adulthood.
- Females report a higher prevalence of LBP in the general population.
- There is increased LBP prevalence in specific sports.
- Female adolescents who row reported higher LBP prevalence than non-rowers.
- Some research suggests that males may be at more risk of LBP in the rowing population.

What we do not know:

- The prevalence of LBP in adolescent male rowers.
- Differences in the prevalence of LBP between adolescent amateur male and female rowers.

2.4 Risk Factors of Low Back Pain in Rowers

2.4.1 Introduction

There has been limited research regarding the potential mechanisms associated with LBP in rowers and in particular adolescent rowers. However research in the wider population has reported a large number of risk factors ranging across the physical, psychological, social and lifestyle domains.¹¹⁷ A number of psychological factors (such as anxiety and depression),^{14,24,60} social factors (such as social status, levels of education and occupation),¹⁴ and lifestyle factors (such as participating in excessive physical activities)⁹ have been linked with LBP and disability in the general population. However, only a small subgroup of adults or adolescents with LBP are associated with psychosocial factors.^{11,43} There is some evidence that psychosocial factors may play a role in elite sporting populations,³³ although little research has been directed towards rowing populations. One study has directly investigated the contribution of psychosocial factors in rowers with LBP and found no differences in psychosocial factors between adolescent rowers with and without LBP.⁸³ In contrast, physical factors were found to differentiate the groups.⁸³ This, coupled with the physical nature of rowing (such as repeated spinal flexion), suggests that physical factors are most likely to be involved with the high rate of LBP in rowers and will therefore be the focus of this review.

2.4.2 Physical Factors

There are a number of inherent rowing specific factors experienced by all rowers that appear to place them at higher risk of LBP than non-rowers. For example, the type and nature of loads (forces) acting on the trunk during rowing.^{46,47,87} However, not all rowers report LBP, suggesting that individual factors may place some rowers at greater risk. These factors include, but are not limited to, the rower's height, deficits in back and lower limb muscle endurance, sitting postures, and motor control impairments related to rowing (kinematics and muscle activity).^{16,19,45,65,70,83,87,89,98,109,121} Finally, there may

be specific factors for LBP in rowers that relate to inherent differences based on gender. Therefore physical risk factors associated with rowing may be broadly grouped into rowing specific risk factors, individual factors and gender specific factors.

2.4.3.1 Rowing specific factors

Mechanics of rowing

There are 2 types of rowing: land based and water based. Water based rowing can further be divided into sculling and sweeping. Scull rowing involves the rowers using two oars while sweep rowing involves the rowers using only using a single oar. As a result there is more trunk rotation associated with sweep rowers.¹⁰⁴ Centre-pulled ergometers (such as a Concept II ergometer) form a large part of both scull and sweep rowers' land-based training routine and performance testing.^{66,98} Although all forms of rowing have been associated with LBP, there is strong support in the literature that time spent on ergometer rowing in particular, is associated with LBP in adolescent and adult rowers.^{81,109,120} Given that ergometer rowing has an association with LBP and it lends itself to laboratory testing, there is a growing body of research investigating the potential mechanisms of LBP in ergometer rowing. Although it should be acknowledged that these results might not be directly applicable to on water rowing at a similar stroke rate and rowing intensity, given that a recent study reported that lumbar spinal flexion increases to a significantly greater degree during ergometer rowing than during on-water scull rowing.¹²¹

The basic sequence of a stroke is made up of two events; the *catch* and the *finish*, that define the beginning and end of two phases the *drive* and *recovery*.^{46,47} The *catch* (Figure 2.5A), is the moment when the knees and trunk are flexed with the elbows almost fully extended. It is also the time in ergometer rowing, of maximum forward reach (when the ergometer chain is shortest) and is the beginning of the *drive* phase. During the *drive* phase the rowers then extend their hips, knees and trunk with maximum force in order to generate power to the oar and therefore contribute to forward boat

movement. The *finish* defines the end of *drive* phase and is characterized by maximal relative extension of the knees, hips and trunk with elbows in peak flexion (when the ergometer chain is longest). (Figure 2.5B) Finally, the *recovery* phase is when the oar has been taken out of the water and the athletes return to the *catch* position.⁴⁷ These two phases are vital to the success of generating boat speed in rowing with the trunk acting as a lever, or part of a kinetic chain, to transfer energy from the lower limbs to the oars.^{47,52,54} The repetitive sequence of a rowing stroke and resultant repetitive spinal loading is thought to be involved in the high incidence of LBP reported by rowers.



Figure 2.5A – Catch position during ergometer rowing;
Figure 2.5B – Finish position during ergometer rowing

Compressive loading

Rowers have been reported to experience relatively high levels of lumbar compressive loads or forces during ergometer rowing.^{46,47,87} This loading is not uniform throughout the stroke, with the peak compressive loads of the lumbar spine occurring at approximately 60% of the drive phase during ergometer rowing and reported to be 7 times and 6.8 times body mass for men and women respectively.^{19,46} This is much greater than during other activities, such as jogging where compression forces in the lumbar region were reported to be between 2.7 and 5.7 times body mass.²¹ Compounding this, rowers generate this large magnitude of lumbar compression while performing large flexion and extension movements. Coupled, flexion with compressive loading has been suggested to be a major risk factor for the development of LBP in rowers.^{46,87} The lumbar spine has been reported to be in flexion for approximately 70% of a stroke cycle,^{46,87} with the peak trunk

flexion of approximately 30° occurring at the catch position during ergometer rowing.⁴⁷

Flexion with compressive loading may result in strain to the soft tissue structures of the lumbar spine such as facet joints, intervertebral discs and ligaments, and potentially lead to LBP.^{2,23,87,94}

Cyclic Compressive Loading

The risk of LBP as a result of flexion compressive loading, is compounded by the high rate of repetition this movement is performed,⁸⁷ with rowers reported to perform up to 1800 rowing cycles during a single training session.¹⁹ In-vitro studies have shown that cyclic loading, within physiological limits with small compressive loads, may increase vulnerability to intervertebral disc injuries.^{20,62,100} Although in-vitro studies are not representative of functioning musculoskeletal systems, the risk of cyclical loading is supported by the higher incidence of disc herniation and spondylolytic changes (indicative of stress reaction on the bone) in the lumbar spine of rowers when compared to non-rowers,^{61,99} although it should be noted that these pathological findings are not always associated with pain.⁹⁹ It has also been suggested that the cyclic motion can reduce trunk extensor muscle activation due to the flexion relaxation response.^{28,77,100} This is also associated with increased trunk range of movement due to viscoelastic creep, and a reduction in intervertebral disc height, which may compromise spinal stability and increase risk of LBP.^{28,77,100} The risk of LBP may be increased during rowing through a combination of cyclic flexion and extension compressive loading that compromises the integrity of lumbar soft tissue and bony structures.

Overloading

There is a general consensus in the literature that overloading (high volume of training) is a risk factor for LBP noted in rowers as represented by differences in reported LBP prevalence during the training season.^{42,82,109}

Wilson et al (2010) conducted a 12-month prospective study which reported a significant correlation between increased training time in both ergometer

rowing and heavy weights with high injury rates.¹²⁰ In elite athletes, it is generally accepted that repetitive overload may be related to LBP,⁷ however given that this is also necessary for enhanced performance it is rarely a mechanism the athlete or coach is willing to modify.

2.4.3.2 Individual Factors of LBP in rowers

Despite the compelling evidence that there are inherent aspects of rowing that place all participants at risk of LBP, not every rower reports LBP.

Therefore, it is recognised that individual factors play an important role in the development of LBP. Some research has been performed aiming to identify these factors, with height, muscle endurance, spinal posture, and motor control of the spine during rowing (such as spinal kinematics and muscle activity patterns) all previously linked with LBP in rowers.^{70,83,89}

Height

There is some evidence to support that taller rowers are more at risk of developing LBP.^{98,109} It was suggested that a greater torso length may increase leverage and improve performance, although the increased load to the spine places it at risk of strain.¹⁰⁹ However, the torso length was not specifically measured in this study. Rowers' height is a factor that needs consideration given its relationship with LBP, however it is a variable that cannot be modified.

Hamstring flexibility

It has been proposed that short hamstring length may be a risk factor for LBP in rowers. Reid and McNair (2000) suggested that rowers with short hamstrings may compensate by over flexing the spine to achieve the catch position due to a reduction in anterior rotation of the pelvis.⁸⁷ This is supported by Smoljanovic et al (2009), who reported that elite junior male and female rowers (n=398) who performed 10 minutes of stretching after training reported fewer incidences of acute injuries.⁹⁸ However, this study did not specify the muscle group that was stretched and injuries were not localised to the lumbar region. In contrast, Sutchfield and Coleman (2006)

reported no difference in hamstring flexibility between rowers with LBP (n=11) and no-LBP (n=15) using a straight leg raise test in adult male rowers.¹⁰⁶ In fact, Howell (1984) reported that elite lightweight female rowers (of unknown age) who performed regular hamstring stretches had a higher incidence of LBP. However, this study was limited by a very small population size, and an uneven comparison between 13 rowers that stretched (all reported LBP) compared to 4 rowers (1 reported LBP) that did not stretch. In addition, no details of the hamstring stretch were outlined, of note the rowers independently defined their frequency of stretching as 'regular' without guidance from the researcher.⁴⁸ Further research is required to determine the role of hamstring flexibility in LBP in rowers, as hamstring stretching has often been used as part of an intervention for LBP in this population.^{82,112}

End of range flexion loading

It has been proposed that the position of the lumbar spine relative to the end of range, where the passive structures of the spine are close to being maximally loaded or stretched, may increase the risk of tissue strain and pain.^{1,3,78,79} There is evidence that some rowers flex their lumbar spine near or exceed their end of flexion range during ergometer rowing.^{19,121} Caldwell et al (2003) reported that peak flexion of the lumbar spine in adolescent male and female rowers was between 74-89% of their full range of flexion during the first 50-60% of the drive phase. The study also reported that the peak flexion increased from 75% to 90% of the maximum range of motion over a 2000m-ergometer race.¹⁹ Wilson et al (2013) reported an increase of 5.3° or 11.3% of mid-lumbar flexion (between L2 – L4) from the peak standing flexion angle test and the last step of a physiological rowing ergometer 'step-test', indicating that some rowers may row beyond their full range of lumbar flexion during ergometer rowing.¹²¹ While no study has formally linked end of flexion range strain in rowing with LBP incidence, the relationship has been reported in other sporting populations. For example cyclists with LBP were observed to position their lower lumbar spine nearer to end of range flexion compared to cyclists with no-LBP during prolonged cycling (figure 2.6A and 2.6B).¹¹⁵ Given the relationship linking this near end of range flexion loading

and LBP in cyclists and the evidence that some rowers also approach end of range flexion, further investigation is warranted to examine the association between end of range flexion and LBP in rowers.

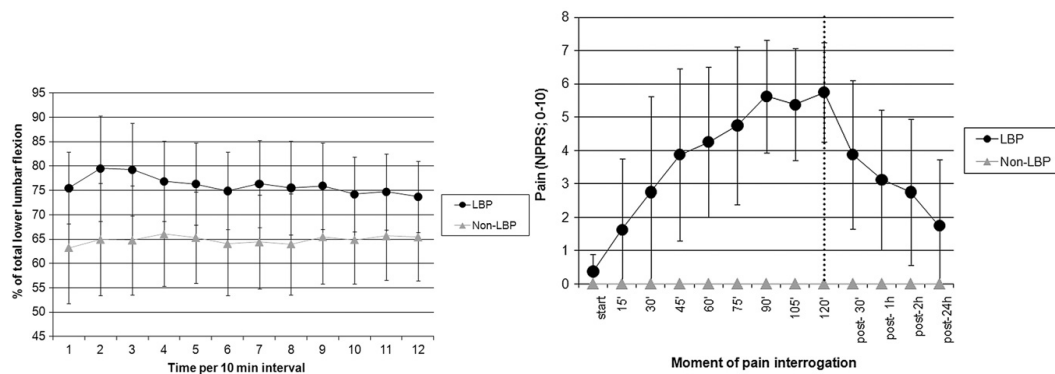

Figure 2.6A – Lower lumbar kinematics (% of full range flexion) of cyclists with LBP and with no-LBP over a 120-minute cycling task. **Figure 2.6B** Average pain score (as measured by the Numeric Pain Rating Scale) of cyclists with pain during a 2-hour cycling task. (Figure from Van Hoof et al., 2012)¹¹⁵

Back muscle endurance (BME)

There is evidence to support that poor BME is associated with LBP in both adult and adolescent rowers.^{19,83,89} Roy et al (1990) were able to correctly identify male rowers with LBP using electromyography (EMG) data obtained during an isometric test in standing, which noted an increased rate of fatigue in back extensor muscles (reduced BME).⁸⁹ Perich et al (2006) also reported that rowers with LBP had poorer BME than rowers with no-LBP in a cohort of adolescent female rowers using an isometric back extensor test (Biering-Sorensen's test).⁸³ Possible causes for reduced BME have previously reported to include slouch (slumped) sitting, low levels of physical activity, increased time watching TV (sedentary behaviours), lower self efficacy and higher body mass index (BMI).^{34,97} While the direct mechanism of this relationship is unclear, poor BME has been associated with increased peak lumbar flexion during a maximal ergometer trial, in healthy rowers.¹⁹ It has been suggested that earlier fatigue of the back extensors leads to reduced lumbar spine flexion control during ergometer rowing, in turn leading to increased risk of end range strain.¹⁹ Goel et al (1993) used a biomechanical model to show that back muscles may act to reduce loading on the vertebral body and reduce intradiscal pressure.³⁶ Therefore, it could be hypothesised that poor BME could lead to increased loading on the spinal structures once

the muscles are fatigued, and the increased loading may lead to LBP. Given its relationship with LBP, BME should be considered in intervention studies in rowers.

Lower limb muscle endurance (LLME)

Poor LLME has been reported as a risk factor for LBP in both adult and adolescent general populations.^{6,12,103} There is also some evidence to support that adolescent female rowers with LBP have poorer LLME compared to rowers with no-LBP.⁸³ While the mechanism for this relationship has not been comprehensively investigated to date, it might be similar to industrial workers performing repetitive lifting tasks where poor LLME is a known risk factor for LBP.¹⁰³ Early quadriceps fatigue has been shown to increase lumbar flexion during lifting.^{101,113} The mechanism may be similar in rowing, given that the lower limb muscles are critical throughout the drive phase of a rowing stroke. Further exploration of the relationship between LLME and the resultant impact on rowing technique and spinal kinematics is required. To date no studies have investigated the effect of improving LLME on reducing LBP in adolescent male rowers.

Sitting Postures

There is debate around the role that spinal posture plays in LBP,^{57,88} however there is evidence that spinal posture is associated with LBP sub-groups.^{6,26,76,83,92,97} Perich et al (2011) identified that adolescent female rowers that slouched in usual sitting (i.e. sat with greater posterior pelvic tilt) had a higher incidence of LBP than age and gender matched rowers with no-LBP.⁸³ This finding has been supported by research in both the general adult and adolescent populations.^{6,26,72,73,96} Slouched sitting posture has been suggested to be a risk factor for LBP for three main reasons. Firstly, slouching positions the lumbar spine closer to end range flexion which may increase strain on spinal structures, which as previously mentioned has been linked with LBP.^{1,3,78} Secondly, habitual slouched sitting is predictive of increased lumbar flexion during bending and lifting.^{69,118} This suggests that spinal kinematics in habitual sitting may translate to functional tasks.^{69,118}

Finally, slouched sitting has been linked to reduced muscle activity in the back muscles and is associated with poorer BME.^{25,97} Cumulatively, these factors may lead to an increase in susceptibility of the lumbar spine to flexion strain when placed under load.

Spinal kinematics of the trunk during rowing

Differences in lumbar kinematics between rowers with and without a history of LBP have also been documented.⁷⁰ O'Sullivan et al (2003) found that 9 nationally and internationally competitive rowers with a history of LBP were more likely to have higher variability in forward motion of their lumbar spine during ergometer rowing.⁷⁰ However, this study lacked information about methodology and demographics with the age of the population not reported, sample size not justified, measures poorly outlined and LBP not defined. Therefore, whilst it has been suggested that lumbar kinematics differ between rowers with and without a history of LBP, further research is warranted, and in particular in rowers with a current complaint of LBP. Most critically, regional lumbar kinematics were not investigated in this study, which has been demonstrated to be necessary in understanding the possible mechanisms of LBP.

There is growing evidence that the lumbar spine cannot be considered as one functional segment. Rather that the upper and lower lumbar spine have demonstrated functional independence as evidenced in a range of studies investigating both sporting and non-sporting populations.^{26,35,69,71} These studies have identified differences in both static postures such as sitting^{26,69} as well as during dynamic tasks such as sit to stand,⁸⁰ bending and lifting⁶⁹ as well as sporting tasks such as gymnastics¹¹⁸ and cycling.¹⁷ These findings support that investigations of the lumbar spine should consider regional differences.

There is growing evidence that the lumbar spine cannot be considered as one functional segment. Rather that the upper and lower lumbar spine have demonstrated functional independence as evidenced in a range of studies investigating both sporting and non-sporting populations.^{26,35,69,71} These

studies have identified differences in both static postures such as sitting^{26,69} and dynamic tasks such as sit to stand,⁸⁰ bending and lifting⁶⁹ as well as sporting tasks such as gymnastics¹¹⁸ and cycling.¹⁷ These findings support that investigations of the lumbar spine should consider regional differences.

A number of studies have investigated lumbar kinematics in healthy rowing populations (Table 2.3). These researchers have reported an increase in lumbar flexion angle during ergometer rowing and suggested that this could increase the likelihood of LBP, although this was not formally investigated.^{16,19,45,65,121} Pollock et al. (2012) reported that some elite female rowers demonstrated an increase in trunk flexion (from C7 to S1) of 10° from the 250m mark to the 1500m mark of a 2000m-ergometer trial.⁸⁶ Holt et al (2003) reported that lumbar flexion (T12 to S1) increased by 1.6° over a 1-hour prolonged ergometer trial in a group of elite male rowers with a mean age of 22.4.⁴⁵ Wilson et al (2013) reported that elite male rowers demonstrated a gradual increase in their lumbar flexion (L2-L4) during a physiological ergometer rowing 'step test'.¹²¹ Pollock et al (2012) suggested that elite rowers had a better ability to sustain lumbar flexion angles during rowing.⁸⁶ While these studies provide evidence that lumbar flexion increases over time during ergometer rowing, the influence of this on LBP remains unknown, as all of the previous studies utilised pain free populations. Furthermore, all the previous studies consider the lumbar spine as a single segment, so the contribution of upper and lower lumbar segments to increasing lumbar flexion has not been examined. Further investigation is required to ascertain if there is a relationship between increasing lumbar flexion and LBP, and whether this relationship is influenced by regional lumbar kinematics.

Table 2.3 presents a summary of studies that have investigated spinal kinematics in rowers. The studies that have investigated lumbar kinematics in rowers have utilised different methodologies. These include electromagnetic motion analysis, video motion analysis, high-resolution video, electrogoniometer and magnetic resonance imaging (MRI), with electromagnetic motion analysis systems appearing to be most common.

Although this is a popular choice of data collection, its validity has only been investigated in static positions.¹⁶ Bull and McGregor (2000) reported an error of 1° (SD 1°, n=6) between the sagittal angles of the electromagnetic motion sensors attached on the skin and the sagittal angles of the vertebrae at the catch and finish positions as measured on MRI.¹⁶ However, this study is limited by the small sample size and it also did not identify the potential issue of interference caused by the ferrous material of the rowing ergometer during dynamic testing. Electromagnetic motion analysis systems appear to be a good option to determine regional lumbar kinematics during ergometer rowing, however further research is needed to establish the validity of the system.

Table 2.3 – Summary of spinal kinematics research in rowers

Authors	Population	Method of Collection	Significant Findings	Relevance
Bull and McGregor (2000) ¹⁶	National level healthy male aged 20-21 years old (n=6)	Flock of Birds (electromagnetic motion analysis system) and MRI 10 minutes fatigue protocol	Differences in spinal kinematics between 'good' and 'bad' rowing styles	There is 'good' rowing technique Possible dynamic feedback systems
McGregor et al (2002) ⁶³	20 elite male rowers (mean age 22.6) 9 with previous history of LBP, 4 with current LBP	MRI – with a wooden rowing jig. Scan of 4 key stages of rowing	Rowers with current or previous history of LBP had reduced lumbar mobility, but greater pelvic rotation and some abnormal MRI findings	Marked differences in intersegmental motion between rowers with no-LBP, history of LBP and current LBP
O'Sullivan et al (2003) ⁷⁰	18 national and international rowers (age unknown, 9 rowers LBP previously, 9 healthy)	Flock of Birds (electromagnetic motion analysis system). Force data at the handle of the ergometer	Rowers with LBP had sharp rise in forces at the catch. Variability in the spinal motion and stroke length	A possible way to discriminate rowers with and without LBP.
Caldwell et al (2003) ¹⁹	16 healthy (8 males and 8 females) school rowers training for national regattas (mean age 16.4)	Retro-reflective motion analysis system, EMG, 2000m race protocol	Increased lumbar flexion during trial, increase activation of back extensors	Excessive lumbar flexion and fatigue may have potential for injury
Holt et al (2003) ⁴⁵	13 elite national and international male rowers (mean age 22.4) 6 with previous history of LBP and 7 no-LBP	Flock of Birds, 60 min ergometer session, 18-20 strokes per minute, heart rate at 130-150 bpm	Marked increases in the amount of spinal motion during a 1-hour of ergometer rowing	Further research to link increase spinal movement with LBP
McGregor et al (2004) ⁶⁴	10 college male rowers (mean age 22.1)	Flock of Birds with load cell, 3 stroke rating	Increases in force output. Less anterior pelvic rotation at catch position at higher rowing rates.	Increase rowing intensity and changes in kinematics associated with increase intensity may have injury implications
McGregor et al (2007) ⁶⁶	National level healthy females (mean age 25.6) (n=7)	Flock of Birds, a 'step' test based on best 2000m ergometer time. 2 year follow up	Changes in temporal and spatial spinal kinematics over 2 years, with increase peak force output	Rowing techniques change over time

McGregor et al (2008) ⁶⁷	Heavy weight national level 13 female rowers (mean age 27.2) and 10 male rowers (mean age 24.3)	Flock of Birds with load cell, 3 x 300m with different intensity based on personal best time	Males demonstrated greater peak force, females greater anterior pelvic rotation	Kinematics and kinetics differences between adult male and female rowers
Mackenzie et al (2008) ⁵⁸	6 elite male rowers (mean age 21.7) 2 reported previous back problems	Flock of Birds with load cell, 60 min ergometer session, 18-20 strokes per minute, heart rate at 130-150 bpm	No significant changes in thigh flexion/extension, pelvic rotation, lumbar rotation, lumbo-pelvic ratio	Low intensity training does not change techniques in elite rowers
Pollock (2009) ⁸⁵	9 national competitive female rowers, 3 with past history of LBP (mean age 25.8)	Eagle HiRes Cameras (optical motion capture system), EMG, 2000m race simulation. Comparison between kinematics and kinetics during peak force production	Minimal coactivation of flexors and extensors. Most extension occurs at the pelvis.	Minimal coactivation of trunk flexor and extensor muscles, and minimal movement at L3-S1 shows most movement, may have association with LBP.
Strahan et al (2011) ¹⁰⁴	5 males and 5 females high-level rowing with no-LBP in past 3 months (mean age 19.1)	3-Space Fastrack System (electromagnetic motion analysis system) with total and regional spinopelvic kinematics – row on modified sweep and scull ergometers	Sweep ergometer rowing associated with greater lateral bend in upper lumbar and lower thoracic region and greater rotation at the pelvis.	Differences exists between sweep and scull ergometer rowing in spinopelvic kinematics. No differences in lower lumbar may be a protective response
Wilson and Gormley (2011) ¹²²	19 elite male rowers (mean age 24.2)	Twin axis electrogoniometer, fatiguing protocol, incremental 'step test' on ergometer and on sculling boat	Lumbar flexion increased greater on ergometer rowing compared to boat rowing	Greater sagittal motion in the lumbar spine during ergometer rowing than on-water rowing
Pollock (2012) ⁸⁶	9 national competitive female rowers, 3 with past history of LBP (mean age 25.8)	Eagle HiRes Cameras (optical motion capture system), EMG, 2000m race simulation. Comparison of kinematics and kinetics at 1500m with at 200m	Delayed peak extension angular velocity at T4-T7 & L3-S1 in early drive and T10-L1 and L1-L3 in late drive at 1500m compared to 200m. Increase abdominal activity at 1500m at 1500m	The trunk acts as a stiff lever to transfer forces. Increased abdominal activity late in the rowing piece may reflect increased demand to control trunk over time.
Wilson et al (2013) ¹²¹	19 healthy elite male rowers (mean age 23.17)	Spectrotilt RS232 electronic inclinometer, incremental 'step test' on ergometer	Increase in angular displacement at L3 over the course of the test	Lumbar spine flexion increases significantly during ergometer rowing ($+4.4^{\circ} \pm 0.9^{\circ}$), whereas minimal changes during scull rowing ($+1.3^{\circ} \pm 1.1^{\circ}$ change)

2.4.3.3 Gender specific risk factors

Risk factors for LBP in rowing may be different between genders. Males and females are known to differ in a range of physical attributes relevant to rowing and related LBP including; rowing performance, strength, BME, sitting posture and LBP prevalence.^{51,59,68,97,107,123} More specifically, males are known to have a smaller proportion and smaller relative size of slow twitch muscle fibres (Type I fibres) and a greater proportion of fast twitch fibres (Type IIa and Type IIb fibres) than females in the back extensors and quadriceps muscles.^{59,68} This is reflected in females having better BME than males.^{51,97,107} Males have also been reported to sit with more posterior pelvic tilt, and have their trunk in more flexion than females in both adult³⁰ and adolescent age groups.^{97,105} Given that both reduced BME and sitting in increased flexion have been linked with LBP, this may account for male rowers having a higher prevalence of LBP than their female counterparts.

The differences in muscle characteristics and sitting postures may also lead to differences in regional lumbar spine kinematics between male and female rowers. Only one study has compared differences in kinematics of the spine between adult male and female rowers.⁶⁷ This study compared the hip, pelvic and lumbar kinematics of 23 nationally competitive adult heavyweight rowers (13 females and 10 males) and found that females rowed with greater anterior pelvic rotation and thigh flexion at the catch position compared to males.⁶⁷ This was suggested to be indicative of a more optimal rowing position to compensate for weaker peak forces and less power generated by the females compared with the males.⁶⁷ Less anterior pelvic tilt (or greater posterior tilt) is associated with greater trunk flexion in sitting in males.³⁰ It is hypothesised that less anterior tilt during rowing may also lead to greater flexion loading or end range flexion loading in male rowers. This increase in trunk flexion was represented by a greater lumbo-pelvic ratio at the catch position in male rowers compared to female rowers.⁶⁷ However this study was limited by not comparing the regional lumbar kinematics and the relative position of these regions to end of flexion range. Future studies should investigate regional lumbar kinematics between

males and females relative to end of range flexion. This will indicate if investigations regarding LBP mechanisms should be gender specific.

2.4.4 Summary

Factors associated with LBP in adolescent rowers - Summary

What we know:

- Physical risk factors are likely to be dominant for LBP in rowers.
- Rowing specific factors such as compressive loading, cyclic loading, end range spinal flexion loading and overloading may be risk factors for LBP in rowers.
- Individual factors such as rowers' height, poor BME and LLME, slouched sitting posture and lumbar kinematics in relation to end of range flexion during rowing may be risk factors for LBP.
- Males have poorer muscle endurance and more slouched sitting posture, which may be associated with greater degree of end range flexion loading during rowing placing male rowers at more risk of LBP than females.

What we do not know:

- The validity and reliability of using electromagnetic devices to measure regional spinal kinematics dynamically.
- Whether adolescent male and female rowers demonstrate different pelvis, regional lumbar and thoracic kinematics during rowing.
- The relationship between ergometer rowing and LBP during ergometer rowing.
- Whether there are differences in regional lumbar kinematics between rowers with LBP at the time of testing compared to rowers with no-LBP.

2.5 Management of Low Back Pain in Rowers

2.5.1 Introduction

This review has demonstrated that rowers, in particular adolescent rowers, are at significant risk of developing LBP.⁸³ Given that LBP during adolescence is a known predictor of LBP in adulthood,^{10,13,41,50} investigating the prevention and management of LBP should be the focus of future research to enable safe and ongoing participation in the sport. A number of treatment regimes to manage LBP disorders in the general population have been researched and published in the literature. However, very few interventions have been shown to be superior to other treatments when rigorously analysed through research processes such as with randomised controlled trials or meta-analyses.^{5,31,39} Currently, there are only two studies that have explored the outcomes of specific LBP interventions on rowers.

2.5.2 Cognitive functional therapy for Management of LBP in rowers

The two prospective intervention studies have both reported efficacy with targeted cognitive functional intervention programs that address physical, cognitive and lifestyle domains for the management of adolescent female rowers with LBP.^{82,112} Perich et al (2011) performed a non-randomised study on 333 adolescent female rowers aged 14-17.⁸² Ninety-five rowers from one school received a targeted cognitive functional therapy (CFT) intervention that consisted of a group education session and between 3-6 individualised physiotherapy assessment and treatment sessions. Details of the treatment are displayed in table 2.4 and figure 2.7. Two hundred and thirty-eight participants from 3 other schools were allocated in the non-intervention group, where they received their usual level of care from their coaches.⁸² Following the intervention period, the intervention group reported a reduction in point prevalence of LBP and a reduction in pain intensity and disability in the intervention group compared to the non-intervention group (Figure 2.4).⁸² Further, the secondary outcomes of the study showed that the intervention

group reported an improvement in LLME, BME, 12-minute run, lumbo-pelvic flexibility and had a more upright sitting posture (away from end of range flexion). The results of this study support the proposition that an intervention that targets multiple domains is effective in reducing LBP in adolescent female rowers. There are several limitations to this study, firstly the subject grouping was not randomised or blinded which led to uneven group sizes. There was also a high rate of attrition between the start of the season and post-season questionnaire. Further, the rowers between groups were from different schools, and were subjected to different coaching and rowing training (workload and rowing techniques). Physical measurements such as BME, LLME, physical fitness, flexibility and sitting postures were not taken in the non-intervention group, hence no comparisons between groups could be made. Therefore the improvements detected between pre-season and end of season in physical variables could be a result of rowing training and competition, and not necessarily correlated to the intervention. Due to the range of factors targeted by the intervention and corresponding outcome variables, the authors could not conclude the exact elements, which could correlate directly with the treatment outcome.

Table 2.4 Details of the targeted cognitive functional approach for Management of LBP in rowers
(Adapted from Perich et al., 2011).⁸²

Component	When (duration)	Details of Intervention
Initial Musculoskeletal Screening	Week 1	<p>Interview to assess current and previous history of LBP, pain location, aggravating and easing factors for LBP, as well as treatment history, attitudes towards LBP, current levels of rowing training and general activity.</p> <p>Physical examination to examine spinal range of movement, directional pain provocation, habitual spinal postures in sitting and standing and lumbo-pelvic motor control</p> <p>Lumbo-pelvic motor control was assessed by the ability to maintain neutral lumbar spine with relaxed thorax during sitting while performing hip flexion and knee extension, sitting bending with forward reach, sit to stand, squat with forward reach, seated row position on a rowing ergometer)</p>
Individual-specific exercises conducted by participants with and without LBP (as a result of the initial musculoskeletal screening)	Throughout the season and performed daily (daily for approximately 10 minutes)	For participants with LBP, exercises were designed to address specific deficits in lumbo-pelvic motor control, based on motor control impairments identified on examination as being pain provocative. ⁷⁴ (Figure 2.7) For participants without LBP, each programme addressed motor control deficits which were recognized as having the potential to cause LBP in the subject. ⁷⁴
Back management education	Week 2 (2 hours)	Education on basic spinal mechanics, injury risk, mechanisms for LBP, spinal posture whilst sitting, rowing and lifting, and attitudes and coping strategies with regard to the management of LBP. Coaches parents and physical education staff were encouraged to attend.
Follow-up musculoskeletal screening sessions	Week 3 (7-15 minutes)	These sessions allowed the physiotherapists to provide feedback on how the exercises were performed and to assess progress. There was a minimum of two follow-up sessions with some rowers requiring five follow-up sessions
Off-water-conditioning programme (integrated into the training programme of the rowers)	Week 3 -23 (1.5h/week in weeks 3-12 and 1 h/week in weeks 13-21)	Component was specifically designed to increase lower limb and back muscle endurance and improve aerobic capacity. The training programme consisted of aerobic conditioning, hill running, fitness circuits, strength and conditioning circuits and flexibility training. Time was also allocated in each session for rowers to complete their exercise programmes by the physiotherapist.



Figure 2.7 Rowing exercises in the physiotherapy intervention program. (Figure from Thorpe et al., 2009)¹¹²

A subsequent field study, published earlier, also performed a non-randomised clinical trial on 82 adolescent female rowers aged between 13-17.¹¹² Grouping was also based on the participant's choice to undergo intervention. In contrast to the study by Perich et al (2011), both intervention and non-intervention groups were from a single school, and both groups attended a 1-hour education session with their parents or guardian and the rowing coaches similar to the education session outlined by Perich et al (2011)(Table 2.4).¹¹² Following this, the intervention group underwent musculoskeletal screening and physical examination by 8 experienced musculoskeletal or sports physiotherapists as outlined by Perich et al (2011)(Table 2.4)(Figure 2.7). The participants in the intervention group all received a total of 3 physiotherapy sessions (initial musculoskeletal screening, followed by 2 sessions on week-1 and week-3).¹¹² The results of the study showed a significant reduction in point prevalence of LBP in the intervention group (n=36) compared to the non-intervention (n=46) group from the pre-season to mid-season (figure 2.8).¹¹² The reduction in prevalence in the intervention group was also associated with a significant improvement in self-reported level of pain as measured by the VAS and disability as measured by the modified Oswestry questionnaire.¹¹² Further, a significant improvement in lower limb flexibility and LLME was reported between pre-season and end of season.¹¹¹ A strength of this study was that the coaching and education were controlled between both groups. Therefore, the outcomes of reduced prevalence of LBP and improvement in reported pain in the intervention group was more likely to be related to physical factors targeted by treatment. However, due to the subject grouping not being randomised or blinded, there were uneven group sizes with more rowers with LBP electing to have intervention leading to differing baseline point prevalence. The fact that it was based on individual selection also brings in the confounding factor of motivation with self-selection bias. This may have contributed to a more positive result in the intervention group.

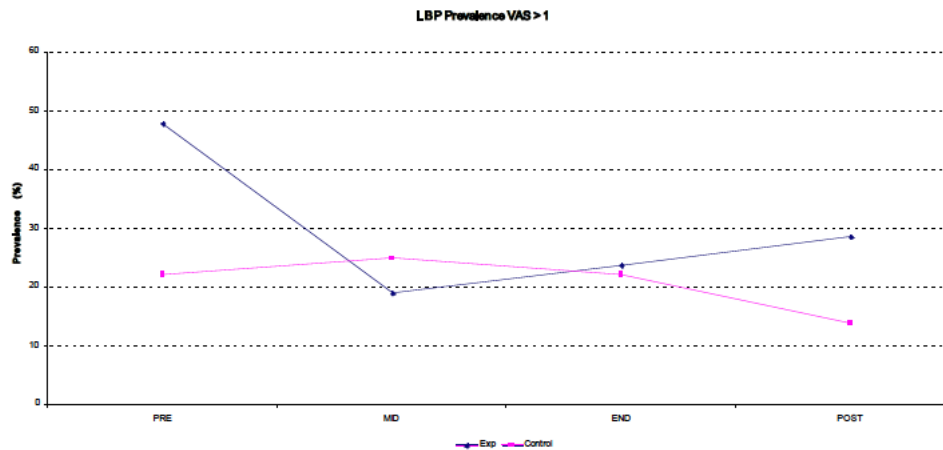

Figure 2.8 Point prevalence of LBP between intervention and no-intervention group during the rowing season. (Figure from Thorpe et al., 2009)¹¹²

In summary, both CFT intervention studies demonstrated positive LBP outcomes for the treatment groups. However neither study reported the treatment fidelity of the rowers in the intervention group, which clearly affects the significance of this main finding. Further, changing lumbar kinematics during ergometer rowing was targeted as part of the CFT intervention but was not an outcome measure in both studies, despite several studies suggesting that this is a potential risk factor for LBP in this athletic population indicating that it should be explored further.^{16,19,45,65,86,122} Finally, both studies were specific to adolescent female amateur rowers. Given the recognised differences between genders, in particular as they relate to rowing and LBP, treatment that previously has proven to be successful in adolescent females may not be effective in adolescent males. Therefore, the efficacy of a multidimensional approach to treatment of LBP in adolescent male rowers should be investigated using a randomised control trial. A study that measures the known key risk factors and outcome measures will be able to assist with furthering the development of a targeted treatment for this high-risk group.

2.5.6 Summary

Physiotherapy Intervention - Summary

What we know:

- Only 2 clinical trials have been conducted on the treatment of LBP in rowers.
- Two non-randomised trials utilizing CFT as the form of intervention have been demonstrated to effectively reduce the prevalence of LBP, pain intensity and disability in adolescent female rowers with LBP.
 - Studies that utilized CFT to reduce LBP in rowers are limited by self-selection bias, lack of randomization and blinding and lack of comparable outcome measures in the control group.

What we do not know:

- There have been no randomized controlled trials on any intervention for LBP management in rowers.
- It is not known whether CFT is effective in the management of LBP in adolescent male rowers.
- It is not known whether CFT can change regional lumbar kinematics during ergometer rowing.

2.6 References

1. Adams M, Hutton W, Stott J. The resistance to flexion of the lumbar intervertebral joint. *Spine*. 1980;5(3):245-253.
2. Adams MA, Dolan P. Recent advances in lumbar spinal mechanics and their clinical significance. *Clinical Biomechanics*. 1995;10(1):3-19.
3. Adams MA, McMillan DW, Green TP, Dolan P. Sustained loading generates stress concentrations in lumbar intervertebral discs. *Spine*. 1996;21(4):434-438.
4. Airaksinen O, Brox JI, Cedraschi C, Hildebrandt J, Klüber-Moffett J, Kovacs F, et al. Chapter 4. European guidelines for the management of chronic nonspecific low back pain. *European Spine Journal*. 2006;15 Suppl 2:S192-300.
5. Assendelft WJ, Morton SC, Yu EI, Suttorp MJ, Shekelle PG. Spinal manipulative therapy for low back pain. *Cochrane Database of Systematic Reviews*. 2004(1):CD000447.
6. Astfalck RG, O'Sullivan PB, Straker LM, Smith AJ. A detailed characterisation of pain, disability, physical and psychological features of a small group of adolescents with non-specific chronic low back pain. *Manual Therapy*. 2010;15(3):240-247.
7. Bahr R, Andersen SO, Loken S, Fossan B, Hansen T, Holme I. Low back pain among endurance athletes with and without specific back loading--a cross-sectional survey of cross-country skiers, rowers, orienteers, and nonathletic controls. *Spine*. 2004;29(4):449-454.
8. Balague F, Dutoit G, Waldburger M. Low back pain in schoolchildren. An epidemiological study. *Scandinavian Journal of Rehabilitation Medicine*. 1988;20(4):175-179.
9. Balague F, Mannion AF, Pellise F, Cedraschi C. Non-specific low back pain. *Lancet*. 2012;379(9814):482-491.
10. Balague F, Troussier B, Salminen JJ. Non-specific low back pain in children and adolescents: risk factors. *European Spine Journal*. 1999;8(6):429-438.
11. Beales DJ, Smith AJ, O'Sullivan PB, Straker LM. Low back pain and comorbidity clusters at 17 years of age: a cross-sectional examination

- of health-related quality of life and specific low back pain impacts. *The Journal of Adolescent Health*. 2012;50(5):509-516.
12. Bernard JC, Bard R, Pujol A, Combey A, Boussard D, Begue C, et al. Muscle assessment in healthy teenagers, Comparison with teenagers with low back pain. *Annales de Readaptation et de Medecine Physique*. 2008;51(4):263-283.
 13. Brattberg G. Do pain problems in young school children persist into early adulthood? A 13-year follow-up. *European Journal of Pain*. 2004;8(3):187-199.
 14. Buchbinder R, Jolley D. Effects of a media campaign on back beliefs is sustained 3 years after its cessation. *Spine*. 2005;30(11):1323-1330.
 15. Budgett RG, Fuller GN. Illness and injury in international oarsmen. *Clinical Sports Medicine*. 1989;7:49-52.
 16. Bull AMJ, McGregor AH. Measuring spinal motion in rowers: the use of an electromagnetic device. *Clinical Biomechanics*. 2000;15(10):772-776.
 17. Burnett AF, Cornelius MW, Dankaerts W, O'Sullivan PB. Spinal kinematics and trunk muscle activity in cyclists: a comparison between healthy controls and non-specific chronic low back pain subjects - a pilot investigation. *Manual Therapy*. 2004;9(4):211-219.
 18. Burton AK, Clarke RD, McClune TD, Tillotson KM. The natural history of low back pain in adolescents. *Spine*. 1996;21(20):2323-2328.
 19. Caldwell JS, McNair PJ, Williams M. The effects of repetitive motion on lumbar flexion and erector spinae muscle activity in rowers. *Clinical Biomechanics*. 2003;18(8):704-711.
 20. Callaghan JP, McGill SM. Intervertebral disc herniation: studies on a porcine model exposed to highly repetitive flexion/extension motion with compressive force. *Clinical Biomechanics*. 2001;16(1):28-37.
 21. Cappozzo A, Bernie N. Loads on the lumbar spine during running. In: Winter DA, Norman RW, Wells RP, Hayes KC, Patla AE, eds. *Biomechanics IX-B*. Champaign, IL: Human Kinetics Publisher; 1985:97-100.

22. Cassidy JD, Carroll LJ, Cote P. The Saskatchewan health and back pain survey. The prevalence of low back pain and related disability in Saskatchewan adults. *Spine*. 1998;23(17):1860-1867.
23. Cholewicki J, McGill SM. Mechanical stability of the in vivo lumbar spine: implications for injury and chronic low back pain. *Clinical Biomechanics*. 1996;11(1):1-15.
24. Croft PR, Papageorgiou AC, Ferry S, Thomas E, Jayson MI, Silman AJ. Psychologic distress and low back pain. Evidence from a prospective study in the general population. *Spine*. 1995;20(24):2731-2737.
25. Dankaerts W, O'Sullivan P, Burnett A, Straker L. Altered patterns of superficial trunk muscle activation during sitting in non-specific chronic low back pain patients: importance of sub-classification. *Spine*. 2006;31(17):2017-2023.
26. Dankaerts W, O'Sullivan P, Burnett A, Straker L. Differences in sitting postures are associated with nonspecific chronic low back pain disorders when patients are subclassified. *Spine*. 2006;31(6):698-704.
27. Dionne CE, Dunn KM, Croft PR, Nachemson AL, Buchbinder R, Walker BF, et al. A consensus approach toward the standardization of back pain definitions for use in prevalence studies. *Spine*. 2008;33(1):95-103.
28. Dolan P, Adams MA. Repetitive lifting tasks fatigue the back muscles and increase the bending moment acting on the lumbar spine. *Journal of Biomechanics*. 1998;31(8):713-721.
29. Duggleby T, Kumar S. Epidemiology of juvenile low back pain: a review. *Disability and Rehabilitation*. 1997;19(12):505-512.
30. Dunk NM, Callaghan JP. Gender-based differences in postural responses to seated exposures. *Clinical Biomechanics*. 2005;20(10):1101-1110.
31. Ferreira ML, Ferreira PH, Latimer J, Herbert RD, Hodges PW, Jennings MD, et al. Comparison of general exercise, motor control exercise and spinal manipulative therapy for chronic low back pain: A randomized trial. *Pain*. 2007;131(1-2):31-37.

32. Foss IS, Holme I, Bahr R. The prevalence of low back pain among former elite cross-country skiers, rowers, orienteers, and nonathletes: a 10-year cohort study. *The American Journal of Sports Medicine*. 2012;40(11):2610-2616.
33. Galambos SA, Terry PC, Moyle GM, Locke SA, Lane AM. Psychological predictors of injury among elite athletes. *British Journal of Sports Medicine*. 2005;39(6):351-354.
34. Gibbons LE, Videman T, Battie MC. Determinants of isokinetic and psychophysical lifting strength and static back muscle endurance: a study of male monozygotic twins. *Spine*. 1997;22(24):2983-2990.
35. Gill KP, Bennett SJ, Savelsbergh GJ, van Dieen JH. Regional changes in spine posture at lift onset with changes in lift distance and lift style. *Spine*. 2007;32(15):1599-1604.
36. Goel VK, Kong W, Han JS, Weinstein JN, Gilbertson LG. A combined finite element and optimization investigation of lumbar spine mechanics with and without muscles. *Spine*. 1993;18(11):1531-1541.
37. Grimmer K, Williams M. Gender-age environmental associates of adolescent low back pain. *Applied Ergonomics*. 2000;31(4):343-360.
38. Groholt EK, Stigum H, Nordhagen R, Kohler L. Recurrent pain in children, socio-economic factors and accumulation in families. *European Journal of Epidemiology*. 2003;18(10):965-975.
39. Hayden JA, van Tulder MW, Tomlinson G. Systematic review: strategies for using exercise therapy to improve outcomes in chronic low back pain. *Annals of Internal Medicine*. 2005;142(9):776-785.
40. Herreby M, Nygard B, Jessen T, Larsen E, Storr-Paulsen A, Lindahl A, et al. Risk factors for low back pain in a cohort of 1389 Danish school children: an epidemiologic study. *European Spine Journal*. 1999;8(6):444-450.
41. Hestbaek L, Leboeuf-Yde C, Kyvik KO, Manniche C. The course of low back pain from adolescence to adulthood: eight-year follow-up of 9600 twins. *Spine*. 2006;31(4):468-472.
42. Hickey GJ, Fricker PA, McDonald WA. Injuries to elite rowers over a 10-yr period. *Medicine & Science in Sports & Exercise*. 1997;29(12):1567-1572.

43. Hill JC, Whitehurst DGT, Lewis M, Bryan S, Dunn KM, Foster NE, et al. Comparison of stratified primary care management for low back pain with current best practice (STarT Back): a randomised controlled trial. *Lancet*. 2011;378(9802):1560-1571.
44. Hill JJ, Keating JL. A systematic review of the incidence and prevalence of low back pain in children. *Physical Therapy Reviews*. 2009;14(4):272-284.
45. Holt PJ, Bull AMJ, Cashman PM, McGregor AH. Kinematics of spinal motion during prolonged rowing. *International Journal of Sports Medicine*. 2003;24(8):597-602.
46. Hosea T, Bolard A, McCarthy K. Rowing injuries. *Post graduate advances in sports medicine*. 1989:University of Pennsylvania: Forum Medicum Inc.
47. Hosea TM, Hannafin JA. Rowing injuries. *Sports Health*. 2012;4(3):236-245.
48. Howell D. Musculoskeletal profile and incidence of musculoskeletal injuries in lightweight women rowers. *The American Journal of Sports Medicine*. 1984;12(4):278-281.
49. Hoy D, Bain C, Williams G, March L, Brooks P, Blyth F, et al. A systematic review of the global prevalence of low back pain. *Arthritis and Rheumatism*. 2012;64(6):2028-2037.
50. Jeffries LJ, Milanese SF, Grimmer-Somers KA. Epidemiology of adolescent spinal pain: a systematic overview of the research literature. *Spine*. 2007;32(27):2630-2637.
51. Kankaanpaa M, Laaksonen D, Taimela S, Kokko SM, Airaksinen O, Hanninen O. Age, sex, and body mass index as determinants of back and hip extensor fatigue in the isometric Sorensen back endurance test. *Archives of Physical Medicine and Rehabilitation*. 1998;79(9):1069-1075.
52. Karlson KA. Rowing: sport-specific concerns for the team physician. *Current Sports Medicine Reports*. 2012;11(5):257-261.
53. Kujala UM, Taimela S, Erikintalo M, Salminen JJ, Kaprio J. Low-back pain in adolescent athletes. *Medicine & Science in Sports & Exercise*. 1996;28(2):165-170.

54. Lamb DH. A kinematic comparison of ergometer and on-water rowing. *The American Journal of Sports Medicine*. 1989;17(3):367-373.
55. Last JM. A dictionary of epidemiology. In: Last JM, ed. *A Dictionary of Epidemiology*. second ed ed: Oxford, UK: Oxford University Press; 1988:103.
56. Leboeuf-Yde C, Kyvik KO. At what age does low back pain become a common problem? A study of 29,424 individuals aged 12-41 years. *Spine*. 1998;23(2):228-234.
57. Lis AM, Black KM, Korn H, Nordin M. Association between sitting and occupational LBP. *European Spine Journal*. 2007;16(2):283-298.
58. Mackenzie HAM, Bull AMJ, McGregor AH. Changes in rowing technique over a routine one hour low intensity high volume training session. *Journal of Sports Science and Medicine*. 2008;7(4):486-491.
59. Mannion AF, Dumas GA, Cooper RG, Espinosa FJ, Faris MW. Muscle fibre size and type distribution in thoracic and lumbar regions of erector spinae in healthy subjects without low back pain: normal values and sex differences. *Journal of Anatomy*. 1997;190(4):505-513.
60. Marras WS, Davis KG, Heaney CA, Maronitis AB, Allread WG. The influence of psychosocial stress, gender, and personality on mechanical loading of the lumbar spine. *Spine*. 2000;25(23):3045-3054.
61. Maurer M, Soder RB, Baldisserotto M. Spine abnormalities depicted by magnetic resonance imaging in adolescent rowers. *The American Journal of Sports Medicine*. 2011;39(2):392-397.
62. McGill SM. The biomechanics of low back injury: implications on current practice in industry and the clinic. *Journal of Biomechanics*. 1997;30(5):465-475.
63. McGregor A, Anderton L, Gedroyc W. The assessment of intersegmental motion and pelvic tilt in elite oarsmen. *Medicine & Science in Sports & Exercise*. 2002;34(7):1143-1149.
64. McGregor AH, Bull AM, Byng-Maddick R. A comparison of rowing technique at different stroke rates: a description of sequencing, force production and kinematics. *International Journal of Sports Medicine*. 2004;26(6):465-470.

65. McGregor AH, Patankar ZS, Bull AMJ. Spinal kinematics in elite oarswomen during a routine physiological "step test". *Medicine & Science in Sports & Exercise*. 2005;37(6):1014-1020.
66. McGregor AH, Patankar ZS, Bull AMJ. Longitudinal changes in the spinal kinematics of oarswomen during step testing. *Journal of Sports Science and Medicine*. 2007;6(1):29-35.
67. McGregor AH, Patankar ZS, Bull AMJ. Do men and women row differently? A spinal kinematic and force perspective. *Proceedings of the Institution of Mechanical Engineers. Part P, Journal of Sports Engineering and Technology*. 2008;222(2):77-83.
68. Miller AEJ, MacDougall JD, Tarnopolsky MA, Sale DG. Gender differences in strength and muscle fiber characteristics. *European Journal of Applied Physiology and Occupational Physiology*. 1993;66(3):254-262.
69. Mitchell T, O'Sullivan PB, Burnett AF, Straker L, Smith A. Regional differences in lumbar spinal posture and the influence of low back pain. *BMC Musculoskeletal Disorders*. 2008;9:152-162.
70. O'Sullivan F, O'Sullivan J, Bull AMJ, McGregor AH. Modelling multivariate biomechanical measurements of the spine during a rowing exercise. *Clinical Biomechanics*. 2003;18(6):488-493.
71. O'Sullivan P. Diagnosis and classification of chronic low back pain disorders: Maladaptive movement and motor control impairments as underlying mechanism. *Manual Therapy*. 2005;10(4):242-255.
72. O'Sullivan P, Beales D, Jensen L, Murray K, Myers T. Characteristics of chronic non-specific musculoskeletal pain in children and adolescents attending a rheumatology outpatients clinic: a cross-sectional study. *Pediatric Rheumatology Online Journal*. 2011;9(1):3.
73. O'Sullivan P, Dankaerts W, Burnett A, Straker L, Bargon G, Moloney N, et al. Lumbopelvic kinematics and trunk muscle activity during sitting on stable and unstable surfaces. *Journal of Orthopaedic & Sports Physical Therapy*. 2006;36(1):19-25.
74. O'Sullivan PB. 'Clinical instability' of the lumbar spine: its pathological basis, diagnosis and conservative management In: Jeffrey D. Boyling,

Nigel Palastanga, eds. *Grieve's modern manual therapy: the vertebral column*. Edinburgh ; New York: Churchill Livingstone; 2004.

75. O'Sullivan PB, Beales DJ, Smith AJ, Straker LM. Low back pain in 17 year olds has substantial impact and represents an important public health disorder: a cross-sectional study. *BMC Public Health*. 2012;12:100.
76. O'Sullivan PB, Mitchell T, Bulich P, Waller R, Holte J. The relationship between posture and back muscle endurance in industrial workers with flexion-related low back pain. *Manual Therapy*. 2006;11(4):264-271.
77. Olson MW, Li L, Solomonow M. Flexion-relaxation response to cyclic lumbar flexion. *Clinical Biomechanics*. 2004;19(8):769-776.
78. Panjabi MM. The stabilizing system of the spine. part i. function, dysfunction, adaptation, and enhancement. *Journal of Spinal Disorders*. 1992;5(4):383-389.
79. Panjabi MM. The stabilizing system of the spine. part ii. neutral zone and instability hypothesis. *Journal of Spinal Disorders*. 1992;5(4):390-397.
80. Parkinson S, Campbell A, Dankaerts W, Burnett A, O'Sullivan P. Upper and lower lumbar segments move differently during sit-to-stand. *Manual Therapy*. In Press.
81. Perich D. *Low back pain in schoolgirl rowers: prevalence, bio-psychosocial factors and prevention*. Perth: School of Exercise, Biomedical and Health Sciences, Edith Cowan University; 2010.
82. Perich D, Burnett A, O'Sullivan F, Perkins C. Low back pain in adolescent female rowers: A multi-dimensional intervention study. *Knee Surgery, Sports Traumatology and Arthroscopy*. 2011;19(1):20-28.
83. Perich D, Burnett A, O'Sullivan P. Low back pain and the factors associated with it: Examination of adolescent female rowers. 24th *International Symposium on Biomechanics in Sports*. July 14-18, 2006; Salzburg, Austria.
84. Perry MC, Straker LM, O'Sullivan PB, Smith AJ, Hands B. Fitness, motor competence and body composition are weakly associated with

- adolescent back pain. *Journal of Orthopaedic & Sports Physical Therapy*. 2009;39(6):439-449.
85. Pollock CL, Jenkyn TR, Jones IC, Ivanova TD, Garland SJ. Electromyography and kinematics of the trunk during rowing in elite female rowers. *Medicine & Science in Sports & Exercise*. 2009;41(3):628-636.
 86. Pollock CL, Jones IC, Jenkyn TR, Ivanova TD, Garland SJ. Changes in kinematics and trunk electromyography during a 2000 m race simulation in elite female rowers. *Scandinavian Journal of Medicine & Science in Sports*. 2012;22(4):478-487.
 87. Reid DA, Mcnair PJ. Factors contributing to low back pain in rowers. *British Journal of Sports Medicine*. 2000;34(5):321-322.
 88. Roffey DM, Wai EK, Bishop P, Kwon BK, Dagenais S. Causal assessment of awkward occupational postures and low back pain: results of a systematic review. *The Spine Journal*. 2010;10(1):89-99.
 89. Roy SH, De Luca CJ, Snyder-Mackler L, Emley MS, Crenshaw RL, Lyons J. Fatigue, recovery, and low back pain in varsity rowers. *Medicine & Science in Sports & Exercise*. 1990;22(4):463-469.
 90. Sato T, Ito T, Hirano T, Morita O, Kikuchi R, Endo N, et al. Low back pain in childhood and adolescence: a cross-sectional study in Niigata City. *European Spine Journal*. 2008;17(11):1441-1447.
 91. Sato T, Ito T, Hirano T, Morita O, Kikuchi R, Endo N, et al. Low back pain in childhood and adolescence: assessment of sports activities. *European Spine Journal*. 2011;20(1):94-99.
 92. Sheeran L, Sparkes V, Caterson B, Busse-Morris M, van Deursen R. Spinal position sense and trunk muscle activity during sitting and standing in nonspecific chronic low back pain: classification analysis. *Spine*. 2012;37(8):E486-495.
 93. Shehab D, Al-Jarallah K, Al-Ghareeb F, Sanaseeri S, Al-Fadhli M, Habeeb S. Is low-back pain prevalent among kuwaiti children and adolescents. *Medical Principles and Practice*. 2004;13(3):142-146.
 94. Shirazi A. Analysis of large compressive loads on lumbar spine in flexion and in torsion using a novel wrapping element. *Journal of Biomechanics*. 2006;39(2):267-275.

95. Sjolie AN. Persistence and Change in Nonspecific Low Back Pain Among Adolescents: A 3-Year Prospective Study. *Spine*. 2004;29(21):2452-2457.
96. Smith A, O'Sullivan P, Straker L. Classification of sagittal thoraco-lumbo-pelvic alignment of the adolescent spine in standing and its relationship to low back pain. *Spine*. 2008;33(19):2101-2107.
97. Smith AJ, O'Sullivan PB, Campbell AC, Straker LM. The relationship between back muscle endurance and physical, lifestyle, and psychological factors in adolescents. *Journal of Orthopaedic & Sports Physical Therapy*. 2010;40(8):517-523.
98. Smoljanovic T, Bojanic I, Hannafin JA, Hren D, Delimar D, Pecina M. Traumatic and overuse injuries among international elite junior rowers. *The American Journal of Sports Medicine*. 2009;37(6):1193-1199.
99. Soler T, Calderon C. The prevalence of spondylolysis in the Spanish elite athlete. *The American Journal of Sports Medicine*. 2000;28(1):57-62.
100. Solomonow M, Zhou B, Baratta RV, Yun L, Harris M. Biomechanics of increased exposure to lumbar injury caused by cyclic loading: part 1. loss of reflexive muscular stabilization. *Spine*. 1999;24(23):2426-2434.
101. Sparto PJ, Parnianpour M, Reinsel TE, Simon S. The effect of fatigue on multijoint kinematics and load sharing during a repetitive lifting test. *Spine*. 1997;22(22):2647-2654.
102. Stallard M. Backache in oarsmen. *British Journal of Sports Medicine*. 1980(14):105-108.
103. Stevenson JM, Weber CL, Smith JT, Dumas GA, Albert WJ. A longitudinal study of the development of low back pain in an industrial population. *Spine*. 2001;26(12):1370-1377.
104. Strahan AD, Burnett AF, Caneiro JP, Doyle MM, O'Sullivan PB, Goodman C. Differences in spinopelvic kinematics in sweep and scull ergometer rowing. *Clinical Journal of Sport Medicine*. 2011;21(4):330-336.

105. Straker LM, O'Sullivan PB, Smith A, Perry M. Computer use and habitual spinal posture in Australian adolescents. *Public Health Reports*. 2007;122(5):634-643.
106. Stutchfield BM, Coleman S. The relationship between hamstring flexibility, lumbar flexion, and low back pain in rowers. *European Journal of Sport Science*. 2006;6(4):255-260.
107. Suuden E, Ereline J, Gapeyeva H, Paasuke M. Low back muscle fatigue during Sorensen endurance test in patients with chronic low back pain: relationship between electromyographic spectral compression and anthropometric characteristics. *Electromyography and Clinical Neurophysiology*. 2008;48(3-4):185-192.
108. Sward L, Hellstrom M, Jacobsson B, Nyman R, Peterson L. Disc degeneration and associated abnormalities of the spine in elite gymnasts. A magnetic resonance imaging study. *Spine*. 1991;16(4):437-443.
109. Teitz CC, O'Kane J, Lind B, Hannafin JA. Back pain in intercollegiate rowers. *The American Journal of Sports Medicine*. 2002;30(5):674-679.
110. Teitz CC, O'Kane JOK, Lind BK. Back Pain in Former Intercollegiate Rowers A Long-term Follow-up Study. *The American Journal of Sports Medicine*. 2003;31(4):590-595.
111. Thorpe A. *Assessing the efficacy of a specific physiotherapy intervention for the prevention of low back pain in female adolescent rowers: a field study*. Perth: School of Physiotherapy, Curtin University of Technology; 2009.
112. Thorpe A, O'Sullivan P, Burnett A, Caneiro J-P. Assessing the efficacy of a specific physiotherapy intervention for the prevention of low back pain in female adolescent rowers: A field study. *New Zealand Journal of Sports Medicine*. 2009;32(2):38-46.
113. Trafimow JH, Schipplein OD, Novak GJ, Andersson GB. The effects of quadriceps fatigue on the technique of lifting. *Spine*. 1993;18(3):364-367.
114. Turner PG, Green JH, Galasko CS. Back pain in childhood. *Spine*. 1989;14(8):812-814.

115. Van Hoof W, Volkaerts K, O'Sullivan K, Verschueren S, Dankaerts W. Comparing lower lumbar kinematics in cyclists with low back pain (flexion pattern) versus asymptomatic controls - field study using a wireless posture monitoring system. *Manual Therapy*. 2012;17(4):312-317.
116. van Tulder MW, Becker A, Bekkering T, Breen A, del Real MTG, Hutchinson A, et al. Chapter 3 European guidelines for the management of acute nonspecific low back pain in primary care. *European Spine Journal*. 2006;15(Supp 2):S169-S191.
117. Waddell G, Burton AK. Concepts of rehabilitation for the management of low back pain. *Best practice & research. Clinical Rheumatology*. 2005;19(4):655-670.
118. Wade M, Campbell AC, Smith A, Norcott J, O'Sullivan P. Investigation of spinal posture signatures and ground reaction forces during landing in elite female gymnasts. *Journal of Applied Biomechanics*. 2012;28(6):677-686.
119. Walker BF. The prevalence of low back pain: a systematic review of the literature from 1966 to 1998. *Journal of Spinal Disorders*. 2000;13(3):205-217.
120. Wilson F, Gissane C, Gormley J, Simms C. A 12-month prospective cohort study of injury in international rowers. *British Journal of Sports Medicine*. 2010;44(3):207-214.
121. Wilson F, Gissane C, Gormley J, Simms C. Sagittal plane motion of the lumbar spine during ergometer and single scull rowing. *Sports Biomechanics*. 2013;12(2):132-142.
122. Wilson F, Gormley J. Kinematics of lumbar spine motion in rowing during a fatiguing protocol: A comparison of ergometer and boat rowing. *British Journal of Sports Medicine*. 2011;45(4):383.
123. Yoshiga CC, Higuchi M. Rowing performance of female and male rowers. *Scandinavian Journal of Medicine & Science in Sports*. 2003;13(5):317-321.

Chapter 3 - Study 1

Self-reported prevalence, pain intensity and risk factors of low back pain in adolescent rowers

Authors: Leo Ng, Debra Perich, Angus Burnett, Amity Campbell, Peter O'Sullivan

The specific aim of Study 1 was to:

- Investigate the prevalence, pain intensity and risk factors associated with low back pain in adolescent male rowers and compare this with results from adolescent female rowers

This manuscript has been accepted to the *Journal of Science and Medicine in Sport*

* The guideline for this journal stipulates a maximum of 30 references in total and no more than 3 references should be used to support a specific point in the text.

3.1 Abstract

Objectives: The primary objective of this study was to determine the lifetime and point prevalence of low back pain (LBP), the related pain intensity and the rowing-related aggravating factors for LBP in adolescent rowers who participated in school-level competitions. The secondary objective was to determine whether between-gender differences existed in these data.

Design: Retrospective cross-sectional survey

Method: 130 adolescent male and 235 adolescent female rowers aged between 14 to 16 years were recruited in this study. Participants completed a questionnaire to determine their lifetime and point prevalence of LBP, their pain intensity and rowing-related factors that aggravated their LBP.

Results: A high lifetime and point prevalence of LBP were found in both adolescent male (93.8% and 64.6% respectively) and female (77.9% and 52.8% respectively) rowers. A significant between-gender difference was reported for both statistics ($p < 0.001$). A significantly lower ($p = 0.003$) level of pain intensity via a visual analog scale was found for males (4.1/10) when compared to females (5.0/10). Similar rowing-related aggravating factors were reported by males and females although fewer males reported that lifting the rowing shell aggravated their LBP.

Conclusions: A high lifetime and point prevalence of LBP was reported by the adolescent rowers recruited in this study. While a greater proportion of adolescent male rowers reported LBP, they reported a lower intensity of pain when compared to their female counterparts. Coaches, clinicians and rowers should be made aware of these findings such that future research and development can focus on promoting pain management strategies in this sport.

Keywords: Prevalence; low back pain; adolescents; rowing

3.2 Introduction

The prevalence rate of low back pain (LBP) in adolescents in the general population ranges from 7% to 66% and this is known to vary according to a range of factors.^{2,8} For example, the prevalence rate has been shown to increase with age,⁸ and gender differences have also been reported in lifetime and point prevalence of LBP in the general adolescent population.^{8,17} A lower lifetime and point prevalence of LBP is known to be evident in adolescent males when compared to females, with lifetime prevalence in 14-year-olds reported to be 43.7% in males compared to 48.5% in females (n=1608)²¹ and point prevalence in 17-year-olds has been found to be 22.3% for males and 41.1% for females (n=1283).¹⁷ Understanding the prevalence of LBP in adolescent populations is important as it is a known risk factor for LBP in adulthood.⁷

Specific groups of adolescents appear to be at greater risk of developing LBP than others.^{17,21} Both retrospective surveys²⁵ and 12-month prospective phone interviews²⁹ have indicated that rowers of various ages and experience levels are at a high risk of developing LBP. Previous work has also found that gender differences exist in LBP incidence in rowers, with male rowers being reported to have a higher incidence of LBP when compared to female rowers in elite junior populations.²⁵ Smoljanovic and colleagues²⁵ reported that the incidence of LBP in international competitive elite junior rowers (median age of 18 years) was 32.3%. While the incidence for males was slightly higher than for females (34.4% as opposed to 29.9%), statistical analysis was not used to determine whether these differences were significant. No studies have been published investigating prevalence of LBP in adolescent rowers that compete in secondary school-level competitions. This age group and level of competition is of importance as many rowers learn how to row at this time through their schools.

There is also limited information regarding the factors potentially associated with rowing related LBP in adolescent populations. It is important to understand the aggravating factors in populations at risk of LBP in order to

better tailor management strategies. Therefore, several attempts to identify risk factors have been made with repeated spinal flexion loading coupled with high training volume and intensity reportedly linked with LBP in rowers.^{1,23,29} In another study of 2165 adult ex-rowers it was found that commencing rowing before the age of 16 years as well as having a larger body mass and greater height were associated with rowing related back pain,²⁶ although this retrospective survey may be associated with an element of recall bias. Further, the volume of ergometer rowing has been suggested to be a factor in the development of LBP^{26,29} and previous studies have also suggested that the increased lumbar flexion reported to occur during prolonged ergometer rowing is potentially related to LBP.^{22,30} Interestingly, no differences in injury rate were reported between sweep rowing (where the rowers use one oar) and scull rowing (where the rowers use two oars), although these injuries were not specific to the lumbar region.²⁹ To the best of our knowledge, no study has outlined or compared the aggravating factors associated with LBP in the adolescent male and female rowing populations. These aggravating factors may differ given that males row with a more slouched posture than females during ergometer rowing¹⁶ and males have greater strength but poorer relative back muscle endurance than females.¹²

There is currently a dearth of evidence regarding LBP prevalence, pain intensity and associated aggravating factors in amateur adolescent rowers. Therefore, the aim of this study was to quantify and compare the LBP prevalence (lifetime and point), pain intensity and rowing related aggravating factors in amateur adolescent male and female rowers.

3.3 Methods

The participants in this study included rowers who competed for independent boys and girls schools in Western Australia. After approaching the rowing coordinators at each of the associated schools, a total of 130 male rowers and 235 female rowers between 14-16 years of age participated in this study. This sample represented 42% and 72% of the schoolboy and schoolgirl rowing competitions respectively. The range of competitive rowing

experience for both male and female cohorts ranged from 1 to 4 years. The inclusion criteria for this study were; i) participants must have been training in a rowing school in preparation for regular rowing competition and ii) participants must be between 14 and 16 years of age. Permission to conduct this study was granted by the relevant institutional ethics committee (approval numbers HR 59/2010 and HR80/2005)(see appendix D). All participants that completed the questionnaire provided assent/consent from the school's rowing coordinators, coaches, individual rowers and their guardians prior to their participation (see appendix E).

Participants in this study completed a single questionnaire handed out by members of the research team at the start of the schoolboy and schoolgirl competitive rowing seasons. Participants completed the questionnaire in groups of 15-40 and members of the research team supplemented the questionnaire with verbal definitions (see below) and visual demonstrations where necessary prior to the questionnaire being filled in. Opportunity was also provided to the participants to clarify any queries they had.

The questionnaire (see appendix G) initially included questions on general characteristics such as age, height and mass. There were then questions relating to LBP. LBP was defined as pain located between L1 to gluteal folds and this area of the body was shown in a visual manner to the participants. The question relating to lifetime prevalence of LBP was adapted from the Nordic Musculoskeletal Questionnaire¹⁰ to include 'experience' in the question while the point prevalence (current status) of LBP question had been used in previous rowing-related research.^{19,27} The Visual Analogue Scale (VAS) was used to determine the usual level of LBP in the week prior to data collection.¹⁸ Rowers with LBP were then able to select factors from a list that brought on, or exacerbated their LBP. These factors were compiled through consultation with rowing coaches, rowers, researchers and clinicians as well as through examining previous research.^{19,27} This list included the following factors; lifting a rowing shell, rowing in a sweep boat, rowing in a quadruple scull, rowing in a single scull, ergometer rowing or long rows in a training session. They were also given the opportunity to specify other factors

that aggravated their LBP. It should be noted that the double scull was not provided as an option in this questionnaire as this boat was not used in rowing regattas. Further, the definition of a long row in a training session was verbally described to participants as more than 20 minutes of continuous ergometer or on-water rowing which was not the warm up part of training. The questionnaire concluded by assessing the number of rowing-related training hours and other sporting commitments (options were 0 hours, <5 hours or >5 hours).

Statistical analyses were performed using SPSSV19 (SPSS Inc., Chicago: USA). Means and standard deviations were used to present the participants' height, mass, age, weekly rowing training hours, and LBP intensity were presented for both adolescent male and female rowers. The LBP lifetime prevalence, point prevalence and aggravating factors were presented as a proportion of the sample. Independent t-tests were used to determine whether between-gender differences were evident in age, height and mass as well as for the weekly total training hours (on-water and on-land). Fisher's exact tests between two independent proportions were used to determine whether there were between-gender differences for lifetime prevalence, point prevalence and rowing related aggravating factors. This was done for each age group and for the entire cohort. The Mann-Whitney U test was used to determine whether differences in the intensity of LBP were evident between-gender. In order to control for the potential bias of participation in sports other than rowing, a secondary analysis was performed with the rowers split into two groups based on the number of hours the rowers reported spending on sports other than rowing per week (1 = <5 hours and 2 = >5 hours). Chi-square statistics (χ^2) were used to compare differences in the number of hours per week the male and female rowers participated in sports outside of rowing. An alpha level of 0.05 was used to represent statistical significance between genders in LBP prevalence and pain intensity. An alpha level of 0.01 was used to compare gender differences in aggravating factors to decrease the chance of making a type I error.

3.4 Results

No significant difference ($p=0.159$) was evident between-gender for age (males, 15.1 (0.8) years and females, 15.0 (0.8) years), however adolescent male rowers were significantly ($p<0.001$) taller (males, 1.79m (0.08) and females, 1.68m (0.08)) and heavier (71.0 kg (11.9) and 58.4 kg (8.9)) than females. These results were consistent across the three age groups of 14, 15 and 16 years ($p<0.01$).

There was a high lifetime and point prevalence of LBP in adolescent male and female rowers (Table 3.1). These prevalence rates were significantly higher in males when compared to females (Table 3.1). When grouped by age, males had significantly higher ($p=0.002$, $p=0.004$) lifetime prevalence at 14 and 15-years but not at 16 years ($p=0.250$) (Table 3.1). No significant differences were observed in point prevalence when grouped by age (Table 3.1).

Table 3.1 – Prevalence of LBP in adolescent rowers between genders

Participants			Lifetime Prevalence					Point Prevalence				
Age	Males	Females	Males n (%)	Females n (%)	P	Mean diff	95% CI	Males n (%)	Females n (%)	P	Mean diff	95% CI
14	36	117	36 (100)	95 (81.2)	0.002*	0.188	0.052, 0.273*	26 (72.2)	68 (58.1)	0.171	0.141	-0.057, 0.302
15	44	75	41 (93.2)	53 (70.7)	0.004*	0.225	0.064, 0.354*	28 (63.6)	33 (44.0)	0.057	0.196	-0.002, 0.373
16	50	43	45 (90.0)	35 (81.4)	0.250	0.086	-0.073, 0.252	30 (60.0)	23 (53.5)	0.537	0.065	-0.146, 0.270
Total	130	235	122 (93.8)	183 (77.9)	<0.001*	0.160	0.082, 0.228*	84 (64.6)	124 (52.8)	0.036*	0.119	0.008, 0.223*

* denotes statistical significant differences ($p < 0.05$) between genders

The VAS data indicated that the adolescent male rowers reported significantly lower intensity of LBP compared to the females (median difference: 1.1/10, 95%CI: 0.4 to 1.7, $p=0.003$) figure 3.1. This finding was consistent in the 14-year-old age group (median difference: 1.5/10, 95%CI: 0.4 to 2.7, $p=0.01$) but not for the 15 (median difference: 0.6/10, 95%CI: -0.3 to 1.8, $p=0.144$) or 16 year old groups (median difference: 1.0/10, 95% CI: -0.4 to 2.6, $p=0.185$).

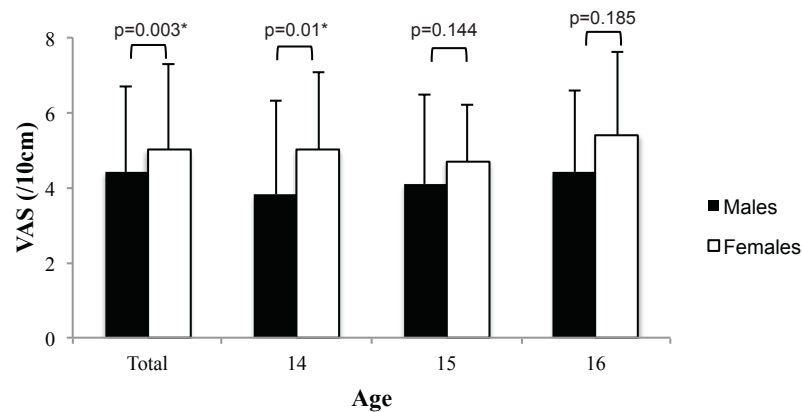

Figure 3.1 – Self reported pain intensity between adolescent male and female rowers

* denotes statistical significant differences ($p<0.05$) between genders

Both males and females identified long rows in a training session, sweep rowing and ergometer rowing to be associated with aggravation of their LBP (Table 3.2). However, males (25.6%) were less likely ($p<0.001$) than females (65.1%) to identify lifting a rowing shell to exacerbate their LBP.

Table 3.2 – Self-reported rowing related aggravating factors to LBP between genders

		Lifting rowing shell	Ergometer rowing	Long rows in training session	Sweep rowing in an eight	Rowing in quadruple scull	Rowing in single scull
Females	Number (n=86)	56	38	67	52	29	14
	Percentage	(65.1%)	(44.2%)	(77.9%)	(60.5%)	(33.7%)	(16.3%)
Males	Number (n=121)	31	48	78	71	26	18
	Percentage	(25.6%)	(39.7%)	(64.5%)	(58.7%)	(21.5%)	(18.2%)
Mean difference		0.395	0.045	0.134	0.018	0.122	0.014
p-value		P<0.001*	P=0.568	P=0.045	P=0.886	P=0.056	P=0.853
99% CI		0.228, 0.562*	-0.134, 0.224	-0.026, 0.295	-0.160, 0.196	-0.040, 0.285	-0.118, 0.146

* denotes statistical significant differences (p<0.05) between genders

Adolescent male rowers completed more hours per week of rowing related training (8.6 (2.8) hours) when compared to the females (7.5 (2.7) hours) (95%CI: 0.5 to 1.7, $p < 0.001$). However, no between-gender differences were evident for the number of hours per week the rowers participated in physical activities outside of rowing ($\chi^2 = 2.922$, $df = 2$, $p = 0.232$).

3.5 Discussion

The results of this study suggest that the LBP prevalence reported by adolescent male and female rowers were higher than a representative cohort in the general population of Western Australia^{17,21} and worldwide.² The rowers reported a higher lifetime LBP prevalence (93.8% in adolescent males and 77.9% in females) than a cohort of 14-year-olds representative of the general population in Australia (43.7% in males and 48.5% females)²¹ and a meta analysis of 59 studies conducted on adolescents worldwide (39.9% lifetime prevalence in male and female adolescents with a mean age of 13.6 years).² The rowers also reported a point prevalence of LBP that specifically occurred during rowing that week, that was greater than the LBP point prevalence that day in 17-year-olds (22.3% males and 41.1% females),¹⁷ and adolescents with a mean age of 13.6 years worldwide (12.0% combined males and females).² While there is little direct evidence regarding the most likely mechanisms for this higher LBP prevalence, it has been proposed that the cyclic flexion loading of the lumbar spine that has been demonstrated to occur in the rowing stroke may be related.^{1,9,23}

The results of this study also found that there was a higher lifetime and point prevalence of LBP in adolescent male rowers compared to adolescent female rowers that were matched for age and amount of hours spent performing sports outside of rowing. However, the male rowers performed significantly more hours of training than adolescent female rowers and higher training volume has been linked to LBP and injuries in rowers.^{20,29} These groups were not matched for height and mass, which may influence the result, as rowers who are taller and

heavier are at greater risk of self reported LBP in the general population, which supports the findings from this study.^{25,26} This finding is in contrast to reports in the general population where adolescent females reported a higher prevalence of LBP than males^{17,21} but supports previously described findings from elite junior rowing populations.²⁵

Differences in the prevalence of LBP between genders in adolescent rowers could be due to a number of factors. Firstly, differences in spinal kinematics during ergometer rowing have been reported in this age group, with males typically sitting in greater posterior pelvic tilt and spending more time with their upper trunk in flexion compared to females.¹⁶ Spinal kinematics during ergometer has been suggested to be linked with LBP, with the increase in spinal flexion over time during ergometer rowing^{22,30} and the lumbar spine moving closer to end of range both suggested to be associated with LBP.^{1,15} Secondly, adult male rowers have the ability to generate higher forces and output, due to having larger cross sectional muscle area and muscle fiber size than females.¹² This has been reflected in greater peak force generation in males during ergometer rowing.¹³ However, it is unknown whether gender differences in muscle strength are present in the adolescent rowing population. Thirdly, evidence suggests that healthy adolescent females have greater endurance in their back muscles compared with adolescent males.²⁴ Poor back muscle endurance has been shown to be associated with LBP in the general population.^{21,24} Furthermore, interventions to address such deficits have been shown to be effective in reducing LBP in adolescent female rowers.^{20,27}

Interestingly, the results also demonstrated that the lifetime and point prevalence of LBP in adolescent male rowers decreased with increasing age, which is a contrasting trend to that reported in the general population and the female rowers.⁸ The female rowers' prevalence of LBP was less in the 15-year-old rowers compared with the 14-year-olds, but greater in the 16-year-olds compared to the 15-year-olds. There was consistency in the age that both male

and female rowers are at greatest risk of LBP, with the youngest age (14-year-olds) reporting the greatest prevalence of LBP. This may be due to the fact that this is the age that the adolescents are typically first exposed to rowing.

Therefore, coaches attempt to accelerate their learning by spending time with the group on-water to teach them the basic technical skills of rowing. This age group (12-14) is at the beginning of rapid growth and may be at greater risk of developing back pain by loading their developing spine at this stage of development.⁶ The rise in prevalence between the 15 and 16-year-old females age groups could relate to increased training load during their final year of competition in preparation for the most prestigious race in the school rowing competition. However, this is also the case in the males, but the opposite occurred (i.e. reduced LBP prevalence). Finally, differences in prevalence with age could be due to different understanding of LBP in this age group. A recent study has shown that the understanding of LBP consequences is affected by the age of the individual.¹¹

The results of this study found that both adolescent male and female rowers with LBP reported on average a moderate level of pain intensity, which is defined as a self reported rating on the VAS of greater than 3 (figure1).³ Male rowers reported statistically less pain intensity on the VAS compared to the females when age groups were combined and when compared at 14 and 15 years. This may be related to previous indications that females have lower pain thresholds compared to males⁴ with the differences likely due to interplay of genetic, neurophysiological, hormonal and psychological factors.⁵ However, this one point difference is of questionable clinical significance.

Common aggravating factors identified by both adolescent male and female rowers were ergometer rowing, long rows in a training session and sweep rowing in an eight (where there are 8 rowers and a coxswain on a rowing shell). This supports previous evidence that ergometer rowing and long rowing sessions are activities associated with back pain.^{19,26,29} The prolonged and

repetitive flexion loading of the spine during these rowing related activities may cause strain and pain in the back.^{9,23} Furthermore, increased lumbar flexion and end range flexion loading in rowers has also been identified to be associated with LBP.^{15,22,30} A large proportion of rowers also identified sweep rowing to be associated with LBP in this study, this is in contrast to results that were published in the elite adult population that reported no differences in injury rate between sweep and scull rowers in a 12-month prospective study on 20 elite male rowers.²⁹ The only gender differences in aggravating factors were that less adolescent male rowers reported lifting a rowing shell to be an aggravating factor to their LBP. This may be due to the mass of the shell relative to body mass, as females were significantly lighter than males in this study, and females are known to be weaker than males which may leave them more vulnerable when lifting the shell.¹²

The results of this study are limited to the local rowing samples surveyed. The sample sizes for the two cohorts were uneven due to three rowing coordinators in the boys schools not providing consent to participate in this study and this may have affected the prevalence estimates and thus the comparisons. Further, given that the adolescent age group is a time of rapid physical and mental growth, and growth rates differ between males and females this may have affected the LBP pain prevalence comparisons although this does not concur with population data.²¹ Also, LBP as a result of menstruation was not considered in this study, which may over report the LBP prevalence in adolescent females. LBP should also be considered from a psychological and physiological perspective,²⁸ however in this study, psychological data (such as anxiety and depression), pain threshold data and disability measures were not gained. Although data collection was conducted at the beginning of the rowing season (within 2 weeks before the first rowing regatta), the exact date could not be standardised between groups, therefore there may be differences in training volume in exact time of data collection. As this was a retrospective survey, there may be some recall bias in the lifetime prevalence data. Specifically, it is likely that

these adolescents could have been more likely to recall more severe LBP episodes.¹⁴ Finally, although the questionnaire has not been formally validated, it has been found to correlate with clinical pain and results of this have been published in previous research on adolescent rowers.^{19,27}

3.6 Conclusion

Adolescent male rowers had higher reported lifetime and point prevalence of LBP compared to adolescent female rowers. Both groups who indicated they had LBP reported a moderate level of pain intensity, and that the following factors aggravated their LBP; ergometer rowing, long rowing sessions and sweep rowing. The results of this research support the need for further investigation into understanding the etiology and impact of rowing in adolescents, as well as developing interventions to prevent and manage this problem.

3.7 Practical implications

- There is a higher prevalence of LBP in adolescent male rowers compared to adolescent female rowers.
- Adolescent rowers experience moderate levels of LBP intensity.
- Adolescent male and female rowers reported similar aggravating factors, with ergometer rowing, long row in training session and sweep rowing most likely to aggravate their LBP.

3.8 Acknowledgements

The authors wish to acknowledge the Independent Girls' Schools' Sporting Association of Western Australia, School of Physiotherapy, Curtin University for funding this study and all of the rowers and coaches who participated.

3.9 References

1. Caldwell JS, McNair PJ, Williams M. The effects of repetitive motion on lumbar flexion and erector spinae muscle activity in rowers. *Clinical Biomechanics*. 2003;18:704-711.
2. Calvo-Munoz I, Gomez-Conesa A, Sanchez-Meca J. Prevalence of low back pain in children and adolescents: a meta-analysis. *BMC Pediatrics*. 2013;13:14.
3. Collins SL, Moore RA, McQuay HJ. The visual analogue pain intensity scale: what is moderate pain in millimetres? *Pain*. 1997;72:95-97.
4. Fillingim RB. Sex, gender, and pain: women and men really are different. *Current Review of Pain*. 2000;4:24-30.
5. Greenspan JD, Craft RM, LeResche L, Arendt-Nielsen L, Berkley KJ, Fillingim RB, et al. Studying sex and gender differences in pain and analgesia: A consensus report. *Pain*. 2007;132:S26-S45.
6. Grimmer K, Williams M. Gender-age environmental associates of adolescent low back pain. *Applied Ergonomics*. 2000;31:343-360.
7. Hestbaek L, Leboeuf-Yde C, Kyvik KO, Manniche C. The course of low back pain from adolescence to adulthood: eight-year follow-up of 9600 twins. *Spine*. 2006;31:468-472.
8. Hill JJ, Keating JL. A systematic review of the incidence and prevalence of low back pain in children. *Physical Therapy Reviews*. 2009;14:272-284.
9. Hosea T, Bolard A, McCarthy K. Rowing injuries. *Post Graduate Advances in Sports Medicine*. 1989;University of Pennsylvania: Forum Medicum Inc.
10. Kuorinka I, Jonsson B, Kilbom A, Vinterberg H, Biering-Sorensen F, Andersson G, et al. Standardised Nordic questionnaires for the analysis of musculoskeletal symptoms. *Applied Ergonomics*. 1987;18:233-237.
11. Leboeuf-Yde C, Fejer R, Nielsen J, Kyvik KO, Hartvigsen J. Consequences of spinal pain: do age and gender matter? A Danish

cross-sectional population-based study of 34,902 individuals 20-71 years of age. *BMC Musculoskeletal Disorders*. 2011;12:39.

12. Mannion AF, Dumas GA, Cooper RG, Espinosa FJ, Faris MW. Muscle fibre size and type distribution in thoracic and lumbar regions of erector spinae in healthy subjects without low back pain: normal values and sex differences. *Journal of Anatomy*. 1997;190:505-513.
13. McGregor AH, Patankar ZS, Bull AMJ. Do men and women row differently? A spinal kinematic and force perspective. *Proceedings of the Institution of Mechanical Engineers. Part P, Journal of Sports Engineering and Technology*. 2008;222:77-83.
14. Milanese S, Grimmer-Somers K. What is adolescent low back pain? Current definitions used to define the adolescent with low back pain. *Journal of Pain Research*. 2010;3:57-66.
15. Ng L, Burnett A, O'Sullivan P. Spino-pelvic kinematics and trunk muscle activation in prolonged ergometer rowing: mechanical etiology of non-specific low back pain in adolescent rowers. *26th International Conference on Biomechanics in Sports; July 14-18, 2008; Seoul, South Korea*.
16. Ng L, Campbell AC, Burnett A, O'sullivan P. Gender differences in trunk and pelvic kinematics during prolonged ergometer rowing in adolescents. *Journal of Applied Biomechanics*. 2013;29:180-187.
17. O'Sullivan PB, Beales DJ, Smith AJ, Straker LM. Low back pain in 17 year olds has substantial impact and represents an important public health disorder: a cross-sectional study. *BMC Public Health*. 2012;12:100.
18. Ogon M, Krismer M, Sollner W, Kantner-Rumplmair W, Lampe A. Chronic low back pain measurement with visual analogue scales in different settings. *Pain*. 1996;64:425-428.
19. Perich D. Low back pain in schoolgirl rowers: prevalence, bio-psycho-social factors and prevention [thesis]. Perth: Edith Cowan University; 2010.

20. Perich D, Burnett A, O'Sullivan F, Perkins C. Low back pain in adolescent female rowers: A multi-dimensional intervention study. *Knee Surgery, Sports Traumatology and Arthroscopy*. 2011;19:20-28.
21. Perry MC, Straker LM, O'Sullivan PB, Smith AJ, Hands B. Fitness, motor competence and body composition are weakly associated with adolescent back pain. *Journal of Orthopaedic & Sports Physical Therapy*. 2009;39:439-449.
22. Pollock CL, Jones IC, Jenkyn TR, Ivanova TD, Garland SJ. Changes in kinematics and trunk electromyography during a 2000 m race simulation in elite female rowers. *Scandinavian Journal of Medicine & Science in Sports*. 2012;22:478-487.
23. Reid DA, McNair PJ. Factors contributing to low back pain in rowers. *British Journal of Sports Medicine*. 2000;34:321-322.
24. Smith AJ, O'Sullivan PB, Campbell AC, Straker LM. The relationship between back muscle endurance and physical, lifestyle, and psychological factors in adolescents. *Journal of Orthopaedic & Sports Physical Therapy*. 2010;40:517-523.
25. Smoljanovic T, Bojanic I, Hannafin JA, Hren D, Delimar D, Pecina M. Traumatic and overuse injuries among international elite junior rowers. *The American Journal of Sports Medicine*. 2009;37:1193-1199.
26. Teitz CC, O'Kane J, Lind B, Hannafin JA. Back pain in intercollegiate rowers. *The American Journal of Sports Medicine* 2002;30:674-679.
27. Thorpe A, O'Sullivan P, Burnett A, Caneiro J-P. Assessing the efficacy of a specific physiotherapy intervention for the prevention of low back pain in female adolescent rowers: A field study. *New Zealand Journal of Sports Medicine*. 2009;32:38-46.
28. Waddell G. Modern management of spinal disorders. *Journal of Manipulative Physiological Therapy*. 1995;18:590-596.
29. Wilson F, Gissane C, Gormley J, Simms C. A 12-month prospective cohort study of injury in international rowers. *British Journal of Sports Medicine*. 2010;44:207-214.

- 30.** Wilson F, Gissane C, Gormley J, Simms C. Sagittal plane motion of the lumbar spine during ergometer and single scull rowing. *Sports Biomechanics*. 2013;12:132-142.

Chapter 4 - Study 2

Caution: The use of an electromagnetic device to measure spinal motion on rowing ergometers

Authors: Leo Ng, Angus Burnett, Peter O'Sullivan, Amity Campbell.

The specific aim of study was to:

- To validate the use of an electromagnetic motion analysis system to measure spinal kinematics during ergometer rowing.

Study 2 was published in *Sports Biomechanics*. 2009. 8(3): 255-259.

This is an Author's Original Manuscript of an article whose final and definitive form, the Version of Record, has been published in the Sports Biomechanics (2009) (copyright Taylor & Francis), available online at: <http://www.tandfonline.com/10.1080/14763140903229492>.

4.1 Abstract

The aim of the study was to determine the accuracy and variability of an electromagnetic device in measuring spinal kinematics on a traditional and replica rowing ergometer. Kinematic data collected from the 3-Space Fastrak™ system using a Standard Concept II ergometer were compared with a replica ergometer that was in part, composed of non-ferrous materials (modified ergometer). The Fastrak's sensors were fixed to a wooden 'spine' with known angles (as measured by an inclinometer). The mean inclinometer angle from four sensors ($1^{\circ} \pm 0.2$) was significantly different than the mean angle recorded on the standard ergometer ($-5.4^{\circ} \pm 3.4$) ($p = 0.007$) whilst the angles recorded on the modified ergometer ($1.4^{\circ} \pm 0.8$) were statistically equivalent to the inclinometer recordings ($p = 0.660$). These results indicate that the presence of ferrous material in a standard ergometer reduced the accuracy and increased the variability of data collected with the electromagnetic device. However, information collected on largely non-ferrous ergometers can provide coaches, biomechanists and clinicians with a quick and effective way to measure trunk motion during ergometer rowing.

4.2 Introduction

Low back pain (LBP) has been associated with rowers of all competitive standards.^{3,6} Despite the strong association found between mechanical factors, such as ergometer rowing during training and LBP,^{3,8} there remains a paucity of research into spinal kinematics in rowing.

Electromagnetic devices such as Flock of Birds™ (Ascension Technology, Burlington, Vt, USA) and 3-Space Fastrak™ (Polhemus Navigation Science Division) are popular measurement devices for the accurate recording of three-dimensional kinematics.^{1,7} Such devices have been found to be a useful tool in clinical assessments of patients with spinal disorders, offering a quick and efficient quantification of trunk kinematics.⁵ They have also been used to analyse trunk movement in rowers during ergometer rowing trials.^{2,4} The benefits of these devices over optical based biomechanical systems include; the relative ease of transport for testing at a range of venues, quicker administration and the short time frame required for data output.^{1,7} However, the accuracy of these systems is affected when recording is carried out near ferrous material.^{1,7} Therefore, the measurement of lumbar spine kinematics using a Rowing Ergometer (such as the Concept II) might be compromised by the numerous ferrous components.

The aim of this study was to quantify the accuracy of 3-Space Fastrak™ data collected using the Standard Concept II ergometer, in comparison with a modified version where the ferrous materials were replicated and replaced with wooden components (Modified Concept II ergometer).

4.3 Methods

In this study, kinematic data were collected using the 3-Space Fastrak™. This device was demonstrated to be a valid and reliable measurement tool with average errors of less than 0.2°.⁵ The 3-Space Fastrak™ consists of a systems

electronic unit, a source and four sensors. The source emits a low frequency magnetic field that the sensors use to detect their relative three-dimensional (3D) position and orientation. The three-dimensional orientation system of each sensor was defined using a right-handed coordinate system, as per the biomechanical standard.⁹ The X-axis was positive in the superior direction, the Y-axis was positive laterally in the right direction, and the Z-axis was positive in the anterior direction. The sensor orientation was decomposed by the Fastrak™ relative to the global orientation system (source) using a ZYX ordered sequence of rotations. The interpretation of the outputs using this ordered sequence of rotations was elevation, azimuth, and roll. The raw output from the Fastrak™ system was processed by a custom designed LabVIEW V8.2 (National Instruments, Texas, USA) software package.

Two rowing ergometers were used in this study; a standard Concept II rowing ergometer and the same ergometer but in a modified state. The standard Concept II ergometer was modified such that the beam and footings were replaced with non-ferrous components (wood) of identical dimension. The only remaining ferrous materials were three metal support screws in the beam. To replicate a static human spine, four Fastrak™ sensors were placed on a rigid wooden model (Figure 4.1). A rigid wooden model was chosen over a dynamic model such that the angles generated from the model can be compared with an inclinometer. Dynamic models were considered in this study but the need of ferrous material to build such a model could interfere with the results during measurements. Difficulties would also arise from selecting a criterion measure in a dynamic model as electromagnetic motion analysis systems are more accurate and reliable than optical measurements.⁷ The Fastrak's sensors were purposely positioned in various magnitudes of relative flexion and extension and located at different distances from the source as distance between source and sensors were linked to accuracy and variability in electromagnetic devices.⁷ While altering the source position could also affect the magnitude of error, this was not analysed given that there was only one feasible location for the source

on the ergometer. A pilot analysis revealed that securing the source on a rigid wooden plank attached to the sliding seat of the ergometer would not affect the rowing technique (Figure 4.1).

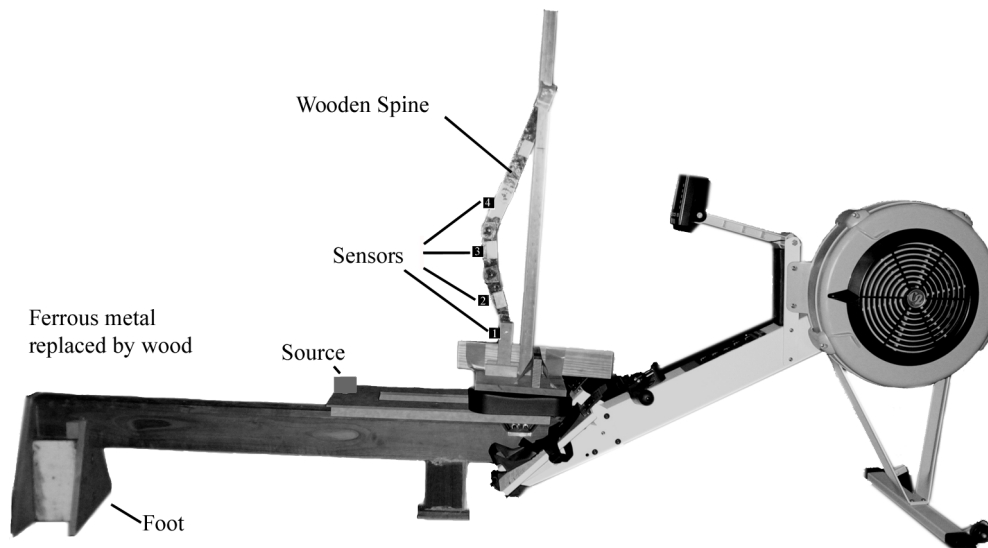

Figure 4.1 - Fastrak source and sensor positions on a wooden spine on a modified ergometer (with ferrous material replaced with wood)

To assess the Fastrak™ kinematics on both the standard and modified ergometers, the rigid wooden model was secured to the seat on the respective ergometers and moved forward and backwards five times along the entire length of the monorail (1.4m) at the same frequency between trials (22 strokes per minute) simulating five cycles (drive and recovery) of the rowing motion. This process was repeated twice to replicate multiple data collection during rowing trials in the protocol described in a previous study.⁴ Data were collected at a frequency of 25 Hz by the Fastrak™. Only elevation angles were examined in this investigation as spinal movements occur most in the sagittal plane when rowing on a centre pull ergometer. Further to this, lumbar flexion activities during rowing were linked to LBP⁴, which will be closely investigated in future kinematic studies in rowing. The inclinometer reading was considered the criterion measure as it could not be affected by the presence of ferrous material. Data

analysis included measures of accuracy and variability. Accuracy of the Fastrak™ angles on respective ergometer's were determined by comparing to the values measured with an inclinometer. Two sample t-tests were conducted between the angles (and the mean of all sensors) measured by the inclinometer and the output angles from the 3-Space Fastrak™ on the modified ergometer and standard ergometer, respectively. Variability was assessed by measuring the standard deviation of the measured signals throughout the simulated rowing strokes.

Table 4.1. Fastrak™ output from a standard ergometer and a modified ergometer compared with inclinometer reading

	Standard Ergometer		Modified Ergometer		Inclinometer (criterion measure)
	Angle (SD)	<i>p</i> -value	Angle (SD)	<i>p</i> -value	
Sensor 1	-6.0 (2.8)	<i>p</i> =0.008	-0.5 (1.0)	<i>p</i> =0.413	-1 (0.3)
Sensor 2	12.8 (3.4)	<i>p</i> =0.007	19.9 (0.7)	<i>p</i> =0.815	20 (0.3)
Sensor 3	-0.7 (3.4)	<i>p</i> =0.004	6.1 (0.6)	<i>p</i> =0.960	6 (0)
Sensor 4	-27.6 (4.0)	<i>p</i> =0.005	-20.1 (0.8)	<i>p</i> =0.835	-20 (0)
Mean of four sensors	-5.4 (3.4)	<i>p</i> =0.007	1.4 (0.8)	<i>p</i> =0.660	1 (0.2)

4.4 Results

The results demonstrated that the Fastrak™ angles recorded on the Modified Ergometer were closer to the known angles (inclinometer measures), than the standard ergometer (Table 4.1). The mean of all angles received from the three trials by the Fastrak's four sensors was -5.4° in the Standard Ergometer, which was significantly different to the 1.4° value recorded with the inclinometer (*p*=0.007). The sensors furthest away from the source (sensor 4) produced the largest error of 7.6°, while the sensor located closest to the source (sensor 1) recorded the least error of 5.0°. In comparison, the 1.4° mean Fastrak angles using the Modified Ergometer were statistically equal to the 1° inclinometer angle (*p*=0.660). This indicates that the 6.4° error that can be expected when using

Fastrak™ sensors on a Standard Ergometer, can be reduced to a 0.4° error by using the Modified Ergometer. The average of the standard deviation obtained from all four sensors was less in the Modified Ergometer (0.8°) as compared to the Standard Ergometer (3.4°).

4.5 Discussion and implications

There is a paucity of investigations addressing the link between trunk mechanics and LBP in rowing. Therefore, there is a need for goniometry-type devices to accurately analyse the spinal kinematics of rowing, which has the potential to reduce the incidence of injuries and optimise performance. An electromagnetic device such as the 3-Space Fastrak™ system is capable of measuring accurate real time spinal angles during rowing.⁵ However, the validity and reliability of using the 3-Space Fastrak™ on a standard ergometer has not been tested previously, and may be compromised by numerous ferrous materials.

The results of this study indicate that the material on a standard Concept II ergometer did affect the accuracy and variability of the data. It was also worth noting that this error increased with greater distance between the sensor and the source, as suggested in Richards (1999). Furthermore, a large amount of variation occurred as the source and the sensors passed the foot of the ergometer (Figure 4.2). The foot of a standard Concept II ergometer was made of mild steel, the beam was made of a stainless-steel track capped with aluminum rail (Concept II user guide). The difference in ferrous material content in different parts of the ergometer may contribute to the large variability of the data. By modifying the Concept II ergometer by replicating ferrous components with wood, the data output were consistent with the known angles (0.4° of error) and demonstrated minimal variability. The source and sensor appeared unaffected by this small amount of ferrous material (three support screws on the beam), with no variations evident in the Fastrak™ output (Figure 4.2).

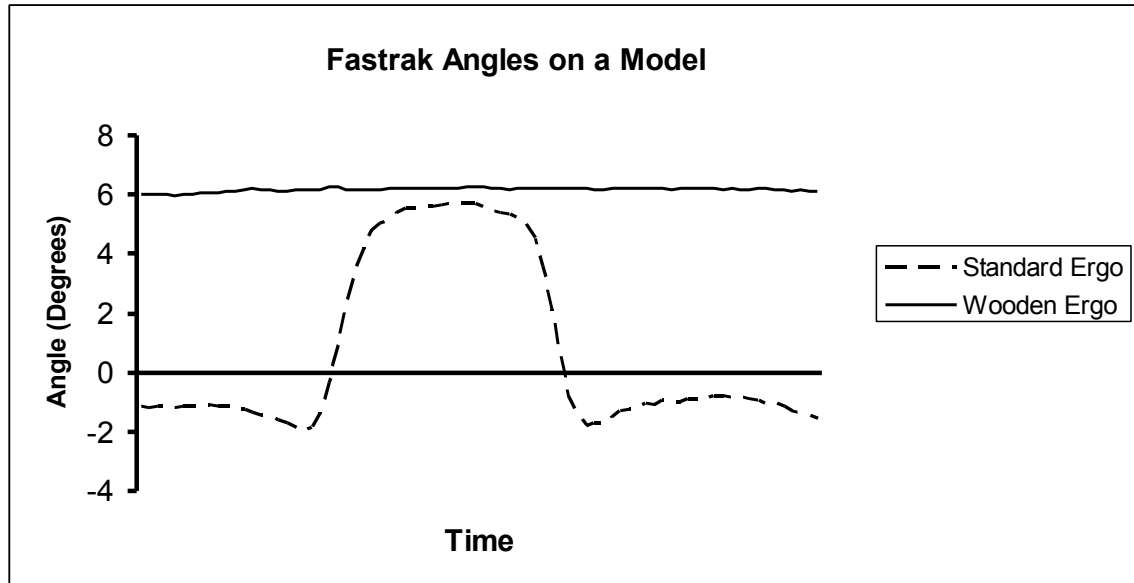

Figure 4.2 – The variability of Sensor 3 during one rowing cycle. The rise in angles on the standard ergometer coincided with the source and sensors moving past the foot of the standard ergometer (Figure 4.1)

This study was limited to the examination of a static spine model. Analysis of the error associated with a dynamic model and the effects of different sliding velocities might provide further evidence of the error expected during an actual rowing trial on a standard ergometer. Future studies examining kinematics in ergometer rowing may also include the use of other nonferrous material such as molded thermoplastic; such material may provide less friction between the beam and the seat.

4.6 Conclusion

This study verified that an electromagnetic device, such as that used in this study, may not produce valid results when recording on a standard Concept II ergometer. However, a rowing ergometer when modified to include non-ferrous materials can be used to accurately determine spinal kinematics during rowing.

4.7 References

1. An KN, Jacobsen MC, Berglund LJ, Chao EYS. Application of a magnetic tracking device to kinesiological studies. *Journal of Biomechanics*. 1988;21:613-620.
2. Bull AMJ, McGregor AH. Measuring spinal motion in rowers: the use of an electromagnetic device. *Clinical Biomechanics*. 2000;15:772-776.
3. Hickey GJ, Fricker PA, McDonald WA. Injuries to elite rowers over a 10-yr period. *Medicine & Science in Sports & Exercise*. 1997;29:1567-1572.
4. Ng L, Burnett A, O'Sullivan P. Spino-pelvic kinematics and trunk muscle activation in prolonged ergometer rowing: mechanical etiology of non-specific low back pain in adolescent rowers. *26th International Conference on Biomechanics in Sports*; July 14-18, 2008. Seoul, South Korea.
5. Percy MJ, Hindle RJ. New method for the on-invasive three-dimensional measurement of human back movement. *Clinical Biomechanics*. 1989;4:73-79.
6. Perich D, Burnett A, O'Sullivan P. Low back pain and the factors associated with it: Examination of adolescent female rowers. *24th International Conference on Biomechanics in Sports*; July 14-18. Salzburg, Austria: 2006.
7. Richards JG. The measurement of human motion: A comparison of commercially available systems. *Human Movement Science*. 1999;18:589-602.
8. Teitz CC, O'Kane J, Lind B, Hannafin JA. Back pain in intercollegiate rowers. *The American Journal of Sports Medicine*. 2002;30:674-679.
9. Wu G, Cavanagh PR. ISB recommendations for standardization in the reporting of kinematic data. *Journal of Biomechanics*. 1995;28:1257-1261.

Chapter 5 - Study 3

Gender differences in trunk and pelvic kinematics during prolonged ergometer rowing in adolescents

Authors: Leo Ng, Amity Campbell, Angus Burnett, Peter O'Sullivan.

The specific aim of Study 3 was:

- To compare the regional lumbar, pelvic and thoracic spine kinematics between healthy adolescent male and female rowers during ergometer rowing.

Study 3 was published in *Journal of Applied Biomechanics* 2013. 23(2): 180-187.

This is an Author's Original Manuscript of an article whose final and definitive form, the Version of Record, has been published in the Journal of Applied Biomechanics (2013) available online at: <http://journals.humankinetics.com/jab-back-issues/jab-volume-29-issue-2-april/gender-differences-in-trunk-and-pelvic-kinematics-during-prolonged-ergometer-rowing>

5.1 Abstract

The trunk and pelvis kinematics of 20 healthy adolescent male and female rowers were recorded during an ergometer trial using an electromagnetic tracking system (Fastrak). The kinematics of each drive phase were collected during the 1st and 20th minute, respectively. The mean and range of the kinematics, stroke rate and stroke length, were compared between genders and over time. Male rowers postured their pelvis with more posterior tilt and their thoracic spine in more flexion than female rowers ($p < 0.05$). Both genders postured their pelvis in more posterior pelvic rotation and upper trunk in more flexion over time. Male rowers were found to have a significantly shorter drive phase than female rowers ($p = 0.001$). Differences in trunk and pelvic kinematics between adolescent male and female rowers potentially suggest various mechanisms for biomechanical stress. Assessment and training of rowers should take gender differences into consideration.

5.2 Introduction

Rowing is a popular sport that males and females from school age to the international level compete in. It has been reported that the trunk accounts for a large amount of the force generation that directly results in ergometer and boat linear velocity.¹ This places significant stresses through the spine's structures at end of range flexion,² and likely contributes to the high prevalence of low back pain (LBP) consistently observed in rowers of all ages.³⁻⁷ Despite the sport's popularity and prevalence of LBP in the adolescent age group,^{4,7} there is a lack of biomechanical studies on this specific population.

There is a gender disparity in injury prevalence in elite rowers, for example, LBP is the most commonly reported injury in males (25.0%) in comparison to only 15.2% in females, who are more susceptible to chest wall injuries (22.6%), suffered by only 6% of males.³ This disparity may reflect different risk factors between genders in rowing. Therefore, understanding performance and spatiotemporal kinematic differences between-gender in adolescent rowers will allow clinicians to better manage injury risk factors, with further implications for coaches' to optimise performance.⁴

Gender differences have been explored in elite adult populations during ergometer rowing where differences in performance,^{8,9} force generation and pelvic kinematics were reported.¹⁰ Yoshiga and Higuchi (2003) reported that men aged between 18 to 24 years rowed 10% faster than females of similar age, body height and body mass.⁹ This is most likely a result of their ability of males to generate higher force and power output^{10,11} and their larger muscle cross sectional area and muscle fibre size than females.¹²⁻¹⁴

Gender differences in sagittal plane lumbar spine and pelvic kinematics during rowing have also been investigated in adults. McGregor et al (2008) compared pelvic and lumbar kinematics between elite male and female rowers during ergometer rowing at varying intensities and found that females displayed greater

anterior rotation of the pelvis than males.¹⁰ However, the authors did not investigate the thoracic spine and considered the lumbar spine as a single segment, despite growing evidence to support the importance of measuring regional differences in the lumbar spine.¹⁵⁻¹⁷

Gender differences in back muscle endurance performance have also been reported, with females having greater endurance.^{12,18,19} This might have implications for maintaining technique over time. For example, prolonged ergometer rowing has been associated with increased lumbar spine sagittal range of movement²⁰ and increased lumbar spine flexion relative to end range.² However, gender differences in the effect of prolonged ergometer rowing on kinematics have not yet been investigated. Therefore, it was hypothesised that differences would exist in the pelvic, regional lumbar and lower thoracic kinematics between genders at the start and end of a prolonged ergometer rowing trial. Therefore, the aim of this study was to explore pelvic, regional lumbar and lower thoracic kinematics differences between genders at the start and end of a prolonged ergometer rowing trial. Specifically, it was hypothesised that gender differences would be evident in: 1) the maximum end range flexion determined in static sitting (slouch sitting posture), 2) the thoracic, upper lumbar, lower lumbar and pelvic kinematics during a prolonged ergometer rowing trial, and 3) stroke length and duration of drive phase in the rowing cycle.

5.3 Methods

Twenty healthy adolescent rowers were recruited from private high schools and domestic rowing clubs. Participants included ten males [mean and standard deviation (SD) age 17.2 (1.4) years, height 1.85 (0.07) m and mass 78.2 (12.9) kg] and ten females [age 16.8 (0.7) years, height 1.67 (0.07) m and mass 61.0 (9.4) kg]. The inclusion criteria for this study included being aged between 14 and 19 years, rowing for a club or school at least three times per week and having completed at least one full competitive season of rowing. Rowers were excluded if they reported any musculoskeletal pain in the six weeks preceding

testing, had any past history of LBP, or had received any form of postural training/retraining. Permission to conduct the study was granted by the Institutional Human Research Ethics Committee and all subjects and their parents/guardians (where necessary) provided written informed consent (see appendix D, H, I and J).

Data Collection

Participants' pelvic, regional lower lumbar and lower thoracic kinematics were recorded using the 3-Space Fastrak™ system at a rate of 25Hz (Polhemus Navigation Science Division, Kaiser Aerospace, Vermont). For this purpose, four electromagnetic sensors were secured onto the participants' skin overlying the spinous processes of S2, L3, T12 and T6 using double sided tape and Fixomull®. The Fastrak system has been reported to be valid and reliable, reporting average errors of less than 0.2°. ²¹

Participants first performed a 'slouch' test to determine the angle equivalent to their end of range position into seated trunk flexion. This test required participants to sit on a height adjustable stool, with their thighs parallel to the floor, knees flexed 90°, their feet shoulder width apart, and their arms crossed in front of their chest. ¹⁵ Participants were then asked to 'slouch as far down as possible' while maintaining the shoulders and hips vertically aligned. They were instructed to hold this position for 5 seconds. This process was repeated three times.

Participants then completed a warm up of 5-10 minutes of sub-maximal ergometer rowing. The ergometer used in this study was a modified Concept II ergometer, so as not to interfere with Fastrak recording, as previously detailed. ²² During rowing trials the source of the Fastrak™ device was firmly secured on a rigid wooden structure attached to the rear of the sliding seat of the ergometer. ²² The Fastrak's source was positioned so that its anterior-posterior axis was orientated as close as possible to vertical. For the purpose of determining stroke

length and actual stroke rate, a rotary encoder was connected to the flywheel of the rowing ergometer. At the start of every testing session a stroke length to voltage calibration was conducted. The rotary encoder was synchronised with the Fastrak™ device through an AD board linked to a customised LabVIEW software program (Version 8.6.1, National Instruments, Texas, USA).

During the rowing trial, participants were requested to row at 22 strokes per minute, at a rating of perceived exertion (RPE) of 17/20 for a period of 20 minutes (appendix K). The RPE was collected at the beginning of every minute during the rowing trial and at the end of the 20-minute ergometer trial. RPE is considered a valid and reliable measure of exercise intensity²³ and has been used in other sport-related investigations.^{24,25} The length and stroke rate of the rowing trial was decided upon after consultation with a group of coaches (of these athletes) who indicated 20-minute ergometer sessions were part of their normal off-water rowing training. Kinematic data were collected during the last 15 seconds of the 1st and 20th minutes. During this time, at least five complete rowing cycles were collected. The drive phase of the middle three trials was used for analysis.

Data Analysis

All outputs derived from the 3-Space Fastrak™ were converted from an azimuth, elevation and roll (ZYX) ordered sequence of rotations to a sequence of elevation, azimuth and roll via matrix algebra procedures²⁶ using customized LabVIEW software (Version 8.6.1, National Instruments, Texas, USA). In this study, only the elevation plane was necessary to calculate the following four trunk and pelvis sagittal plane angles.¹⁵ Pelvis Angle (PA) - angle of the S2 sensor relative to the vertical axis of the electromagnetic source); Lower Lumbar Angle (LLA) - angle of the L3 sensor relative to the S2 sensor; Upper Lumbar Angle (ULA) - angle of the T12 sensor relative to the L3 sensor and Lower Thoracic Angle (LTA) - angle of the T6 sensor relative to the T12 sensor.

All drive phase data were time normalised (0-100%) using cubic spline interpolation and the length of the ergometer chain to define both the beginning of the drive (0%) and end of drive phase (100%). The drive phase during ergometer rowing, is defined from the point of maximum forward reach (when the chain length is shortest), until the point of maximum backwards lean (when the chain length is longest). From this information, stroke length and the proportion of the stroke in the drive phase were also determined.

There were two distinct types of angles reported in this study, the uncorrected raw angles and slouch corrected angles. For the raw angles, 0° reflected a vertically orientated trunk position, positive values indicated flexion (anterior pelvic tilt in the case of the pelvis), while negative values indicated extension (posterior pelvic tilt in the case of the pelvis).¹⁵ For slouch corrected angles, 0° reflected the participant's maximum slouch sitting position, therefore positive angles represent flexing (anterior pelvic tilt) beyond the maximum slouch sitting posture and negative angles represent extension (posterior pelvic tilt) from the maximum slouch sitting posture.

The maximum PA, LLA, ULA and LTA angles were averaged over the three slouch sitting trials. For the rowing trials the maximum and minimum of each angle was extracted in order to calculate the range. These, along with the mean of each of the angles, were averaged across each of the three trials at both the 1st and 20th minutes.

Statistical Analysis

Four sets of statistical analyses were performed. Firstly, intra-class correlation coefficients (ICC_{3,1}) were used to determine the within subject reliability of each subject's kinematic data, percentage of cycle in the drive phase and stroke length across the three completed cycles collected at the end of the 1st and 20th minutes. Secondly, an independent t-test was used to compare the angles during the slouch sitting trial between genders to determine if the PA, LLA, ULA

and LTA end range flexion mobility was different between genders. This was followed by an independent linear mixed effects model to compare the average raw and slouch corrected angles (mean and range) between adolescent male and adolescent female rowers between the 1st and 20th minute. Post hoc comparisons were used to delineate the independent effect of gender and time on kinematics. Interaction between gender and time were examined, and if non-significant, comparisons between genders during the 1st and 20th minutes were performed using pooled data (i.e. 1st and 20th minute for the gender comparison, and males and females for the time comparison). Finally, two-way ANOVA were used to compare differences between the average drive duration, stroke rate and stroke length between adolescent male and adolescent female rowers between the 1st and 20th minute. A further two-way ANOVA with covariates was used to compare stroke length adjusted for height and weight. Interaction between gender and time were also examined as stated above such that gender comparisons could be made between the 1st and 20th minutes. Confidence intervals (95% confidence intervals) for spatiotemporal kinematics were also conducted. All statistical procedures were conducted using SPSSV19.0 and the level of significance was set at $p < 0.05$.

5.4 Results

Intra-class correlation coefficients revealed good to excellent between stroke reliability for both spatial and temporal kinematics including stroke rate (ICC range = 0.989 to 0.998), PA, LLA, ULA and LTA kinematics (ICC range = 0.679 to 0.998) and percentage of stroke in drive phase (ICC range = 0.935 to 0.977). Therefore, data for the three strokes at each time period were averaged for each participant.

No differences were found in the maximum slouch angles between genders in the PA, LLA and ULA. However, males demonstrated significantly greater LTA end range flexion when compared to females (Table 5.1).

Table 5.1 – Differences in slouch sitting angles between genders

Angles	Males	Females	Differences	P-value	95% CI
PA	-3.5° (14.9)	3.5° (12.7)	7.0°	.319	-21.4, 7.4
LLA	4.5° (7.9)	-0.1° (12.8)	4.6°	.369	-6.0, 15.3
ULA	7.4° (6.7)	8.6° (8.1)	1.2°	.733	-8.7, 6.3
LTA	20.1° (8.5)	3.7° (9.8)	16.4°	.002*	7.3, 25.7

The analysis of all raw and slouch corrected spatial kinematic data revealed some differences between genders and over time. These results are presented in Table 5.2 and Figure 5.1. The analysis of raw PA revealed males typically postured their pelvis in more posterior tilt throughout the drive phase than females. Furthermore, rowers in both genders became more posteriorly tilted in the pelvis (9.5°) after 20 minutes of rowing. The mean LLA revealed no differences between-gender or over time in the raw angles. The analysis of the mean raw ULA revealed that there were no statistically significant differences between genders, but a significant increase in ULA flexion over time for both genders was observed (mean difference 4.0°). The analysis of the mean raw LTA revealed that males postured their LTA significantly more flexed than females in the raw angles (mean difference 8.3°), and rowers of both genders also postured their LTA significantly more flexed in the 20th minute compared to the 1st minute (mean difference 3.5°) (Table 5.2 and Figure 5.1). The analysis of all slouch corrected angles (PA, LLA, ULA and LTA normalised to each participant's maximum slouch position) revealed no significance difference between genders or over time.

No significant differences were found in stroke rate between genders over time (difference, 0.4spm; 95% CI: -0.996, 1.597; $p=0.547$). However, the results indicated a trend for males to have greater stroke lengths over time than females (difference, 0.1m; 95% CI: -0.17, -0.02; $p=0.056$), albeit not less than 0.05m (difference, 0.05m, 95% CI: -0.052, 0.160; $p=0.297$). These differences in stroke lengths were reduced when adjusted for mass (difference, 0.02m, 95% CI: -0.113, 0.076; $p=0.685$). Males were found to spend a significantly smaller

proportion of time of their stroke cycle in the drive phase than females (difference, 4.6%; 95% CI: 2.0, 7.0; $p=0.001$). No differences were detected in the proportion of the stroke spent in the drive phase between the 1st minute (39.0%) and the 20th minute (40.2%) in both genders (difference 1.2%; 95% CI: -2.5, 0.1; $p=0.06$).

5.5 Discussion

This study demonstrated significant and consistent gender differences in PA and LTA during rowing. Adolescent male athletes rowed with their pelvis significantly more posteriorly tilted than adolescent female rowers, which corroborates prior evidence in elite adult rowers where elite female rowers rowed with their pelvis in greater anterior rotation than their male counterparts.¹⁰ The lack of differences in the LLA and ULA were consistent with previous reports, irrespective of the fact that this study analysed regional lumbar kinematics as compared to lumbar kinematics as a whole.¹⁰ The results of the LTA demonstrate that males typically rowed with their lower thorax significantly more flexed than females, and this was consistent throughout the drive phase. The increased LTA flexion observed in males during rowing was consistent with their increased LTA flexion observed during slouch sitting (Table 5.1). The reduced degree of LTA flexion observed in females in slouch sitting may explain why female rowers trended to flex further beyond end of range (as defined by maximum slouch sitting) compared to males while rowing. This may represent a potential compensation for a lack of available flexion range in the LTA to allow for maximal forward reach during rowing (Figure 5.1).

Table 5.2 - Gender and time comparison of trunk and pelvic kinematics during drive phase

Angles	Gender	1 st min	20 th min	Gender Comparison			Time Comparison		
				M _(difference)	P-value	95% CI	M _(difference)	P-value	95% CI
Raw Angles									
PA	M	-22.3° (17.2)	-32.2° (16.2)	7.4°	<i>P</i> = .041*	0.3°, 14.4°	9.5°	<i>P</i> < .001*	4.7°, 14.4°
	F	-12.7° (15.6)	-21.8° (17.6)						
LLA	M	3.0° (9.6)	1.9° (7.5)	2.5°	<i>P</i> = .330	-2.6°, 7.6°	-2.2°	<i>P</i> = .330	-6.0°, 1.6°
	F	-0.4° (13.2)	5.0° (11.3)						
ULA	M	4.5° (8.9)	8.9° (10.0)	-1.9°	<i>P</i> = .429	-6.5°, 2.8°	-4.0°	<i>P</i> = .026*	-3.0°, 2.6°
	F	6.5° (9.7)	9.9° (10.9)						
LTA	M	16.7° (11.6)	19.6° (12.8)	-8.3°	<i>P</i> = .002*	-13.4°, -3.2°	-3.5°	<i>P</i> = .039*	-6.8°, -0.2°
	F	4.7° (7.8)	8.8° (7.3)						
Slouch Corrected Angles									
PA	M	-17.6° (17.3)	-20.7° (16.1)	2.8°	<i>P</i> = .557	-6.7°, 12.3°	2.4°	<i>P</i> = .557	-3.6°, 8.4°
	F	-13.3° (17.8)	-14.9° (22.8)						
LLA	M	-1.8° (10.6)	-1.4° (10.2)	5.0°	<i>P</i> = .074	-0.5°, 10.6°	-1.6°	<i>P</i> = .463	-5.8°, 2.7°
	F	0.9° (12.6)	3.7° (13.5)						
ULA	M	-4.6° (7.3)	-6.2° (10.5)	2.1°	<i>P</i> = .184	-1.0°, 5.2°	0.2°	<i>P</i> = .874	-2.6°, 3.0°
	F	-0.2° (7.2)	1.0° (10.1)						
LTA	M	0.2° (12.2)	8.0° (25.4)	1.3°	<i>P</i> = .792	-8.6°, 11.1°	-3.7°	<i>P</i> = .358	-11.7°, 4.3°
	F	2.3° (10.0)	1.9° (13.4)						

* denotes statistical significant differences (p<0.05)

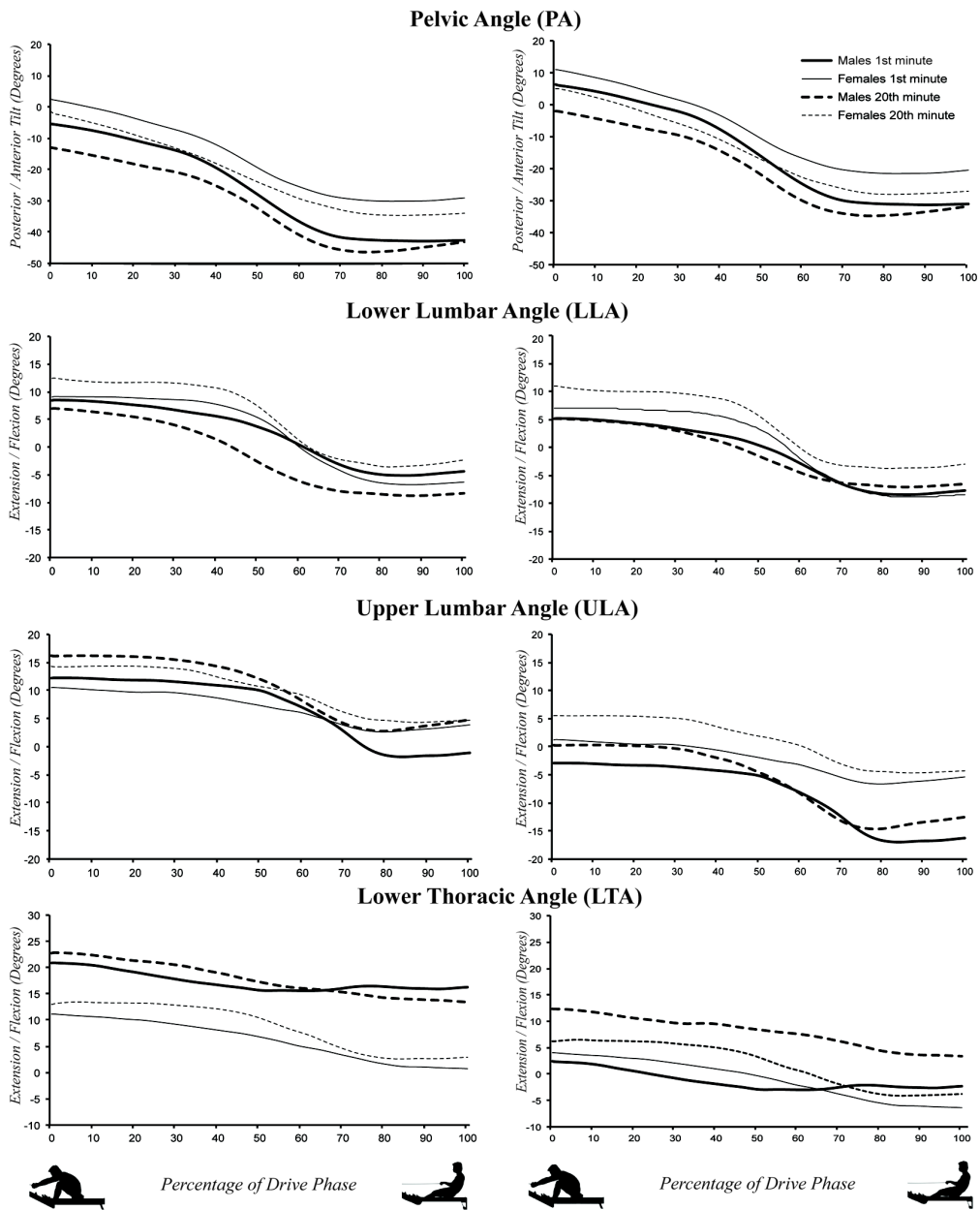

Figure 5.1 - Raw (left) and slouch corrected (right) angles of the PA, LLA, ULA and LTA during the drive phase of the 1st and 20th minute of a rowing stroke for males and females during ergometer trial

No gender differences were detected in the rowing kinematics when normalised to each rowers maximum slouch position. However, both genders were reported to move beyond their pre-defined static end of range in their PA, LLA and ULA during the first half of the drive phase of rowing. This might have injury implications; with end range strain previously proposed as a mechanism for LBP.²⁷ Whether this finding is related to the high prevalence of LBP in rowing is the focus of future research.

Although the analysis of PA, LLA, ULA and LTA over time did not indicate any gender differences, it did reveal that adolescent rowers demonstrated greater posterior pelvic tilt, and ULA and LTA flexion, between the 1st to the 20th minute. This supports previous research, which demonstrated an increase in spinal flexion over time in adult rowers.^{20,28} The average self-reported RPE was very high throughout the task²³ suggesting that the 20-minute row task was perceived by this cohort as difficult. There are a number of potential mechanisms responsible for this change in spinal flexion over time, including tissue creep, fatigue, and familiarity.

The temporal comparison revealed that while rowing at the same stroke rate, males had a significantly shorter drive phase (37.3% of a stroke) than females (41.9%). This finding is consistent with previous research in elite adult athletes where female rowers demonstrated a longer drive phase than males.¹⁰ This difference is likely related to males having greater strength^{12,29} and larger muscle cross sectional area and larger muscle fibre size in the trunk muscles than females.¹²⁻¹⁴ These differences are also the likely basis for male athletes known ability to generate greater peak forces than females, resulting in differences in performances.^{9,10,30}

Several explanations for differences in trunk and pelvic spatial kinematics observed between genders in rowing are possible. Firstly, gender differences in LTA flexion mobility in slouch sitting may reflect the differences in the LTA rowing spatial kinematic data. Other factors that were not measured in this study, such as gender differences in hamstring length extensibility and hip flexion mobility³¹ could potentially influence pelvic mobility in sitting.³² During

rowing, athletes repeatedly moved their pelvis from an anterior tilt position at the catch to posterior tilt in the finish, during the drive phase. Less extensible hamstring muscles and hip mobility in males may result in the pelvis being postured in more posterior tilt. Changes in trunk and pelvic kinematics over time may be due to viscoelastic creep associated with back muscle exertion, which is an increase in elasticity of soft tissues around spinal structures as a result of repetitive spinal flexion.³³⁻³⁵ Previous research has also shown a change in trunk kinematics during repetitive lifting tasks.³⁶ However, further evidence in rowing is required to verify the reasons for the differences between genders and over time identified in this study.

There are several possible implications from the results of this study. Firstly, the differences in pelvic kinematics between adolescent males and females are consistent with those found in adults and this may indicate a consistent rowing technique despite the difference in age and experience.¹⁰ Secondly, the finding that males typically demonstrated greater LTA flexion and posterior pelvic tilt than females may reflect different biomechanical stresses placed through the spine during ergometer rowing. Thirdly, the finding that both males and females posture their LLA and ULA beyond full range of flexion during the drive phase of rowing (although there was a trend for this pattern to be accentuated in females) suggests this may be normal in pain free rowers. Future studies are required to determine whether this phenomena has implications for end range tissue tolerance and strain. Finally, the fact that the ULA and LTA moved further into flexion with time during prolonged ergometer rowing may also have implications for tissue strain during repeated movement tasks.

We acknowledge potential study limitations. Work rate was standardised between gender using RPE in preference of mechanical power output calculated by the ergometer as RPE was more commonly used to measure work rate in this cohort of rowers and coaches. To ensure consistency in the trials, the RPE collected at the end of the 20-minute ergometer trial was used to ensure the rowers were rowing at a very high output. Only drive phase kinematics were analysed as the loaded drive phase is known to be when

peak forces and moments are generated and therefore the focus of previous performance and clinical rowing research.^{1,10,30} Furthermore age range and the impact of growth spurts and puberty status could also affect results of the study. In spite of these limitations the results are in broad agreement with previous adult rowing research suggesting that patterns observed in adults are largely reflected in adolescents. Future studies could consider examining subjects with a wider age range, and varying levels of rowing experience and using different rowing intensities and speed. Future research could also include recording of hamstring and hip joint flexibility as well as trunk and hip muscle activity to determine their influence on the gender differences observed.

In conclusion, there are consistent gender differences in pelvis and lower thoracic kinematics between adolescent rowers with male rowers demonstrating greater posterior pelvic tilt and lower thoracic flexion. There are also kinematic changes over time, with the pelvis, upper lumbar and lower thoracic trunk kinematics moving closer to end of range flexion (posterior pelvic tilt) over time for both genders. The results of this study provide evidence that coaching techniques should take gender differences into consideration. These findings may have implications for coaching practices, although whether they are related to patterns of tissue strain and injury prevalent in rowers needs to be further investigated.

5.6 Acknowledgement

The authors would like to acknowledge the School of Physiotherapy at Curtin University for providing staff funding, research personnel and equipment for this project.

5.7 References

1. Lamb DH. A kinematic comparison of ergometer and on-water rowing. *The American Journal of Sports Medicine*. 1989;17(3):367-373.
2. Caldwell JS, McNair PJ, Williams M. The effects of repetitive motion on lumbar flexion and erector spinae muscle activity in rowers. *Clinical Biomechanics*. 2003;18(8):704-711.
3. Hickey GJ, Fricker PA, McDonald WA. Injuries to elite rowers over a 10-yr period. *Medicine & Science in Sports & Exercise*. 1997;29(12):1567-1572.
4. Perich D. *Low back pain in schoolgirl rowers: prevalence, bio-psychosocial factors and prevention*. Perth: School of Exercise, Biomedical and Health Sciences, Edith Cowan University; 2010.
5. Wilson F, Gissane C, Gormley J, Simms C. A 12-month prospective cohort study of injury in international rowers. *British Journal of Sports Medicine*. 2010;44(3):207-214.
6. Teitz CC, O'Kane J, Lind B, Hannafin JA. Back pain in intercollegiate rowers. *The American Journal of Sports Medicine* 2002;30(5):674-679.
7. Perich D, Burnett A, O'Sullivan F, Perkins C. Low back pain in adolescent female rowers: A multi-dimensional intervention study. *Knee Surgery, Sports Traumatology and Arthroscopy*. 2011;19(1):20-28.
8. Seiler SK, Spirduso WW, Martin JC. Gender differences in rowing performance and power with aging. *Medicine & Science in Sports & Exercise*. 1998;30(1):121-127.
9. Yoshiga CC, Higuchi M. Rowing performance of female and male rowers. *Scandinavian Journal of Medicine & Science in Sports*. 2003;13(5):317-321.
10. McGregor AH, Patankar ZS, Bull AMJ. Do men and women row differently? A spinal kinematic and force perspective. *Proceedings of the Institution of Mechanical Engineers. Part P, Journal of sports engineering and technology*. 2008;222(2):77-83.

11. Stefani RT. The relative power output and relative lean body mass of world and Olympic male and female champions with implications for gender equity. *Journal of Sports Sciences*. 2006;24(12):1329-1339.
12. Mannion AF, Dumas GA, Cooper RG, Espinosa FJ, Faris MW. Muscle fibre size and type distribution in thoracic and lumbar regions of erector spinae in healthy subjects without low back pain: normal values and sex differences. *Journal of Anatomy*. 1997;190(4):505-513.
13. Biering-Sorensen F. Physical measurements as risk indicators for low-back trouble over a one-year period. *Spine*. 1984;9(2):106-119.
14. McGill SM, Childs A, Liebenson C. Endurance times for low back stabilization exercises: clinical targets for testing and training from a normal database. *Archives of Physical Medicine and Rehabilitation*. 1999;80(8):941-944.
15. Dankaerts W, O'Sullivan P, Burnett A, Straker L. Differences in sitting postures are associated with nonspecific chronic low back pain disorders when patients are subclassified. *Spine*. 2006;31(6):698-704.
16. Mitchell T, O'Sullivan PB, Burnett AF, Straker L, Smith A. Regional differences in lumbar spinal posture and the influence of low back pain. *BMC Musculoskeletal Disorders*. 2008;9:152-162.
17. Gill KP, Bennett SJ, Savelsbergh GJ, van Dieen JH. Regional changes in spine posture at lift onset with changes in lift distance and lift style. *Spine*. Jul 1 2007;32(15):1599-1604.
18. Kankaanpaa M, Laaksonen D, Taimela S, Kokko SM, Airaksinen O, Hanninen O. Age, sex, and body mass index as determinants of back and hip extensor fatigue in the isometric Sorensen back endurance test. *Archives of Physical Medicine and Rehabilitation*. 1998;79(9):1069-1075.
19. Smith AJ, O'Sullivan PB, Campbell AC, Straker LM. The relationship between back muscle endurance and physical, lifestyle, and psychological factors in adolescents. *Journal of Orthopaedic & Sports Physical Therapy*. 2010;40(8):517-523.
20. Holt PJ, Bull AMJ, Cashman PM, McGregor AH. Kinematics of spinal motion during prolonged rowing. *International Journal of Sports Medicine*. 2003;24(8):597-602.

21. Pearcy MJ, Hindle RJ. New method for the on-invasive three-dimensional measurement of human back movement. *Clinical Biomechanics*. 1989;4(2):73-79.
22. Ng L, Burnett A, O'Sullivan P, Campbell A. Caution: The use of an electromagnetic device to measure trunk kinematics on rowing ergometers. *Sports Biomechanics*. 2009;8(3):255-259.
23. Borg G. Psychophysical bases of perceived exertion. *Medicine and Science in Sports and Exercise*. 1982;14(5):377-381.
24. Foster C, Florhaug JA, Franklin J, et al. A new approach to monitoring exercise testing. *Journal of Strength Conditioning Research*. 2001;15(1):109-115.
25. Garcin M, Vautier J, Vandewalle H, Monod H. Ratings of perceived exertion (RPE) as an index of aerobic endurance during local and general exercises. *Ergonomics*. 1998;41(8):1105-1114.
26. Burnett AF, Barrett CJ, Marshall RN, Elliott BC, Day RE. Three-dimensional measurement of lumbar spine kinematics for fast bowlers in cricket. *Clinical Biomechanics*. 1998;13(8):574-583.
27. Solomonow M. Ligaments: a source of work-related musculoskeletal disorders. *Journal of Electromyography and Kinesiology*. 2004;14(1):49-60.
28. Wilson F, Gormley J. Kinematics of lumbar spine motion in rowing during a fatiguing protocol: A comparison of ergometer and boat rowing. *British Journal of Sports Medicine*. 2011;45(4):383.
29. Miller AEJ, MacDougall JD, Tarnopolsky MA, Sale DG. Gender differences in strength and muscle fiber characteristics. *European Journal of Applied Physiology and Occupational Physiology*. 1993;66(3):254-262.
30. Hosea T, Bolard A, McCarthy K. Rowing injuries. *Post Graduate Advances in Sports Medicine*. 1989:University of Pennsylvania: Forum Medicum Inc.
31. Gajdosik RL, Hatcher CK, Whitsell S. Influence of short hamstring muscles on the pelvis and lumbar spine in standing and during the toe-touch test. *Clinical Biomechanics*. 1992;7(1):38-42.

32. Bridger RS, Orkin D, Henneberg M. A quantitative investigation of lumbar and pelvic postures in standing and sitting: Interrelationships with body position and hip muscle length. *International Journal of Industrial Ergonomics*. 1992;9(3):235-244.
33. Solomonow M, Baratta RV, Zhou BH, Burger E, Zieske A, Gedalia A. Muscular dysfunction elicited by creep of lumbar viscoelastic tissue. *Journal of Electromyography and Kinesiology*. 2003;13(4):381-396.
34. Keyserling WM, Sudarsan SP, Martin BJ, Haig AJ, Armstrong TJ. Effects of low back disability status on lower back discomfort during sustained and cyclical trunk flexion. *Ergonomics*. 2005;48(3):219-233.
35. Solomonow M, Zhou B, Baratta RV, Yun L, Harris M. Biomechanics of increased exposure to lumbar injury caused by cyclic loading: part 1. loss of reflexive muscular stabilization. *Spine*. 1999;24(23):2426-2434.
36. Sparto PJ, Parnianpour M, Reinsel TE, Simon S. The effect of fatigue on multijoint kinematics and load sharing during a repetitive lifting test. *Spine*. 1997;22(22):2647-2654.

Chapter 6 - Study 4

Spinal kinematics of adolescent male rowers with back pain in comparison to matched controls during ergometer rowing

Authors: Leo Ng, Peter O'Sullivan, Angus Burnett, Anne Smith,
Amity Campbell

The specific aim for Study 4 was:

- To compare the regional lumbar kinematics of adolescent male rowers with and without low back pain.

Study 4 has been formatted for the *Journal of Orthopaedic & Sports Physical Therapy* guidelines.

6.1 Abstract

Study Design: Laboratory Observational study

Objectives: To compare regional lumbar kinematics between adolescent male rowers with and without low back pain (LBP).

Background: There is a high prevalence of LBP in adolescent rowers. Mechanical factors such as spinal kinematics during ergometer rowing were suggested to provoke LBP in this cohort. No studies have investigated regional lumbar kinematics during ergometer rowing in rowers experiencing LBP.

Methods: Lumbar kinematics of 20 adolescent male rowers, 10 reporting moderate levels of LBP at the time of the study and 10 with no history of LBP, were collected during a 15-minute ergometer trial using an electromagnetic tracking system (3-Space Fastrak™). Self reported LBP and regional lumbar kinematics in the sagittal plane of the upper and lower lumbar spines were compared between the two groups.

Results: Rowers with LBP reported a gradual increase in LBP intensity during the 15-minute ergometer trial. Although no significant differences were detected in mean upper or lower lumbar angles between rowers with and without LBP, rowers with pain had greater variability in upper and lower lumbar angles over the 15-minute ergometer trial than rowers with no pain. Rowers with LBP also positioned their upper lumbar spine near end range flexion for a greater proportion of the drive phase.

Conclusion: These findings suggest that adolescent male rowers with LBP reported an increasing level of pain during ergometer rowing. Differences in lumbar kinematics also exist in the amount of time the upper lumbar spine was in sustained flexion loading.

Level of Evidence: Level 3

Keywords: rowing, low back pain, adolescent

6.2 Introduction

Low back pain (LBP) is a common condition experienced by rowers at all levels of competition.^{3,16,19,52} Male rowers have been shown to have a higher incidence of LBP than female rowers at the elite senior¹⁶ and elite junior levels.³⁹ Junior male rowers reported an incidence rate of 34.4% compared to 29.9% in junior female rowers during the 2007 Junior World Rowing Championship, although no statistical analysis was used to determine whether the difference was significant.³⁹ Research has also found a higher prevalence of LBP in adolescent female rowers when compared to an age-matched non-rowing control group suggesting there are rowing-specific factors that are associated with pain.³²

Mechanical factors such as long on-water rowing time in training sessions, repetitive lifting of the rowing shell, ergometer rowing,^{31,47} and motor control of the spine (spinal kinematics)^{4,7,22} have been suggested to provoke LBP in rowers. To date, it is not known whether the vulnerability to pain is associated with individual factors such as lumbar kinematics during ergometer rowing and tissue pain thresholds to loading. Understanding LBP mechanisms in high risk adolescent sporting populations such as rowing is important, as this is the age where most rowers take up the sport and LBP in adolescence is a known predictor of LBP in adulthood.¹⁵ This has clear implications to both individual rowers and the community.

It has been suggested that the lumbar flexion and the repetitive nature of rowing may increase lumbar excursion during rowing, which has been linked to back injury.^{18,35,53} Both cadaveric studies and *in-vivo* studies have demonstrated that repetitive flexion,^{40,41} sustained flexion,^{40,42} loaded flexion¹⁸ and end-range flexion^{6,13,25,29} may cause soft tissue strain to the lumbar spine which could result in pain. Previous research has identified end-range spinal flexion in sitting to be related to LBP in both sporting^{6,22,48} and non-sporting populations.^{11,26,29}

Several studies have reported spinal kinematics during rowing using healthy populations and speculated a link with spinal movement and LBP.^{4,7,33,53}

These reports have shown that rowers frequently posture their spine near or beyond end-range of spinal flexion with the magnitude of lumbar flexion increasing over time which may have injury implications.^{7,17,24,33,53}

However, none of these investigations considered two separate lumbar regions (upper and lower) in a painful population, which is now recognised as the most appropriate method of quantifying lumbar regional kinematics.^{11,14,21,25,50} Individuals with LBP are shown to control their upper and lower lumbar spine differently to healthy subjects.^{11,25} Furthermore, cyclists with LBP have reported to posture their lower lumbar spine, but not upper lumbar spine, closer to end range flexion as compared to a healthy control group.^{6,48} At present, there is limited literature that has examined regional spinal movement during rowing despite evidence to support differences in regional lumbar spinal movement are related to LBP in the general population.^{11,14,21,24,50}

Therefore, the aims of this study were to; investigate whether there is an increase in LBP intensity in rowers with LBP, and to investigate differences in lumbar kinematics between rowers with and without LBP, during a 15-minute rowing ergometer trial. Specifically, we hypothesised that

1. Pain intensity levels for rowers with LBP would increase over the course of a 15-minute rowing ergometer trial.
2. Rowers with LBP would posture their upper and lower lumbar spine in more flexion than rowers without LBP in the drive phase of ergometer rowing, becoming greater over 15 minutes of rowing.
3. Rowers with LBP would spend a greater proportion of the drive phase of the rowing stroke with their upper/lower lumbar spine near end range flexion than rowers without LBP, becoming greater over 15 minutes of rowing.

6.3 Methods

Participants

Twenty adolescent male rowers aged between 14 to 19 years, with (n=10) and without (n=10) LBP participated in this study (Table 6.1). A power calculation prior to participant recruitment suggested that 10 participants in each group would have an 80% power to detect a group difference of 10 degrees (assuming a standard deviation of 10 in both groups, repeated measures for 3 phases over 1,7 and 15th minute, and a within-subject correlation of 0.6). Participants were included if they performed rowing training for a school-rowing club or a community rowing club at least 3 times a week as well as competing in rowing regattas. Participants were defined as having LBP if their self-reported LBP was between the levels of L₁ to inferior gluteal folds and provoked by rowing with a pain intensity greater than 3/10 as indicated by a visual analogue scale (VAS) within 30 minutes of rowing training (appendix L). The characteristics of the participants including; age, height, mass, body mass index (BMI), self reported level of pain during participant recruitment (VAS) and disability as collected from the Roland Morris Disability Questionnaire (RMDQ)(appendix M)³⁷ and Patient Specific Functional Scale (PSFS)(appendix N)⁴⁴ are presented in table 6.1.

Participants in the no pain group had no history of LBP. Rowers were excluded from this study if there was a presence of specific causes of LBP such as inflammatory diseases, radicular pain or neurological signs to the lower limbs, or if they had reported any lower limb musculoskeletal injury in the 6 weeks preceding data collection. Further, participants were excluded if they received any rowing specific postural training during previous rehabilitation of their LBP, as this may have influenced their spinal kinematics during rowing, which is an outcome measure of this study. Permission to conduct the study was granted by the Institutional Human Research Ethics Committee and all subjects and their parents/guardians (where necessary) provided written informed consent/assent (appendix D, I and J).

Data Collection

Lumbar Kinematics

Regional lumbar angles in the sagittal plane during the experimental protocol were collected using the 3-Space Fastrak™ electromagnetic tracking system at 25 Hz (Polhemus Navigation Science Division, Kaiser Aerospace, Vermont). This consists of a systems electronic unit, a source and four sensors. The source emits a low frequency magnetic field that the sensors use to detect the relative three-dimensional (3D) position and orientation. The Fastrak™ system has been used in previous rowing studies,^{24,43} and has been reported to be valid and reliable in measuring joint angles reporting average errors of 0.4° on measuring trunk and pelvic kinematics on a modified rowing ergometer.²³ Three of the device's sensors were secured onto the participant's skin overlying the spinous processes of S2, L3 and T12 using double sided tape and Fixomull®.^{11,24,43} A rotary encoder was connected to the flywheel of the rowing ergometer to determine the stroke length and stroke rate. Prior to every data collection trial, stroke length was calibrated with the voltage on the rotary encoder and then synchronised with the Fastrak™ system using a customised Labview software program (Version 8.6.1, National Instruments, Texas, USA). This stroke length was used to determine the start and the end of the drive phases, stroke length is shortest at the beginning of the drive phase (catch)(figure 6.1A), and longest at the end of the drive phase (finish)(figure 6.1B). Ergometer rowing was chosen for this study, as it has been identified as an aggravating factor to LBP in adolescent rowers,³² and trunk and lower limb kinematics were reported to be similar between ergometer rowing and on-water rowing.²⁰



Figure 6.1A – Catch position during ergometer rowing

Figure 6.1B – Finish position during ergometer rowing

Participants' maximum slouch angles of the Lower Lumbar Angle (LLA) and Upper Lumbar Angle (ULA) in static sitting were collected in order to calculate the maximum static range of movement of LLA and ULA. A detailed description of this process of deriving LLA and ULA is described in the data analyses section of this paper. For this purpose, participants were instructed to sit on a height adjustable stool with a flat horizontal surface (with no back support); their feet were placed shoulder width apart and lower legs vertical to the ground; and their arms crossed in front of their chest. They were then instructed to 'slouch as far down as possible' while maintaining the shoulders directly over the hips. They were required to hold this position for 5 seconds, and this process was repeated 3 times with a 30 seconds rest between each trial. This protocol was used in a previous study by the authors.²⁴

The ergometer used in this study was a modified Concept II ergometer (with ferrous metal removed), as the presence of ferrous metal was reported to reduce the accuracy and increase variability of the Fastrak™ recording system.²³ Prior to testing participants completed a 5-10 minute warm up involving sub-maximal ergometer rowing. Participants then rowed for 15 minutes at a stroke rate of 22 strokes per minute with a rating of perceived exertion (RPE) of 17/20 (see appendix K). This protocol was designed after consultation between the research team and coaches, pilot data revealed that participants with LBP could only sustain ergometer rowing at this intensity for 15 minutes before pain became too intense to continue. Participants were advised to cease the ergometer trial if their level of pain during testing reached or exceeded the level of pain during their usual rowing training or competition. Kinematic data from three completed strokes was collected during the last 15 seconds of the 1st, 7th and 15th minutes to compare kinematics at the start, middle and end of a 15-minute sub-maximal ergometer trial.

Numeric Pain Rating Scale (NPRS):

The NPRS is an 11-point scale (0-10) to collect self-reported pain intensity, where 0 represents no pain and 10 represents maximal pain intensity.⁹ The

NPRS were collected verbally at the beginning of every minute of the ergometer trial and also at the end of the 15-minute ergometer trial.

Data Analysis

A customised LabVIEW program (Version 8.6.1, National Instruments, Texas, USA) converted all outputs derived from the 3-Space Fastrak™ to elevation, azimuth and roll via matrix algebra procedures in order to have a valid and reliable reading in flexion and extension angles (angles in the sagittal plane).⁵ From these procedures, the LLA and the ULA were derived (Figure 6.2):

- Lower Lumbar Angle (LLA): the angle of the sensor placed over the spinous process of the 3rd lumbar vertebrae (L3) relative to the sensor placed on the spinous process of the 2nd sacral vertebrae (S2) – where 0° indicates a parallel alignment between the L3 and the S2 sensor.
- Upper Lumbar Angle (ULA): the angle of the sensor placed over the spinous process of the 12th thoracic vertebrae (T12) relative to the spinous process of the 3rd lumbar vertebrae (L3) sensor – where 0° indicates a parallel alignment between the T12 and the L3 sensor.

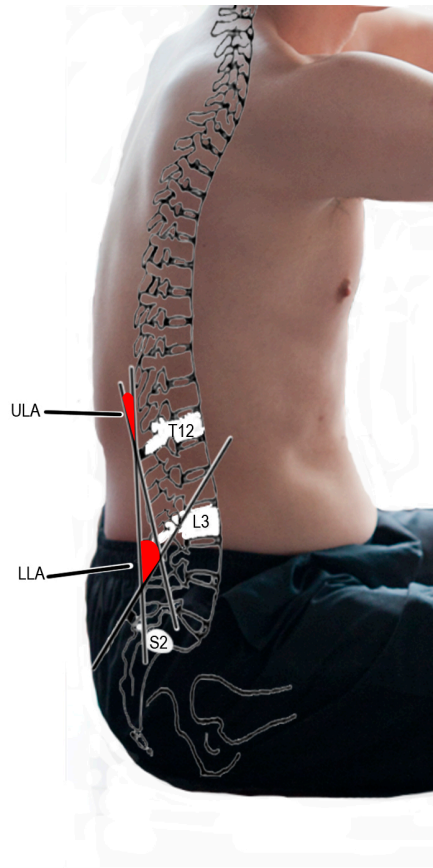

Figure 6.2 – Regional lumbar kinematics (ULA – Upper Lumbar Angle; LA – LLA – Lower Lumbar Angle)

Only sagittal plane angles and data from the drive phase were analysed similar to other rowing ergometer kinematic studies,^{7,17,33,43} given that the drive phase is when the spinal load is greatest.¹⁸ All data in the drive phase were time normalised, with 0% defined as the catch and 100% defined as finish. Near end-range flexion was defined as above 80% of the maximum slouch angle during the static sitting test.⁴⁸

Statistical Analysis

Independent t-tests were used to determine whether age, height, body mass and BMI differed between no pain and pain groups. A linear two level mixed-effects model was used to evaluate the change in NPRS scores reported at baseline and at each minute over the 15 minutes of rowing to assess the relationship between rowing and LBP intensity over time.

Flexion angle measures taken at percentiles of the drive phase from three completed strokes were averaged to produce a single flexion angle (for both ULA and LLA) for the early (0,10 and 20th percentile), mid (30-70th percentile) and late (80,90 and 100th percentile) drive phase, at the end of the 1st, 7th and 15th minute of rowing. A linear three level mixed-effects model was used to determine differences between pain and no pain groups, using the 9 repeated measures over drive phase (early/mid/late) nested in minutes (1,7 and 15). Differences in flexion angle across phase and minute were examined and estimates of group difference adjusted for these factors. To examine if the difference in flexion angles between pain and no pain groups became larger over the 15 minutes of rowing, a groupXminute interaction term was evaluated. To examine if flexion angles between pain and no pain groups were different over the early, mid and late drive phase, a groupXphase interaction term was evaluated.

To evaluate the proportion of drive phase near end range flexion, angular measures (for both ULA and LLA) were sampled at 25Hz for three completed strokes collected during the last 15 seconds of the 1st, 7th and 15th minute of ergometer rowing. These values were expressed as a percentage of maximum slouch sitting angle, and the proportion of drive phase measures for which this value exceed 80% was calculated then averaged over the three strokes at the 1st, 7th and 15th minute. A linear two-level mixed-effects model was used to determine differences between pain and no pain groups, using the 3 repeated measures at the 1st, 7th and 15th minute. Differences in proportion of drive phase near end range flexion across each minute were examined and the estimate of group difference adjusted for each minute. To examine if the difference in proportion of drive phase near end range flexion between pain and no pain groups increased over the 15 minutes of rowing, a groupXminute interaction term was evaluated. The non-parametric ranks-based Mann-Whitney test was also performed on these measures to test for group difference at the 1st, 7th and 15th minute separately to confirm findings were robust to misspecification of the linear mixed models.

Models were estimated with and without adjustment for height, weight and age to check for confounding. An absence of confounding was assumed if potential confounders were non-significant in models at $\alpha > 0.1$; in this case coefficients were estimated without adjustment for these factors.

6.4 Results

Group Differences

Rowers with pain were significantly taller and heavier than rowers with no pain but no differences were found in the age and BMI between the two groups (Table 6.1). In the pain group, NPRS scores increased significantly over the 15 minutes of rowing from 1.7 (95%CI: 1.0 to 2.3) at baseline to 7.8 at the 15th minute (95%CI: 7.10 to 8.42), with the rate of increase estimated to be 0.41 per minute (95%CI: 0.38 to 0.44, $p < .001$) (Figure 6.3). There were no statistically significant differences in the maximum slouch angles during the static sitting trial between groups, rowers in the pain group postured their LLA at 3.2° compared to 3.7° in the no pain group (95%CI: -13.2° to 12.3°, $p = 0.942$) and ULA 4.6° in the pain group compared to 2.6° in the no pain group (95%CI: -7.2° to 11.1°, $p = 0.656$).

TABLE 6.1 – Mean and standard deviation of characteristics in each group and the mean, standard error and p-value of differences between the no pain and pain group

Characteristic	No Pain (n=10)	Pain (n=10)	Mean	95% CI	P-value
Age (years)	17.2 (1.4)	16.0 (1.2)	1.2	-0.1, 2.4	.074
Height (m)	1.85 (0.08)	1.70 (0.09)	0.15	-0.2, -0.1	<.001
Weight (kg)	78.2 (12.9)	66.8 (10.8)	11.5	-22.9, 0.0	.050
BMI (kg/m ²)	23.1 (3.4)	22.8 (3.8)	0.3	-2.7, 3.4	0.818
VAS (/10)	n/a	4.6 (1.1)			
PSFS (/30)	n/a	17 (6.1)			
RMDQ (/22)	n/a	3.5 (2.1)			

BMI = Body Mass Index; VAS = Visual Analogue Scale; PSFS = Patient Specific; Scale; RMDQ = Roland Morris Disability Questionnaire.

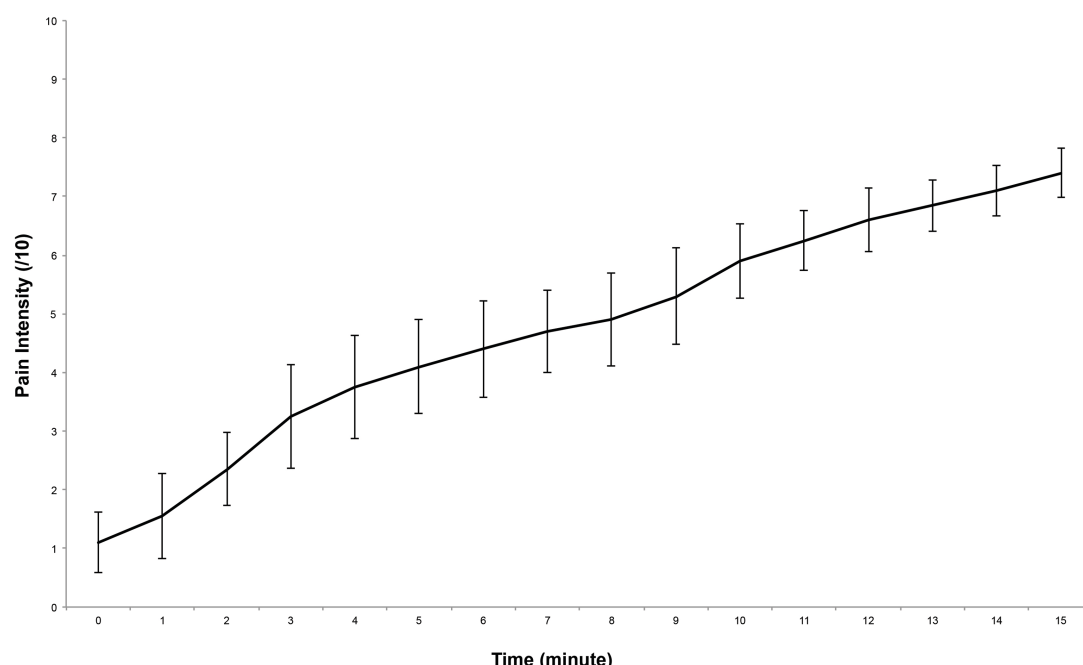

Figure 6.3 – Group mean and standard deviation of LBP intensity scores (measured by Numeric Pain Regional Scale) during the 15-minute rowing ergometer trial

Lower Lumbar Angle

Table 6.2 presents the means and standard deviations for LLA by phase, minute and pain/no pain group. Figure 6.3 presents LLA for each subject at the early, mid and late drive phase over the 1st, 7th and 15th minute separately for each pain group. Analysis using linear mixed effects model identified a significant main effect for phase (p<.001) and no evidence of

interaction between pain group and phase ($p=.821$), with flexion decreasing from early, mid to late phase similarly in both groups (Table 6.3). A significant main effect for pain group was not detected ($p=.688$), although an interaction between minute and pain group was ($p=.012$), with the pain group displaying more extension (adjusted for phase) in the 15th minute compared to the 1st minute, whereas the no pain group displayed similar LLA at all 3 time points (Table 6.3). Examination of the raw data plotted in Figure 6.4 suggests more variability in changes over minute in the pain group, with relatively large changes occurring in both directions, compared to a consistent pattern of no change in the no pain group. This was formally tested by comparing the variance of the error terms in the mixed effects model. These were significantly different, with the standard deviation for the pain group being greater [10.6° (95%CI: 9.4° to 12.8°)] than the no pain group [4.0° (95%CI: 3.4° to 4.7°)], indicating significantly greater variability in the pain group data. Adjustment for height, weight and age revealed no confounding of group differences and results are presented unadjusted for these factors to maximise precision of estimates.

Table 6.2 - Mean and standard deviation of the lower and upper lumbar angles for drive phases over 1st 7th and 15th minute, for Pain and No Pain group

Min	No Pain			Pain		
	Early Phase	Mid Phase	Late Phase	Early Phase	Mid Phase	Late Phase
Lower lumbar angle ($^\circ$)						
1	8.8 (6.7)	3.7 (7.4)	-4.2 (11.1)	9.3 (16.2)	7.7 (10.0)	3.5 (11.5)
7	8.7 (7.0)	2.9 (7.5)	-2.8 (9.8)	11.5 (9.6)	7.6 (9.6)	1.9 (10.8)
15	8.8 (7.4)	2.9 (8.3)	-3.0 (11.1)	6.9 (21.4)	-1.1 (18.1)	-8.2 (21.9)
Upper lumbar angle ($^\circ$)						
1	8.6 (7.1)	5.4 (8.0)	-4.8 (7.7)	8.2 (7.2)	5.4 (7.6)	1.2 (9.3)
7	11.2 (6.1)	6.6 (6.7)	-2.4 (8.1)	9.4 (8.4)	6.3 (11.2)	1.2 (14.0)
15	11.8 (6.3)	7.1 (6.6)	-1.8 (8.2)	9.8 (10.1)	5.5 (14.7)	0.6 (17.1)

Table 6.3 - Mixed model coefficients for lower and upper lumbar angle

		Marginal means (⁰)	β coefficient(⁰) (i.e. contrast)	95% CI	p-value
Lower lumbar angle					
Group (Pain – No Pain)					
At Minute 1:	NP	2.8			
	P	6.8	4.1	-3.8 to 12.0	.313
At Minute 7	NP	3.0			
	P	7.0	4.0	-3.9 to 12.0	.318
At Minute 15	NP	2.9			
	P	-0.8	-3.7	-11.6 to 4.2	.358
Phase (ref to Early Phase)					
	Early	9.4			
	Mid	3.9	-5.5	-7.4 to -3.6	<.001
	Late	-2.5	-11.9	-13.8 to -10.0	<.001
Minute (ref to Minute 1)					
No Pain Group	Min 1	2.8			
	Min 7	3.0	0.2	-1.8 to 2.2	.857
	Min 15	2.9	0.1	-1.9 to 2.1	.903
Pain Group	Min 1	6.8			
	Min 7	7.0	0.1	-5.4 to 5.7	.961
	Min 15	-0.8	-7.7	-13.2 to -2.1	.007
Upper lumbar angle					
Group (Pain – No Pain)					
At Phase 1	NP	10.5			
	P	9.1	-1.4	-8.0 to 5.2	.682
At Phase 2	NP	6.4			
	P	5.7	-0.6	-7.2 to 6.0	.849
At Phase 3	NP	-3.0			
	P	1.0	4.0	-2.6 to 10.6	.233
Phase (ref to Early 1)					
No Pain Group	Early	10.5			
	Mid	6.4	-4.2	-5.6 to -2.7	<.001
	Late	-3.0	-13.5	-15.0 to -12.1	<.001
Pain Group	Early (1)	9.1			
	Mid (2)	5.7	-3.4	-5.9 to -1.0	.007
	Late (3)	1.0	-8.1	-10.6 to -5.7	<.001
Minute (ref to Minute 1)					
	Min 1	3.9			
	Min 7	5.4	1.5	-1.6 to 4.6	.358
	Min 15	5.6	1.6	-1.5 to 4.7	.302

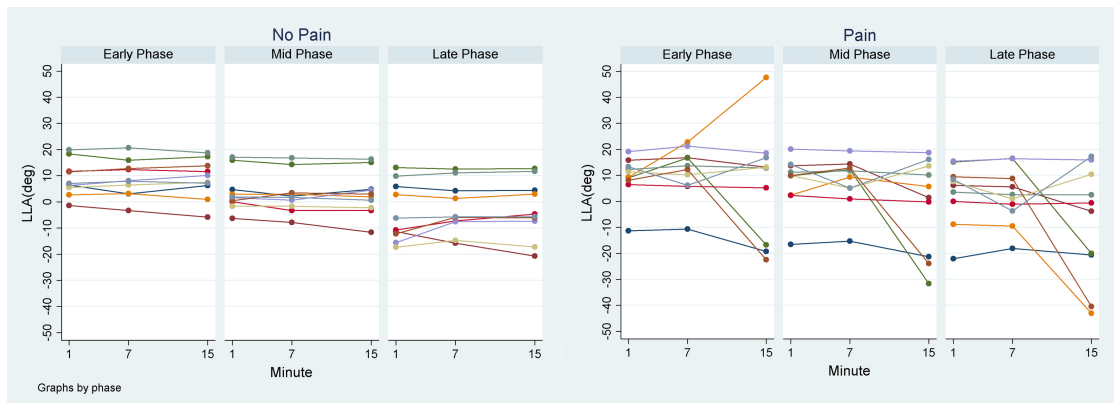

Figure 6.4 – Lower lumbar angle for each subject over the 1st, 7th and 15th minute, for the early, mid and late drive phase separately, in pain and no pain groups separately

Upper Lumbar Angle

Table 6.2 presents the means and standard deviations for ULA by phase, minute and pain/no pain group. Figure 6.5 presents ULA for each subject over the early, mid and late drive phase at the 1st, 7th and 15th minute, separately for each pain group. Analysis using linear mixed effects model identified no effect for minute ($p=.526$) and no group \times minute interaction ($p=.774$). Although there was evidence that the group difference differed by phase ($p<.001$), the estimated group difference was not statistically significant at any phase (table 6.3). The significant interaction between phase and group meant the degree of change over phase was estimated to differ by group, with a pattern of significantly more extension over early, mid and late phase evident in both groups (table 6.3), but to a significantly lesser extent in the pain group. Again, raw data plotted in figure 6.5 suggests more variability in changes over phase in the pain group, with less consistent pattern of increasing extension over the drive phase compared to the consistent pattern seen in the no pain group. This was formally tested by comparing the variance of the error terms in the mixed effects model. These were significantly different, with the standard deviation for the pain group being greater (4.9° (95%CI: 4.0° to 6.0°) than the no pain group (2.8° (95%CI: 2.4° to 3.3°)), indicating significantly greater variability in the pain group data. Adjustment for height, weight and age revealed no confounding of group

differences and results are presented unadjusted for these factors to maximise precision of estimates.

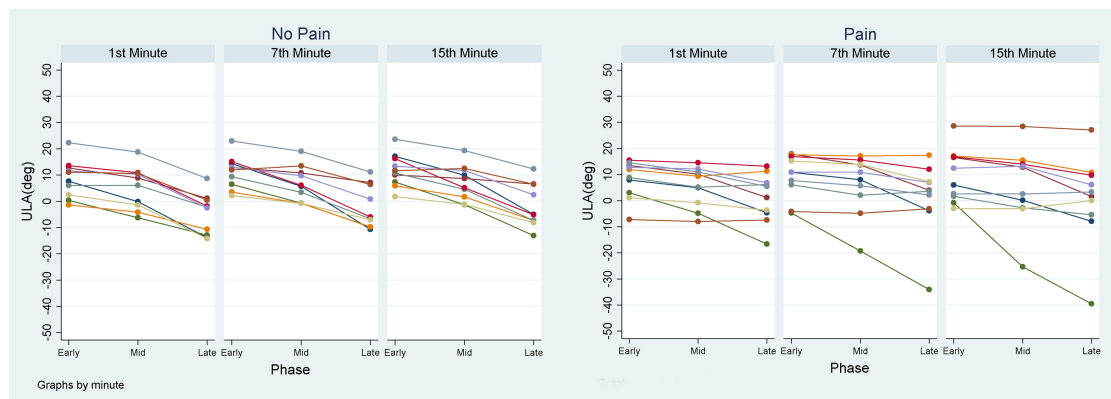

Figure 6.5 – Upper lumbar angle for each subject over the drive phase separately for 1st, 7th and 15th minute, in pain and no pain groups separately

Lower lumbar proportion of drive phase near end range flexion

Table 6.4 presents the raw means and standard deviations for the proportion of drive phase near end range LLA flexion by minute and pain/no pain groups. Figure 6.6A presents this data graphically for each subject over 1st, 7th and 15th minute, separately for each group. Analysis using linear mixed effects model detected evidence of an association between a lesser proportion of drive phase spent in flexion with increasing age and (weight-adjusted) height (Table 6.5). No effect for minute ($p=.872$) and no group \times minute interaction were observed ($p=.284$). The pain group was estimated to spend less of the proportion of drive phase in near end range than the no pain group, adjusted for minute, age, height and weight ($-.27$, 95%CI: $-.59$ to $.04$, $p=.087$, Table 6.5) but this difference was not statistically significant. The raw data plotted in Figure 6.5A displays suggests greater degree of variability in the proportion of drive phase near end range LLA flexion in the pain group, with less consistent patterns over time in the pain group. Again, this was formally tested by comparing the variance of the error terms in the mixed effects model. These were significantly different, with the standard deviation for the pain group being greater ($.31$ (95%CI: $.23$ to $.42$) than the no pain group ($.06$ (95%CI: $.04$ to $.08$), indicating significantly greater variability in the pain group data. Nonparametric analysis of this data also did not detect a difference in

proportion of drive phase in near end range LLA in the pain group at the 1st, 7th or 15th minute (Mann Whitney test, $p = .341, .272$ and $.702$ respectively).

Table 6.4 - Percentage of drive phase in greater than 80% of flexion range for Lower and upper angle, for Pain and No Pain group

Minute	Lower Lumbar Angle (%)		Upper Lumbar Angle (%)	
	No Pain	Pain	No Pain	Pain
1	0.56 (0.34)	0.69 (0.36)	0.45 (0.33)	0.68 (0.36)
7	0.58 (0.34)	0.62 (0.38)	0.48 (0.17)	0.77 (0.17)
15	0.58 (0.34)	0.49 (0.46)	0.48 (0.16)	0.52 (0.38)

Upper lumbar proportion of drive phase near end range flexion

Table 6.5 presents the raw means and standard deviations for the proportion of drive phase near end range ULA flexion by minute and pain/no pain groups. Figure 6.6B presents this data graphically for each subject over the 1st, 7th and 15th minute, separately for each pain group. Analysis using linear mixed effects model detected no evidence of an association between a lesser proportion of drive phase spent in ULA flexion with increasing age ($\beta = .00$, 95%CI: $-.06$ to $.06$, $p = .974$) and (weight-adjusted) height ($\beta = -.01$, 95%CI: $-.02$ to $.01$, $p = .144$), unlike results for LLA, and models were estimated unadjusted for these factors. No effect for minute ($p = .548$) and no groupXminute interaction were observed ($p = .226$). The pain group was estimated to spend a greater proportion of drive phase in near end range ULA flexion than the no pain group ($.19$, 95%CI: $.03$ to $.35$, $p = .021$, Table 6.5). The raw data plotted in Figure 6.6B suggests a greater degree of variability generally in the proportion of drive phase near end range for ULA flexion versus LLA, with more inconsistent patterns over time in both groups for ULA than those for LLA depicted in figure 6.5B. The standard deviation of the residuals for the pain group ($.29$ (95%CI: $.21$ to $.39$) were comparable to the no pain group ($.19$ (95%CI: $.14$ to $.26$)). Nonparametric analysis of this data confirmed a significantly greater proportion of drive phase in near end range ULA in the pain group at the 7th minute (Mann Whitney test, $p = .002$) but not the 1st ($p = .160$) or 15th minute ($p = .650$).

Table 6.5 - Mixed model results for proportion of drive phase in >80% lower and upper lumbar end range flexion

		Marginal means (⁰)	β coefficient (⁰) (contrast)	95% CI	p-value
Lower Lumbar Angle					
Group (Pain – No Pain)					
	NP	.72			
	P	.45	-.27	-.59 to .04	.087
Minute (ref to Minute 1)					
	Min 1	.58			
	Min 7	.59	.01	-.04 to .06	.647
	Min 15	.59	.01	-.04 to .06	.657
Covariates					
Age (yrs)	16.6 ^a	.59	-.10 ^b	-.20 to -.01	.036
Height (cm)	177.6 ^a	.59	-.02 ^b	-.04 to -.00	.030
Weight (Kg)	72.5 ^a	.59	.01 ^b	.00 to .02	.080
Upper Lumbar Angle					
Group (Pain – No Pain)					
	NP	.47			
	P	.66	.19	.03 to .35	.021
Minute (ref to Minute 1)					
	Min 1	.56			
	Min 7	.60	.04	-.09 to .19	.509
	Min 15	.53	-.03	-.17 to .11	.668

^amean of covariate in the sample

^b β coefficient represents the expected change in proportion of drive phase spent in >80% end range flexion with each increase of one unit in the covariate

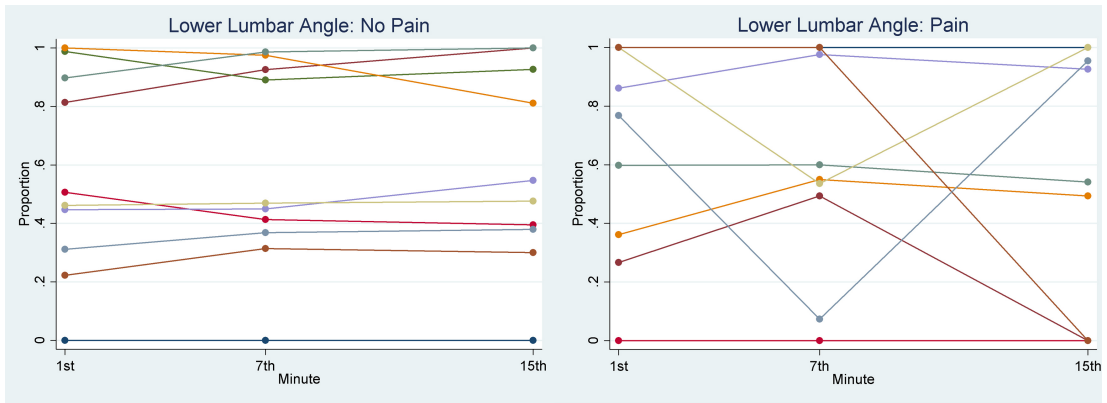

Figure 6A

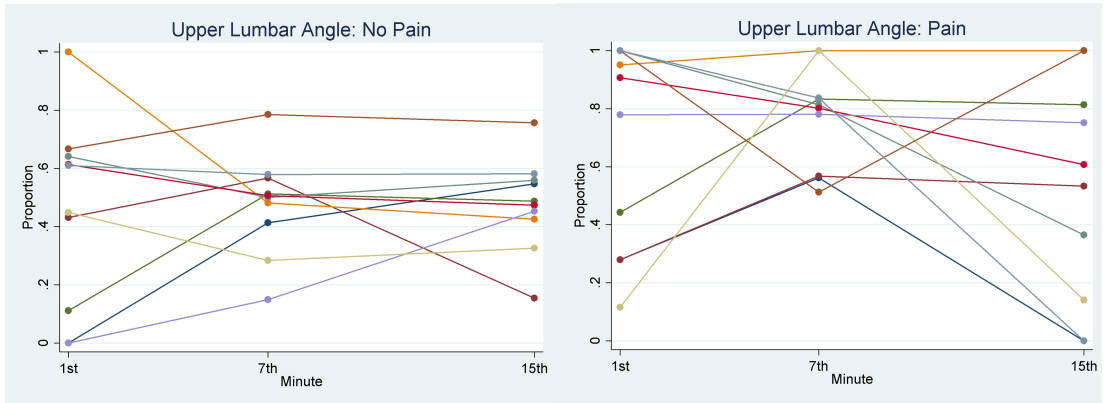

Figure 6B

Figure 6.6A: Proportion of drive phase lower lumbar angle in greater than 80% flexion over 1st, 7th and 15th minute, in pain and no pain groups separately

Figure 6.6B: Proportion of drive phase upper lumbar angle in greater than 80% flexion over 1st, 7th and 15th minute, in pain and no pain groups separately

6.5 Discussion

The results of this study confirm that ergometer rowing provokes LBP in adolescent male rowers,^{31,47} with reported pain levels increasing over the duration of a 15-minute rowing trial in rowers with a presenting complaint of LBP during rowing (figure 6.2). A similar pattern of pain summation has been reported previously in cyclists with LBP during a 2-hour cycling trial.⁴⁸ This increase in pain intensity may reflect a temporal summation of pain, where a repetitive stimulus on pain sensitive structures may cause a gradual increase of pain sensation.^{34,36,46} There is debate as to the underlying mechanism for this phenomena, with some researchers suggesting that it reflects inhibitory and facilitatory mechanisms in the central nervous system,⁴⁵ whilst other authors suggest provocative movement behaviours may result in repeated stress on sensitised tissues with a resultant summation of pain.^{6,25} In reality a combination of both of these factors may interplay.

Another aim of this study was to determine whether adolescent male rowers with LBP posture their LLA and ULA in more flexion than rowers without LBP in the drive phase of ergometer rowing, and if this difference increases over 15 minutes of rowing. Although no differences in the mean LLA and ULA were detected overall or within the early, mid and late phase or 1st, 7th and 15th minute, on examination of the raw data prior to statistical analysis it was noted that rowers with LBP had greater variability in LLA and ULAs compared to rowers without LBP, and subsequent modeling confirmed these differences between groups. This finding was not an a priori aim of the study that warrants further investigation in larger samples. The variability in spinal kinematics in individuals with LBP is not a new concept, with higher variability in spinal movement in all of movements during functional tasks have been reported in adults with chronic LBP compared to no-LBP.^{10,49,51} This may be due to altered peripheral and central sensory processing of the nervous system, resulting in poorer spinal position sense in individuals with chronic LBP.² This poor reposition sense has also been reported in adolescents¹ and adults^{27,38} with LBP. During a lumbar spine reposition test, LBP individuals have a tendency to either under or over shoot a neutral sitting posture, a mechanism suggested to increase end range strain. Holt and

associates (2003) have also reported variations in spinal kinematics in athletes with and without LBP over a 60-minute ergometer trial,¹⁷ but no direct comparisons were made between the participants with and without a history of LBP.

On average, rowers in the pain group maintained their ULA in flexion in the drive phase [early (9.1°) mid (5.7°) and late (1.0°)] compared to rowers without pain who moved into more extension in the late phase [early (10.5°) mid(6.4°) late(-3.0°)]. In addition, rowers with LBP postured their ULA within 80% of end range flexion for a greater proportion of the drive phase than rowers without LBP (p=0.021). Interestingly, in spite of the general shift towards ULA flexion, there was still individual variability in the movement patterns highlighting the heterogeneity of the pain group. The increased proportion of drive phase spent in flexion in the rowers with LBP in this study further supports the existence of a *flexion pain provocation pattern* group in the classification system for patients with persistent mechanically induced LBP proposed by O'Sullivan (2000).²⁶ In this classification system for chronic LBP subjects, altered spinal motor control is proposed to result in directional strain to the spine with associated pain provocation.^{6,11,12,28,29} *Flexion pain provocation pattern* is where subjects report pain associated with sustained and repeated flexion loading.^{11,26} This pattern has previously been identified in kinematic studies of sitting^{12,29} and cycling^{6,48} As cycling and rowing are both seated sports, flexion loading may be a pain provocation pattern common to both sports, although caution should be placed in interpreting this finding due to the variability in ULA kinematics in rowers with LBP.

There were clear regional differences in the lumbar spine in the pain group that would not have been observed if it was considered in a single segment. These findings of regional differences are supported by a number of other studies in both sporting/non-sporting and pain/non-pain populations.^{8,11,14,21,22,30,50}

We acknowledge the following potential limitations of this study. 1) The sample size was small for the unexpectedly large variation reported in the

kinematics of the pain group participants. This may explain the lack of significant differences detected in the mean LLA and ULA between the LBP and the no-LBP group. 2) A subjective indicator of subject effort (RPE) was used in the study rather than an objective measurement of subjects' effort throughout the trial such as power output as it was commonly used in this age group to measure work rate in this group of rowers. Although variability in work rate will exist, the authors feel that this would be minimal and unlikely to invalidate comparisons between groups. 3) Force data were not collected to calculate spinal loading, as the aim of our study was to only investigate lumbar movement in the sagittal plane.

Although cross sectional studies do not give insight to causation, the results support the possibility that altered patterns of spinal motor control may be a mechanism for LBP, and lends supports to previous studies.^{25,26} Further research is needed to determine whether interventions that target changing lumbar kinematics during ergometer rowing may reduce LBP.

6.6 Conclusion

In conclusion, rowers with LBP demonstrated greater individual variation in spinal movement than rowers without LBP, and positioned their upper lumbar spine nearer end range flexion for a greater proportion of the drive phase. These findings may have implications for coaching practices, as well as strength and conditioning and clinical intervention strategies.

6.7 Findings

- There is a graduated increase in self-reported pain intensity during ergometer rowing in rowers with LBP.
- Rowers with LBP demonstrated greater variability in lumbar kinematics during ergometer rowing than rowers with no-LBP.
- Rowers with LBP postured their ULA near end range flexion for a greater proportion of the drive phase than rowers with no pain.

6.8 Implications

There are several clinical implications from the results of this study:

- 15 minutes of sustained ergometer rowing aggravated LBP to a high level of intensity suggesting that a continuous long ergometer training session may not be appropriate for rowers with rowing related LBP.
- Repeated flexion and sustained end range flexion spinal loading are known mechanical factors for LBP in the general population. Rowers with LBP demonstrated greater individual variability in spinal movement over a 15-minute ergometer rowing trial, and this may reflect adaptive movement patterns attempting to minimise flexion spinal loading stresses on the spine.
- Rowers with LBP demonstrated a greater proportion of the drive phase near end range flexion of the ULA, potentially placing them at risk for LBP due to end range tissue strain. This may represent a provocative motor control strategy for a repeated flexion-loading task.
- There is a need for individualised assessment of the movement pattern of rowers with back pain, as the variability identified by this study suggests that each rower may have different movement behaviours and responses to LBP.
- Researchers, clinicians and coaches should consider regional differences in lumbar spinal movement.
- Future intervention research (single case reports and randomised controlled trials) that focuses on reducing sustained flexion during rowing is needed to determine whether this changes LBP in this group.

6.9 References

1. Astfalck RG, O'Sullivan PB, Smith AJ, Straker LM, Burnett AF. Lumbar spine repositioning sense in adolescents with and without non-specific chronic low back pain - An analysis based on sub-classification and spinal regions. *Manual Therapy*. 2013;
2. Brumagne S, Cordo P, Lysens R, Verschueren S, Swinnen S. The role of paraspinal muscle spindles in lumbosacral position sense in individuals with and without low back pain. *Spine*. 2000;25:989-994.
3. Budgett RG. The road to success in international rowing. *British Journal of Sports Medicine*. 1989;23:49-50.
4. Bull AMJ, McGregor AH. Measuring spinal motion in rowers: the use of an electromagnetic device. *Clinical Biomechanics*. 2000;15:772-776.
5. Burnett AF, Barrett CJ, Marshall RN, Elliott BC, Day RE. Three-dimensional measurement of lumbar spine kinematics for fast bowlers in cricket. *Clinical Biomechanics*. 1998;13:574-583.
6. Burnett AF, Cornelius MW, Dankaerts W, O'Sullivan PB. Spinal kinematics and trunk muscle activity in cyclists: a comparison between healthy controls and non-specific chronic low back pain subjects - a pilot investigation. *Manual Therapy*. 2004;9:211-219.
7. Caldwell JS, McNair PJ, Williams M. The effects of repetitive motion on lumbar flexion and erector spinae muscle activity in rowers. *Clinical Biomechanics*. 2003;18:704-711.
8. Campbell A, Straker L, O'Sullivan P, Elliott B, Reid M. Lumbar Loading in the Elite Adolescent Tennis Serve: A Link to Low Back Pain. *Medicine & Science in Sports & Exercise*. In Press.
9. Childs JD, Piva SR, Fritz JM. Responsiveness of the numeric pain rating scale in patients with low back pain. *Spine*. 2005;30:1331-1334.
10. Claeys K, Brumagne S, Dankaerts W, Kiers H, Janssens L. Decreased variability in postural control strategies in young people with non-specific low back pain is associated with altered proprioceptive reweighting. *European Journal of Applied Physiology*. 2011;111:115-123.

11. Dankaerts W, O'Sullivan P, Burnett A, Straker L. Differences in sitting postures are associated with nonspecific chronic low back pain disorders when patients are subclassified. *Spine*. 2006;31:698-704.
12. Dankaerts W, O'Sullivan PB, Straker LM, Burnett AF, Skouen JS. The inter-examiner reliability of a classification method for non-specific chronic low back pain patients with motor control impairment. *Manual Therapy*. 2006;11:28-39.
13. Dolan P, Mannion AF, Adams MA. Fatigue of the erector spinae muscles a quantitative assessment using "frequency banding" of the surface electromyography signal. *Spine*. 1995;20:149-159.
14. Gill KP, Bennett SJ, Savelsbergh GJ, van Dieen JH. Regional changes in spine posture at lift onset with changes in lift distance and lift style. *Spine*. 2007;32:1599-1604.
15. Hestbaek L, Leboeuf-Yde C, Kyvik KO. Is comorbidity in adolescence a predictor for adult low back pain? A prospective study of a young population. *BMC Musculoskeletal Disorders*. 2006;16:7-29.
16. Hickey GJ, Fricker PA, McDonald WA. Injuries to elite rowers over a 10-yr period. *Medicine & Science in Sports & Exercise*. 1997;29:1567-1572.
17. Holt PJ, Bull AMJ, Cashman PM, McGregor AH. Kinematics of spinal motion during prolonged rowing. *International Journal of Sports Medicine*. 2003;24:597-602.
18. Hosea T, Bolard A, McCarthy K. Rowing injuries. *Post Graduate Advances in Sports Medicine*. 1989;University of Pennsylvania: Forum Medicum Inc.
19. Howell D. Musculoskeletal profile and incidence of musculoskeletal injuries in lightweight women rowers. *The American Journal of Sports Medicine*. 1984;12:278-281.
20. Lamb DH. A kinematic comparison of ergometer and on-water rowing. *The American Journal of Sports Medicine*. 1989;17:367-373.
21. Mitchell T, O'Sullivan PB, Burnett AF, Straker L, Smith A. Regional differences in lumbar spinal posture and the influence of low back pain. *BMC Musculoskeletal Disorders*. 2008;9:152-162.

22. Ng L, Burnett A, O'Sullivan P. Spino-pelvic kinematics and trunk muscle activation in prolonged ergometer rowing: mechanical etiology of non-specific low back pain in adolescent rowers. *26th International Conference on Biomechanics in Sports; July 14-18, 2008; Seoul National University, South Korea.*
23. Ng L, Burnett A, O'Sullivan P, Campbell A. Caution: The use of an electromagnetic device to measure trunk kinematics on rowing ergometers. *Sports Biomechanics*. 2009;8:255-259.
24. Ng L, Campbell AC, Burnett A, O'sullivan P. Gender differences in trunk and pelvic kinematics during prolonged ergometer rowing in adolescents. *Journal of Applied Biomechanics*. 2013;29:180-187.
25. O'Sullivan P. Diagnosis and classification of chronic low back pain disorders: Maladaptive movement and motor control impairments as underlying mechanism. *Manual Therapy*. 2005;10:242-255.
26. O'Sullivan PB. Masterclass. Lumbar segmental 'instability': clinical presentation and specific stabilizing exercise management. *Manual Therapy*. 2000;5:2-12.
27. O'Sullivan PB, Burnett A, Floyd AN, Gadsdon K, Logiudice J, Miller D, et al. Lumbar repositioning deficit in a specific low back pain population. *Spine*. 2003;28:1074-1079.
28. O'Sullivan PB, Grahamslaw KM, Kendell M, Lapenskie SC, Moller NE, Richards KV. The effect of different standing and sitting postures on trunk muscle activity in a pain-free population. *Spine*. 2002;27:1238-1244.
29. O'Sullivan PB, Mitchell T, Bulich P, Waller R, Holte J. The relationship between posture and back muscle endurance in industrial workers with flexion-related low back pain. *Manual Therapy*. 2006;11:264-271.
30. Parkinson S, Campbell A, Dankaerts W, Burnett A, O'Sullivan P. Upper and lower lumbar segments move differently during sit-to-stand. *Manual Therapy*. In Press.
31. Perich D. Low back pain in schoolgirl rowers: prevalence, bio-psycho-social factors and prevention [thesis]. Perth: Edith Cowan University; 2010.

32. Perich D, Burnett A, O'Sullivan P. Low back pain and the factors associated with it: Examination of adolescent female rowers. *24th International Conference on Biomechanics in Sports*. July 14-18, 2008; Salzburg, Austria.
33. Pollock CL, Jones IC, Jenkyn TR, Ivanova TD, Garland SJ. Changes in kinematics and trunk electromyography during a 2000 m race simulation in elite female rowers. *Scandinavian Journal of Medicine & Science in Sports*. 2012;22:478-487.
34. Price DD, Hu JW, Dubner R, Gracely R. Peripheral suppression of first pain and central summation of second pain evoked by noxious heat pulses. *Pain*. 1977;3:57-68.
35. Reid DA, Mcnair PJ. Factors contributing to low back pain in rowers. *British Journal of Sports Medicine*. 2000;34:321-322.
36. Robinson ME, Wise EA, Gagnon C, Fillingim RB, Price DD. Influences of gender role and anxiety on sex differences in temporal summation of pain. *The Journal of Pain*. 2004;5:77-82.
37. Roland M, Morris R. A study of the natural history of low back pain: Part 1. Development of a reliable and sensitive measure of disability in low-back pain. *Spine*. 1983;8:141-144.
38. Sheeran L, Sparkes V, Caterson B, Busse-Morris M, van Deursen R. Spinal position sense and trunk muscle activity during sitting and standing in nonspecific chronic low back pain: classification analysis. *Spine*. 2012;37:E486-495.
39. Smoljanovic T, Bojanic I, Hannafin JA, Hren D, Delimar D, Pecina M. Traumatic and overuse injuries among international elite junior rowers. *The American Journal of Sports Medicine*. 2009;37:1193-1199.
40. Solomonow M, Baratta RV, Zhou BH, Burger E, Zieske A, Gedalia A. Muscular dysfunction elicited by creep of lumbar viscoelastic tissue. *Journal of Electromyography and Kinesiology*. 2003;13:381-396.
41. Solomonow M, Zhou B, Baratta RV, Yun L, Harris M. Biomechanics of increased exposure to lumbar injury caused by cyclic loading: part 1. loss of reflexive muscular stabilization. *Spine*. 1999;24:2426-2434.

42. Solomonow M, Zhou BH, Baratta RV, Burger E. Biomechanics and electromyography of a cumulative lumbar disorder: response to static flexion. *Clinical Biomechanics*. 2003;18:890-898.
43. Strahan AD, Burnett AF, Caneiro JP, Doyle MM, O'Sullivan PB, Goodman C. Differences in spinopelvic kinematics in sweep and scull ergometer rowing. *Clinical Journal of Sport Medicine*. 2011;21:330-336.
44. Stratford P, Gill C, Westaway M, Binkley J. Assessing disability and change on individual patients: a report of a patient specific measure. *Physiotherapy Canada*. 1995;47:258-263.
45. Sullivan MJ, Lariviere C, Simmonds M. Activity-related summation of pain and functional disability in patients with whiplash injuries. *Pain*. 2010;151:440-446.
46. Sullivan MJ, Thibault P, Andrikonyte J, Butler H, Catchlove R, Lariviere C. Psychological influences on repetition-induced summation of activity-related pain in patients with chronic low back pain. *Pain*. 2009;141:70-78.
47. Teitz CC, O'Kane J, Lind B, Hannafin JA. Back pain in intercollegiate rowers. *The American Journal of Sports Medicine*. 2002;30:674-679.
48. Van Hoof W, Volkaerts K, O'Sullivan K, Verschueren S, Dankaerts W. Comparing lower lumbar kinematics in cyclists with low back pain (flexion pattern) versus asymptomatic controls - field study using a wireless posture monitoring system. *Manual Therapy*. 2012;17:312-317.
49. Vogt L, Pfeifer K, Portscher, Banzer W. Influences of nonspecific low back pain on three-dimensional lumbar spine kinematics in locomotion. *Spine*. 2001;26:1910-1919.
50. Wade M, Campbell AC, Smith A, Norcott J, O'Sullivan P. Investigation of spinal posture signatures and ground reaction forces during landing in elite female gymnasts. *Journal of Applied Biomechanics*. 2012;28:677-686.
51. Willigenburg NW, Kingma I, Hoozemans MJ, van Dieen JH. Precision control of trunk movement in low back pain patients. *Human Movement Science*. 2013;32:228-239.

52. Wilson F, Gissane C, Gormley J, Simms C. A 12-month prospective cohort study of injury in international rowers. *British Journal of Sports Medicine*. 2010;44:207-214.
53. Wilson F, Gissane C, Gormley J, Simms C. Sagittal plane motion of the lumbar spine during ergometer and single scull rowing. *Sports Biomechanics*. 2013;12(2):132-142.

Chapter 7 - Study 5

Cognitive functional therapy to manage low back pain in adolescent male rowers: a randomised controlled trial

Authors: Leo Ng, JP Cañeiro, Amity Campbell, Anne Smith, Angus Burnett, Peter O'Sullivan

The specific aim for Study 5 was:

- To investigate the efficacy of cognitive functional therapy in reducing pain and disability and whether it can alter trunk and lower limb muscle endurance, spinal posture and regional lumbar kinematics in adolescent male rowers with low back pain using a randomised controlled trial.

Study 5 has been formatted for the journal of *Medicine & Science in Sports & Exercise*.

7.1 Abstract

Purpose: This study aimed to evaluate the effects of cognitive functional therapy (CFT) in adolescent male rowers with low back pain (LBP).

Methods: Thirty-six adolescent male rowers reporting rowing related LBP were recruited for the study, 19 were randomly allocated to the intervention group to receive an 8-week CFT program targeting cognitive, movement and lifestyle factors relevant to each rower. The control group (n=17) received usual care. The assessor was blinded from the allocation. The primary outcome of the study was pain intensity as measured by the Numeric Pain Rating Scale (NPRS) during a 15-minute ergometer trial pre and post-intervention. The secondary outcomes of the study were disability as measured by Patient Specific Functional Scale (PSFS) and Roland Morris Disability Questionnaire (RMDQ) pre and post intervention and at 12-week follow up, isometric muscle endurance of the back extensors and lower limb muscles, usual sitting posture and regional trunk kinematic data during a 15-minute ergometer row collected using a 3D electromagnetic device pre and post treatment.

Results: Compared to the control group, the CFT group reported significantly less pain over 15 minutes of ergometer rowing (NPRS -2.4, 95% CI -4.1 to -0.63, $p=0.008$) and reduced disability (PSFS (4.1, 95% CI 0.9 to 7.3, $p=0.01$); RMDQ (-1.7, 95% CI -2.8 to -0.6, $p=0.003$)) following the intervention, and this was maintained at 12 weeks follow-up. They also demonstrated greater lower limb muscle endurance (20.9s, $p=0.03$) and postured their lower lumbar spine in greater extension during static sitting (-9.6° , $p=0.007$) post treatment. Improvement in back muscle endurance was observed in the CFT group, although this did not reach statistical significance (28.2s, $p=0.054$). Regional lumbar kinematics during ergometer rowing was unchanged.

Conclusion: CFT was effective in reducing pain and disability in adolescent male rowers, supporting the efficacy of this intervention for rowing-related LBP in an adolescent male population.

Keywords: biomechanics, spinal kinematics, physical therapy

7.2 Introduction

Low back pain (LBP) is common amongst adolescent rowers, with a high prevalence of LBP in adolescent male rowers (lifetime prevalence of 93.8% and point prevalence of 64.6%). LBP during adolescence is a known risk factor for the development of LBP in adulthood,¹³ where it is rated the number one musculoskeletal disorder for disability-adjusted life years (DALYs).²⁰

While it is acknowledged that LBP is a multifactorial condition with risk factors identified from physical, psychological, social, neurophysiological and lifestyle domains^{24,45}, the reported provocative nature of repetitive flexion spinal loading during rowing suggests that physical factors are likely to be the major contributor to LBP in this population.^{6,27,41}

The high training volumes coupled with cyclic compressive flexion loading of the lumbar spine during rowing have been suggested to be associated with LBP in rowers both on water³⁰ and with ergometer rowing.^{6,18,27,41,47,48} Previous research has established a relationship between time on ergometer rowing and pain^{21,47} with reports that ergometer rowing requires greater lumbar flexion than on-water scull rowing,⁴⁸ potentially leading to increased risk of back strain.

Although rowing increases the risk for LBP, not all rowers report LBP, suggesting that individual factors are also important. For example, poor lower limb and back muscle endurance have been associated with LBP in adolescent female rowers²⁷ and deficits in back muscle endurance in adult male rowers.³⁴ Although the direct mechanism for this is unclear, it has been proposed that deficits in muscle endurance may be a contributing factor to spinal loading and strain given the important role the lower limb and back muscles play in providing power during rowing.¹⁶ Sitting with increased lumbar spine flexion during usual sitting has also been associated with LBP in adolescent female rowers.²⁷ Further, in a pilot study, adolescent male and female rowers with LBP were shown to position their lower lumbar spine closer to end of range flexion throughout the drive phase of the rowing stroke

compared with pain free individuals.²¹ It has been proposed that these different findings may increase the vulnerability of the lumbar spine to end range flexion loading strain and pain.^{6,21}

Despite the high rate of LBP in rowers and given it has been demonstrated to shorten their careers,⁴² few intervention studies have been conducted in rowing populations. Recent calls for more targeted management of LBP have generally resulted in interventions being developed that are directed at the risk factors associated with different LBP disorders.^{12,25} Two recent non-randomised clinical trials have been conducted in adolescent female rowers targeting these risk factors utilising a cognitive functional therapy approach (CFT).^{26,42} Perich et al (2011) performed a study on 333 rowers aged between 14-17 with and without LBP.²⁶ Ninety-five rowers from one school were self allocated to receive a CFT intervention.²⁶ Each rower in the intervention group undertook a musculoskeletal screening involving an interview and a rowing-targeted physical examination.²⁶ The CFT approach included a group based education session to address the basic spinal mechanics and injury mechanisms for the lumbar spine; and prescribed individualised functional exercises that addressed specific deficits in lumbo-pelvic motor control identified by the examiners.²⁶ The result of this study showed a reduction in point prevalence of LBP, pain intensity and disability in the CFT group compared to the control group, which received no treatment.²⁶ Further, this study found rowers in the CFT group sat more upright and demonstrated improvements in back and lower limb muscle endurance.²⁶ A subsequent study, which was published earlier (n=82), also provided adolescent female rowers with a CFT intervention to adolescent female rowers.⁴² In contrast to the study by Perich et al (2011), both groups were from a single school receiving the same physical conditioning program and the education component of the CFT but only the intervention group received the specific functional training.⁴² The results of the study supported the finding that functional training reduced self-reported levels of pain and disability in adolescent female rowers.⁴² However, given that the participants in both studies allocated themselves into intervention or control groups, these results might have been confounded by motivation, self-selection bias and

uneven group sample sizes. Further, despite documented relationships between lumbar kinematics during ergometer rowing and LBP,²¹ these studies did not investigate the effect of the intervention on lumbar kinematics during rowing. Finally, this intervention has not been assessed using a randomised control trial (RCT) with blind assessor or in adolescent male rowers.

This study aimed to investigate the efficacy of CFT intervention on a group of adolescent male rowers in a RCT. The primary hypothesis was that rowers in the CFT group would row with lower levels of pain over the course of a 15-minute ergometer trial compared to a matched control group following the intervention. The secondary hypothesis was that rowers who underwent CFT would have; reduced disability, improved lower limb and back muscle endurance, demonstrate changes in habitual sitting posture and regional lumbar kinematics during ergometer rowing when compared to the control group.

7.3 Methods

Study Design: This study was a RCT with a blind investigator who performed all primary and secondary outcome data collection. The effects of the intervention on all outcome measures were assessed at 8-weeks and disability data also at 12-weeks follow-up. Permission to conduct the study was granted by the Human Research Ethics Committee at Curtin University in Perth, Western Australia (HR197/2008). This clinical trial was registered under the Australian and New Zealand Clinical Trials Registry (ACTRN12609000565246).

Participants and procedures

Participants

Thirty-six adolescent male rowers, aged between 14 and 19, who were suffering from LBP at the time of data collection (summer rowing season between 2009 -2011), were recruited from school-rowing clubs or community rowing clubs in Perth, Western Australia. Information sheets were given to all

potential participants and their parents/guardian and participant assent/consent was provided prior to their involvement in the study. The information sheets clearly stated the aims and the procedures of the study, and that there was one physiotherapy intervention group coupled with usual coaching care, and one active control group that received usual coaching care alone. The inclusion criteria for this study were that the participants were rowing competitively in local rowing regattas; indicated a self-reported LBP intensity of greater than 3/10 on the Visual Analogue Scale (VAS) during rowing; pain location within the lumbar region and posterior pelvis region (drawn on a diagram) with an onset during rowing training (see appendix L). The exclusion criteria included rowers with acute LBP, where the LBP intensity became so severe that it stopped the rower from participating in rowing training for more than 7 days in the 6 weeks preceding baseline data collection, such that it does not include LBP that are resolved by itself; a presence of specific causes of LBP such as inflammatory diseases; radicular pain or neurological signs to the lower limbs; or any musculoskeletal injuries to the extremities that limited rowing training in the 6-weeks prior to baseline data collection. The mean and standard deviation of the age, height, mass and body mass index (BMI) of participants in each group are displayed in Table 7.1. Power calculation estimated a sample size of 20 in each group to give 82% power to detect an overall difference in Numeric Pain Rating Scale (NPRS) scores of 1.5 points, based on an estimated standard deviation of 1.5 points in both groups, measures repeated over 15 minutes, and a within-subject correlation of 0.8 [(Stata/IC 12.1 for Windows (StataCorp LP, College Station, TX, USA)].

All subjects that elected to participate and had met the inclusion and exclusion criteria underwent baseline testing to determine; self reported pain intensity, disability as measured by the Patient Specific Functional Scale (PSFS) and by the Roland Morris Disability Questionnaires (RMDQ), lower limb and back muscle endurance, regional lumbar postures during usual sitting and regional lumbar kinematics during a 15-minute ergometer trial. Following this, the participants were randomised into the intervention and

control groups. All tests were repeated at 8-week follow-up. Only disability measures (PSFS and RMDQ) were re-assessed at the 12-week follow-up.

Testing Protocol

The participants first completed the PSFS, RMDQ, lower limb muscle endurance (LLME) and back muscle endurance (BME) test, which was conducted at a location of convenience for the rowers (local rowing club or at university laboratory). Regional lumbar angles during 'usual sitting' and ergometer rowing were collected using the 3-Space Fastrak™ system (Polhemus Navigation Science Division, Kaiser Aerospace, Vermont). A detailed description of how the regional lumbar angles were derived will be included in the laboratory analyses section of this paper. Following the 'usual sitting' test, the rowers were asked to complete a warm-up of 5 minutes sub-maximal rowing on a modified Concept II ergometer (ferrous metal replaced with wood to reduce electromagnetic interference). This was followed by ergometer testing, where the participants were requested to row at a very high intensity (17/20 on Borg RPE)(appendix K) at a stroke rate of 22 strokes per minute for a period of 15 minutes. This protocol has been modified from previous studies of 20-minutes to accommodate for pain experienced by rowers,^{21,23} and was determined after consultation between the researchers and coaches. During the ergometer trial, the rating of perceived exertion (RPE)³ was verbally collected at the beginning of every minute of the ergometer trial and also at the end of the 15-minute ergometer trial to standardise output during ergometer rowing between groups. Participants were advised to cease the ergometer trial if their level of pain during testing exceeded the level of pain during their usual rowing training or competition.

Randomisation

Following baseline assessment, the participants were randomly allocated to an intervention or control group (usual care) using the random number generator in Microsoft Excel 2003 (Excel version in Microsoft Office 2003 for Macintosh). The randomisation schedule was assembled by study research personnel uninvolved in data collection that was concealed from the assessor. Once eligibility and baseline assessment were confirmed, the

study assessor contacted the research personnel who informed the participant of intervention or non-intervention allocation and arranged for treatment as necessary.

Intervention

Cognitive Functional Therapy (CFT)

A CFT intervention was employed to address the rowers' LBP disorder according to each individual's classification as determined by the treating therapist. According to the participant's classification, each rower received a specific targeted intervention that aimed to modify what the clinician judged to be their primary contributing factors (cognitive, movement and lifestyle) linked to the person's disorder (Figure 7.1).^{12,25} A sports physiotherapist with 5 years experience with the Australian Rowing Team as well as training in the CFT directed the intervention. The intervention consisted of 2 to 5 sessions over 8-weeks. The participants attended a 1-hour initial appointment that involved a comprehensive interview and physical examination. This clinical examination followed a validated systematic approach,^{10,11,35} however it was also tailored to the participant's presentation. The interview aimed to acquire information regarding: current and previous history of pain, nature of pain and its location, pain behavior (aggravating and easing postures, movements and activities), primary functional impairments, pain coping strategies, treatment history, current levels of rowing training and general activity levels. The potential influence of other contributing factors such as sleep patterns and the influence of stress on pain levels and lifestyle, was also determined in the interview. The participants were questioned about their beliefs (regarding the cause of their pain, and what was necessary to address it) and their goals for the intervention. At the end of the interview the physiotherapist provided a summary of the information acquired and allowed the participants to add any further information deemed relevant. The physiotherapist also utilised the information from the RMDQ and PSFS of each individual in the diagnosis and classification of the disorder.

A systematic examination process was then conducted to analyse the participants' primary functional impairments (pain provocative postures,

movements and functional tasks reported during the interview and PSFS), assess their body awareness, whole body control, lumbo-pelvic control, as well as pain relieving postures and movements.²⁴ Detailed description of the musculoskeletal examination is outlined in the supplementary material 7.9. Clinical observation of the participant on the rowing ergometer allowed the physiotherapist to consider the rowers' movement strategy and identify maladaptive (provocative) movement patterns specific to rowing. Subsequently, the potential contributing factors to the LBP disorder and a targeted management plan was outlined to the rower. Follow-up appointments were 30 minutes in duration, patients were seen a week after the initial session and then fortnightly after that. The key elements of the intervention are presented in the supplementary material 7.9.

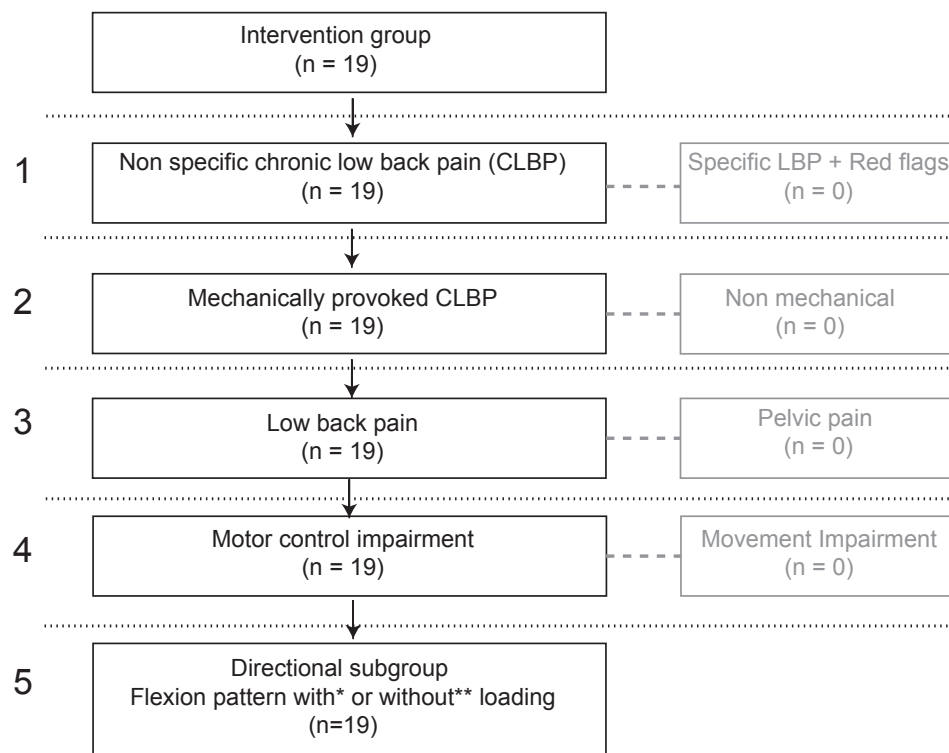

Figure 7.1 – Multidimensional classification system for LBP in adolescent male rowers in the intervention group

(Adapted from Fersum et al., 2012 and O'Sullivan et al., 2012)^{12,25}

* Flexion pattern with loading is pain associated with flexion loading, not necessarily at end of range flexion

** Flexion pattern without loading is pain associated with end of range flexion

Active Control Group

The control group received their usual level of care from their coaches, but no input from the physiotherapist involved with this study.

Outcomes

Primary Outcome

Numeric Pain Rating Scale (NPRS) - The primary outcome measurement was pain intensity during a 15-minute ergometer row (measured by the NPRS). The NPRS was collected verbally every minute during the 15-minute ergometer trial performed at both baseline and 8-week follow up. The NPRS is an 11-point scale (0-10) used to collect self-reported pain intensity and has a minimal clinical significant difference of 2.⁸

Secondary Outcomes

Roland Morris Disability Questionnaire (RMDQ) – The RMDQ is a validated questionnaire to measure disability as a result of LBP (appendix M).³² Individuals complete the questionnaire by rating the presence or absence of different aspects of disability as a result of LBP, where a score of 24 represents maximal disability and 0 represents no disability.³² The minimum clinically important difference for this questionnaire is 2.5.³³

Patient Specific Functional Scale (PSFS) – The PSFS was utilised in order to quantify self-reported functional disability on 3 activities participant's believed were most affected by their LBP (appendix N).³⁸ Rowers were asked to rate their level of functional disability relating to rowing and their two other most disabling activities. A score of 0 represents maximal disability and 10 represents no disability for each activity chosen, and an average score is calculated out of the 3 activities. The PSFS has a minimal clinical significant difference of 3 for one activity and 2 for the average of more than 1 activity.³⁸

Lower limb muscle endurance (LLME): The LLME was determined by an isometric squat test. This test evaluated the number of seconds the participants could keep their buttocks approximately 5cm off a stool with their

hips and knees flexed at 90° while their lumbar spine was in a neutral position.¹

Back muscle endurance (BME): The BME was determined by the Biering-Sorensens test.² This test evaluated the number of seconds the participants could keep their unsupported trunk in a horizontal prone position while the buttocks and legs were strapped onto a treatment plinth and their arms folded across their chest.^{2,36} The test ceased when the trunk was lowered by more than 10°, as measured by an inclinometer placed on the thoraco lumbar junction, or when the LBP became more severe than that usually experienced by the participant during rowing.^{2,36}

Regional lumbar angles during usual sitting: Regional lumbar angles during usual sitting were also collected at baseline and 8-week follow up using the 3-Space Fastrak™ system (Polhemus Navigation Science Division, Kaiser Aerospace, Vermont). For this purpose, each rower was asked to replicate his usual day-to-day sitting posture by holding a sitting posture for 5 minutes. Data was collected for 5 seconds, then the rowers were asked to change their sitting posture and return to their usual sitting posture 30 seconds later. This test was repeated twice and the average of the 3 trials were used as the participants' usual sitting angle. The sagittal Lower Lumbar Angle (LLA) and Upper Lumbar Angle (ULA) during usual sitting were derived from the same process described in the next section. This method of collecting kinematics have been used in previous research.^{10,19,21,23,37}

Regional lumbar kinematics during ergometer rowing: Regional lumbar kinematics during a 15-minute ergometer row were collected at baseline and 8-week follow-up using the 3-Space Fastrak™ system at 25 Hz (Polhemus Navigation Science Division, Kaiser Aerospace, Vermont). This has been shown to be a valid tool with an error of 0.4° when collecting spinal kinematics on a modified ergometer.²² The system consists of a systems electronic unit, a source and 3 sensors. The 3 sensors were attached onto the participant's skin overlying the spinous processes of S2, L3 and T12 using double sided tape and Fixomull®. The sensors detect an

electromagnetic field emitted from the source unit and a customised Labview software program (Version 8.6.1, National Instruments, Texas, USA) can determine three-dimensional (3D) positions and orientations of the sensors. A rotary encoder was linked to the flywheel of the rowing ergometer to time normalise the regional lumbar kinematics. The voltage generated by the rotary encoder was calibrated with a ruler prior to data collection to determine the phases of the rowing stroke (where the drive phase was defined as the period of time where the chain length went from shortest to longest) using a customised Labview software program (Version 8.6.1, National Instruments, Texas, USA). A further Labview program utilised matrix calculations⁴ to determine the following regional lumbar angles. This procedure has been used in previous kinematics studies in rowing^{21,23,37} (figure 7.2):

1. Lower Lumbar Angle (LLA) – angle of the L3 sensor relative to the S2 sensor.
2. Upper Lumbar Angle (ULA) – angle of the T12 sensor relative to the L3 sensor.

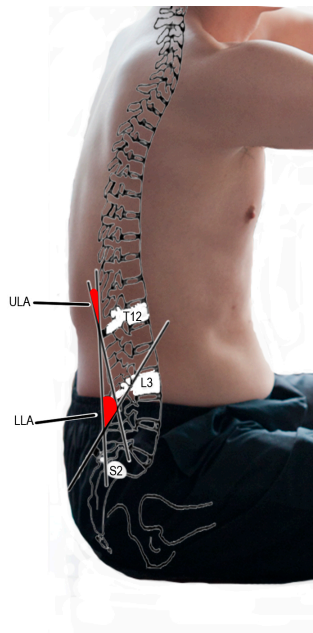

Figure 7.2 – Regional lumbar kinematics
(ULA – Upper Lumbar Angle; LLA – Lower Lumbar Angle)

Only sagittal plane angles from the drive phase were analysed, as there is minimal frontal and transverse plane movement when using a centre-pulled ergometer³⁷ and the greatest load occurs during the drive phase¹⁵. All data

were time normalised, with 0% defined as the beginning of the drive phase and 100% defined as the end of the drive phase in accordance with previous research.^{21,23}

Data and Statistical Analysis

Statistical Analysis

Primary Outcome

A series of linear mixed models with a random intercept and random slope for time was used to estimate group differences in the repeated NPRS measures recorded at the end of each minute of the post-treatment 15-minute ergometer rowing trial. To examine if the difference in NPRS between groups became larger over the 15 minutes of rowing, a groupXminute interaction term was evaluated, and the model was adjusted for maximum NPRS rating recorded during the pre-intervention ergometer trial. Linear mixed models with a random intercept were used to estimate group differences in disability (PSFS and RMDQ) at 8 and 12 weeks, adjusting for baseline disability and age.

Secondary Outcomes

Linear regression models were used to estimate group differences in muscle endurance and usual sitting posture angles, adjusting for the baseline measure of outcome and age. Kinematic data collected over the 15 minutes of rowing was evaluated for group differences using two measures. Firstly, the excursion of the upper and lower lumbar angles over the drive phase was calculated as the difference between the minimum and maximum flexion angle measures taken at percentiles of the drive phase from three completed strokes, at the 1st, 7th and 15th minute of rowing. Two linear mixed-effects models (for upper and lower LA) were used to evaluate treatment group differences in excursion adjusted for minute, baseline measure and age. GroupXminute interactions were also assessed to examine if treatment group differences varied according to these minutes. Secondly, flexion angle measures taken at percentiles of the drive phase from three completed strokes were averaged to produce a single flexion angle (for both upper and

lower lumbar) for the early (0 - 20th %ile), mid (30-70th %ile) and late (80 - 100th %ile) drive phase, at the end of the 1st, 7th and 15th minute of rowing. Two linear mixed-effects models (for upper and lower LA) were used to evaluate treatment group differences adjusted for minute, phase, baseline values and age. GroupXminute and groupXphase interactions were also assessed to examine if treatment group differences varied according to these factors. All models were examined to confirm the absence of influential outlying observations. Statistical analysis was performed using Stata/IC 12.1 for Windows (StataCorp LP, College Station, TX, USA).

7.4 Results

Out of the 153 patients that were assessed for eligibility, 36 rowers consented to participate in this study. In the randomised cohort, 17 were allocated to control and 19 were allocated to CFT. The outline of the participants from assessment of eligibility to 12-week follow up is displayed in Figure 7.3.

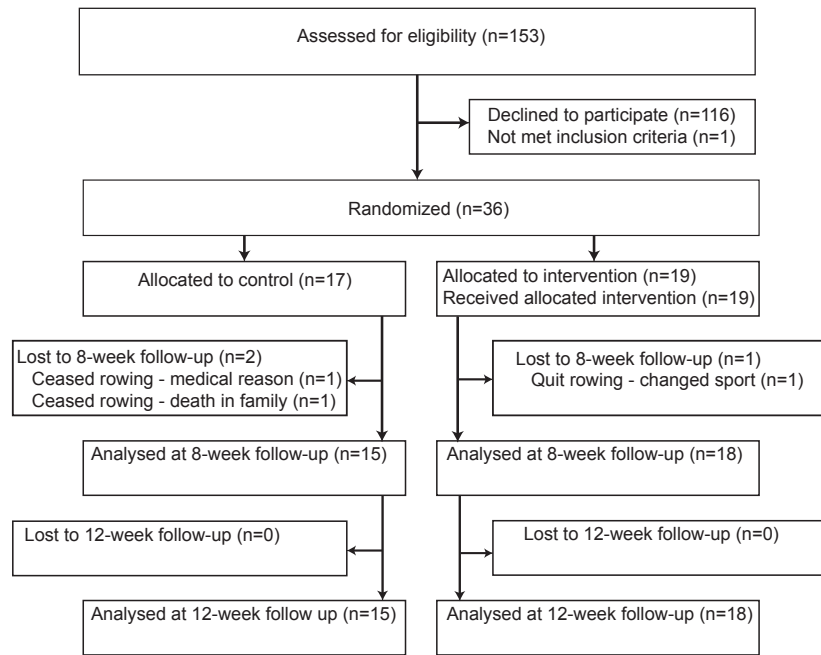

Figure 7.3 – flow chart depicting participant recruitment, randomisation allocation to CFT intervention and control group and retention of participants

Table 7.1 – unadjusted mean baseline characteristics between control and intervention group

	Control Mean (SD)	Intervention Mean (SD)
Characteristics		
Age	15.2 (1.5)	16.4 (1.5)
Height (m)	1.76 (0.09)	1.80 (0.09)
Mass (kg)	69.4 (14.2)	76.4 (14.5)
BMI (kg/m ²)	22.4 (3.9)	23.4 (3.2)
Primary Outcome		
Mean maximum pain during ergometer rowing	6.0/10	5.2/10
Secondary Outcomes		
Disability		
PSFS (/30)	18.0 (5.8)	15.5 (5.9)
RMDQ (/24)	3.4 (5.8)	4.1 (5.9)
Muscle Endurance Tests (s)		
Lower limb endurance	38.1 (21.8)	45.6 (34.1)
Back muscle endurance	95.5 (21.1)	104.2 (41.3)
Lumbar kinematics (° of flexion)		
Sitting Posture		
Lower Lumbar Angle (LLA)	4.9 (9.5)	0.0 (11.0)
Upper Lumbar Angle (ULA)	1.5 (9.2)	3.5 (6.8)
Ergometer kinematics		
Rowing angle (excursion)		
Lower Lumbar Angle (LLA)	12.2 (7.8)	17.3 (15.0)
Upper Lumbar Angle (ULA)	12.0 (9.4)	12.8 (9.0)
Rowing angle (mean)		
Lower Lumbar Angle (LLA)	1.4 (15.1)	-2.8 (24.7)
Upper Lumbar Angle (ULA)	1.5 (9.2)	3.5 (6.8)

Treatment fidelity

The physiotherapist applied several strategies to improve treatment fidelity. Clinical notes including treatment content as well as a copy of the participant's exercise sheets were documented in each session. An exercise sheet was given to each rower in the intervention group containing written and drawn information specifying the correct and incorrect form of execution of their individual exercises. This document also included repetitions, sets and frequency of exercises as well as set goals (i.e. time, repetition or range) to be achieved between sessions. For some of the more complex exercises, such as those that targeted the change in lumbar kinematics during ergometer rowing, videos were taken (on the participants' phone device) of the correct and incorrect technique of these exercises (example of these exercises are illustrated in the supplementary appendix 7.9). Considering the

age of the participants, a parent or their coach always accompanied them during each treatment session. This person was asked to encourage the rower to follow treatment plan. The mean number of treatments was 3.6 (range 2-5; SD 1.1) in the CFT group. Similar to standard clinical practice, treatment was discontinued if the therapist deemed the participant had no further need for treatment before the 8 weeks were completed.

Primary Outcome

NPRS during 15 min ergometer rowing

Figure 7.4 presents the pre and post-intervention group means for NPRS over the 15-minute ergometer trial. Not all rowers were able to complete the 15-minute ergometer trial due to their pain level during testing. At baseline, 1 rower was unable to complete the 15-minute ergometer trial (ceased at 9th minute due to LBP) in the control group and 5 rowers were unable to complete the trial (2 ceased at 7th minute due to LBP; and 2 at 9th minute due to LBP and 1 at 10th minute due to muscle cramping) in the intervention group due to LBP. At 8-week follow up, 1 rower was unable to complete the ergometer trial (ceased at 10th minute due to LBP) in the control group and 3 were unable to complete the trial at follow-up (1 rower ceased at 7th minute due to LBP; 1 at 7th minute due to reported fatigue; and 1 at 10th minute due to reported muscle cramping) in the intervention group.

Results of the linear mixed model indicated that rowers in the treatment group had a significantly lower rate of increase in pain (0.15 points per minute, 95%CI:0.07 to 0.23, $p<.001$) than the control group (0.27 points per minute, 95%CI:0.19 to 0.36, $p<.001$), with the difference in the slope coefficient estimated to be -0.12 (95%CI:-0.24 to -0.01, $p=.035$). It was estimated from the model that over the ergometer trial period, rowers in the treatment group reported significantly lower NPRS ratings from the 3rd minute (Difference=-0.9, 95%CI:-1.8 to -0.1, $p=0.048$) upwards, with the estimated group difference increasing in magnitude up to the 15th minute (-2.4, 95%CI:-4.1 to -0.63, $p=.008$). Although all the data were considered in the analysis, it must be acknowledged that 3 rowers from the intervention group could not complete the 15-minute ergometer trial at the follow-up data collection.

However, only 1 was due to LBP in the 8-week follow up data collection, whereas 4 rowers were unable to complete the trial at pre-intervention data collection due to LBP.

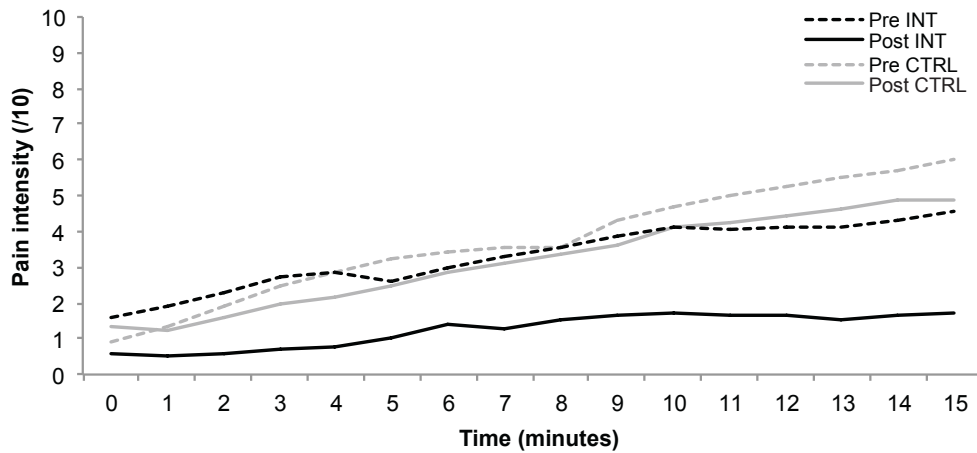

Figure 7.4 – Numeric pain rating scale during ergometer rowing at pre-intervention laboratory analysis and post-intervention laboratory analysis between the control and the intervention groups

Secondary Outcomes

Rowers in the intervention group had significantly less disability immediately following intervention compared to the control group as measured by the PSFS (4.1, 95% CI;0.9 to 7.3, $p=.013$) and the RMDQ (-1.7, 95% CI;-2.8 to -0.6, $p=.003$) Table 7.2). Further, the group difference in disability was maintained at the 12-week follow-up (Table 7.2).

Table 7.2 – Unadjusted Secondary Outcomes at baseline, 8-week follow up and 12-week follow up and estimated group difference adjusted for baseline measures and age

	Control Mean (SD)^a	Intervention Mean (SD)^a	β^b	95% CI	p-value
PSFS					
Baseline	18.0 (5.8)	15.5 (5.9)			
8-week	22.0 (4.3)	25.0 (4.0)	4.1	0.9, 7.3	0.013*
12-week	23.1 (4.9)	26.1 (3.5)	4.0	0.8, 7.2	0.014*
RMDQ					
Baseline	3.4 (5.8)	4.1 (5.9)			
8-week	2.6 (4.3)	1.2 (4.0)	-1.7	-2.8, -0.6	0.003*
12-week	2.0 (4.9)	0.9 (3.5)	-1.4	-2.6, -0.3	0.013*
Muscle Endurance Tests (s)					
Back Endurance Test					
Baseline	95.5 (21.1)	104.2 (41.3)			
8-week	92.0 (34.6)	122.5 (33.9)	28.2	-0.5, 56.9	0.054
Lower Limb Endurance					
Baseline	38.1 (21.8)	45.6 (34.1)			
8-week	47.2 (25.0)	65.8 (39.5)	20.9	2.0, 39.7	0.031*
Static sitting kinematics (°)					
Lower Lumbar Angle (LLA)					
Baseline	4.9 (9.5)	0.0 (11.0)			
8-week	7.1 (7.1)	-2.6 (6.9)	-9.6	-16.4, -2.9	0.007*
Upper Lumbar Angle (ULA)					
Baseline	1.5 (9.2)	3.5 (6.8)			
8-week	3.7 (6.4)	1.1 (8.7)	-3.0	-10.6, 4.5	0.417
Ergometer kinematics (°)					
Lower Lumbar Angle (LLA) excursion over drive phase ¹					
Baseline	12.2 (7.8)	17.3 (15.0)			
8-week	11.3 (7.3)	14.2 (12.7)	4.3	-3.2, 11.8	0.261
Lower Lumbar Angle (LLA) ²					
Baseline	1.4 (15.1)	-2.8 (24.7)			
8-week	-3.6 (16.7)	1.3 (11.4)	2.1	-6.7, 11.0	0.635
Upper Lumbar Angle (ULA) excursion over drive phase ¹					
Baseline	12.0 (9.4)	12.8 (9.0)			
8-week	8.0 (4.2)	11.4 (8.5)	-0.5	-5.2, 4.2	0.834
Lower Lumbar Angle (LLA) ²					
Baseline	3.6 (10.3)	5.7 (9.6)			
8-week	6.8 (8.9)	3.4 (15.5)	-1.5	-11.7, 8.8	0.775

^aUnadjusted means

^bDifference in means adjusted for age and baseline disability levels

¹Adjusted for minute

²Adjusted for phase and minute

Muscle Endurance

Rowers in the intervention group had significantly improved LLME following intervention compared to the control group (group difference: 20.9s, 95% CI: 2.0, 39.7; p=0.031)(Table 7.2). Although the sample estimate of post-intervention BME was 28.2s greater in the intervention group than the control

group, this estimate was not statistically significant at alpha 0.05 (95% CI: 2.0, 39.7; $p=0.054$) (Table 7.2).

Usual Sitting posture

Rowers in the treatment group postured their LLA during static sitting in less flexion following intervention compared to the control group (group difference: -9.6° , 95% CI: -16.4, -2.9; $p=0.007$). No statistically significant difference was observed in the ULA during static sitting between the treatment group and control group (group difference: -3.0° , 95% CI: -10.6, 4.5; $p=0.417$) (Table 7.2).

Regional Lumbar kinematics during ergometer rowing

There were no significant differences between the intervention group and control group in upper or lower lumbar angle kinematics during rowing (Table 7.2). No interactions between treatment group and minute, or treatment group and phase were detected, meaning there was no evidence that treatment group differences varied significantly with these factors.

7.5 Discussion

Results overview

This is the first randomised controlled trial to assess the efficacy of a targeted LBP intervention in rowers. The results of this study reveal that rowers who received CFT had reductions in pain intensity levels during ergometer rowing and reduced disability levels compared to rowers in a control group. Further, rowers who received CFT demonstrated an increase in LLME, and sat with greater lower lumbar extension compared to the control group. Although no statistical difference in BME were found between groups, the change in BME observed following intervention may be clinically relevant. There were no differences in regional lumbar kinematics during ergometer rowing.

Pain summation

All participants experienced a gradual increase of self-reported pain intensity levels during the pre-intervention 15-minute ergometer row data collection (Figure 7.4). This result corroborates previous findings of a ramping of self-reported pain intensity levels in adolescent rowers during ergometer rowing.²¹ This may reflect a repetition-induced summation of activity related pain, where repetitive stimulus (mechanical stimulus from forward bending) on pain sensitive structures causes an amplification of pain perception, which has been reported previously in repeated lifting tasks.^{29,31,39,40} The intervention group (n = 19) demonstrated significantly reduced pain intensity levels linked to a reduction in pain ramping in comparison to the control group (n= 17). It is likely these findings reflect a reduction in the sensitisation of lumbar spine structures to repeated flexion loading following the intervention. This may have been facilitated via reduced stress load on sensitised spinal structures following the intervention as well as the potential for reduced central drive due to the cognitive functional aspects of the intervention. Previous research has also reported this phenomenon in cyclists where reductions on flexion loading reduced pain summations suggesting that motor control factors may be important in sporting groups who demonstrate this.⁴⁴

Disability

Both groups experienced reduced Disability. However, the reductions were statistically greater in the CFT group than the control group, and greater than the difference considered to be of 'minimal clinical importance' in the RMDQ, PSFS and the rowing item of the PSFS.^{33,38} These findings match those of two non-randomised trials in adolescent female rowers^{26,42} The reduction in disability may be due to the significant reduction of pain experienced during ergometer rowing. The cognitive functional and conditioning components of the CFT provided active pain coping strategies via functionally targeted training, which may have provided rowers in the treatment group with the ability to row and carry out functional tasks with greater confidence and self efficacy.

Muscle endurance

The improvement in LLME in the intervention group is consistent with the targeted nature of the rowing-specific conditioning exercises, and corroborates the previous findings of a non-randomised trial of the efficacy of CFT in adolescent female rowers.²⁶ It is postulated that poor LLME may increase flexion loading of the lumbar spine as it has been shown to increase lumbar flexion during repeated lifting tasks in adult workers.⁴³ Further, weakness in the gluteal muscles has been reported to result in increased co-contraction of the lumbar spinal muscles, potentially leading to increased lumbar spinal loading during leg loading tasks.²⁸ Although no statistically significant differences were found in the BME, the 28.2s experienced between groups is likely to be of clinical importance as previous research with a larger sample size (n=56) reported similar sized differences (28.9s) differentiated adolescents with and from those without LBP.¹ Fatigue of the back extensors was also shown to increase lumbar flexion during ergometer rowing in adolescent rowers,⁶ although this was not observed in our study. Therefore improving LLME and BME may act to increase load tolerance across the lumbar spine during rowing. It is also possible that the increased endurance times reflected increased self efficacy and less pain sensitivity – factors known to be linked to BME in previous research.^{17,36}

Sitting posture

The LLA during usual sitting was more extended following CFT in the intervention group as compared to the control group. This is also consistent with a previous study by Perich et al (2011) who reported that adolescent female rowers sat more upright following CFT.²⁶ This is associated with CFT where subjects are trained to sit with a neutral lordosis if they are sensitised to flexion loading. Sitting in a position near end of range of lumbar flexion has also been associated with reduced back extensor muscle activity and poor BME.^{9,36} It is therefore possible that more upright sitting correlated with the trend towards greater BME observed in the intervention group. Although previous studies have shown a correlation between flexed sitting and flexed lifting and bending postures,^{19,46} there was no similar relationship between sitting posture and rowing posture observed in this study.

Regional lumbar kinematics during rowing

This is the first cross-sectional study to investigate whether CFT results in regional lumbar kinematics changes during ergometer rowing. Contrary to our hypothesis, the results support that there was no consistent change in the regional lumbar kinematics during ergometer rowing across the group following the CFT intervention. This may suggest that the reductions in pain and disability observed following the intervention were related to enhanced load tolerance during rowing, rather than due to a change in spinal kinematics. However it cannot be ruled out that the variability of individual differences in kinematics were washed out in the group analysis as outlined in the case study in the following chapter.⁷ Further single case analyses are required to test this hypothesis. Conducting interventions in larger groups would also allow for subgroup analysis that was not possible given our sample size.

The positive results of the intervention match those of previous studies in adolescent female rowers,^{26,42} cyclists,⁴⁴ and adult subjects with chronic LBP.¹² The contribution of each individual component of the intervention in the present study still remains unknown. Future studies are required to determine whether changes in other factors such as tissue sensitivity, body awareness / schema, pain coping and confidence potentially mediate the change when intervening with LBP using this approach. In reality, it is likely that a combination of factors, which differ between individuals, were responsible for the reduction of LBP intensity and disability in this cohort and others.

There are some potential limitations to this study. First, the trial compared a group of rowers who underwent treatment versus no active treatment, potentially biasing the results. Future research should compare CFT with other forms of active treatment. The multidimensional nature of CFT suggests that it remains unclear whether one component of the treatment was superior to the other although the findings of this study and that of Thorpe suggest that the targeted functional training may be the key component to the intervention. Also, timing of the ergometer trials could not

be standardised between participants due to their availability and the rowing program. The timing of the ergometer trial in relation to rowing training and competition may affect fatigue level in young non-elite rowers. Further, the rowers were not controlled for the type and intensity of sports participation outside of rowing, high levels of physical activities may also be a contributing factor to LBP.⁵ This study did not use electromyography of the trunk muscles during ergometer rowing which previous studies have shown to be discriminatory.³⁴ Psychosocial factors were not measured in this study, although given the low levels of disability in the group, its unlikely that they were a major factor.¹⁴ The population investigated in this study was adolescent male rowers with LBP, and the results cannot be generalised beyond this age group and level of competitiveness. Work rate during ergometer testing was only standardised between groups using self-reported RPE in line with previous ergometer studies by the authors.^{21,23}

What is already known on this topic:

- CFT has been shown to be effective clinically in the treatment of LBP in adolescent female rowers in two non-RCT designed studies.

What this study adds:

- CFT was effective in reducing pain summation during ergometer rowing and disability levels in adolescent male rowers using a RCT design.
- The reduction in pain and disability were associated with changes in LLME and lower lumbar sitting posture.

7.6 Conclusion

A CFT approach was effective in reducing pain and disability in adolescent male rowers. This was associated with increased LLME and more extended lower lumbar spine posture in usual sitting. However, it was not associated with observed changes in spinal kinematics during ergometer rowing.

7.7 Acknowledgement

This study was supported by research grants from the Physiotherapy Research Foundation; a tagged Sports Physiotherapy Australia grant (T09-THE/SPA001). The funding body was not otherwise involved with this study, including participant recruitment and allocation, data collection or intervention in any form.

7.8 References

1. Astfalck RG, O'Sullivan PB, Straker LM, Smith AJ. A detailed characterisation of pain, disability, physical and psychological features of a small group of adolescents with non-specific chronic low back pain. *Manual Therapy*. 2010;15(3):240-247.
2. Biering-Sorensen F. Physical measurements as risk indicators for low-back trouble over a one-year period. *Spine*. 1984;9(2):106-119.
3. Borg G. Perceived exertion as an indicator of somatic stress. *Scandinavian Journal of Rehabilitative Medicine*. 1970;2(3):92-98.
4. Burnett AF, Barrett CJ, Marshall RN, Elliott BC, Day RE. Three-dimensional measurement of lumbar spine kinematics for fast bowlers in cricket. *Clinical Biomechanics*. 1998;13(8):574-583.
5. Burton AK, Clarke RD, McClune TD, Tillotson KM. The natural history of low back pain in adolescents. *Spine*. 1996;21(20):2323-2328.
6. Caldwell JS, McNair PJ, Williams M. The effects of repetitive motion on lumbar flexion and erector spinae muscle activity in rowers. *Clinical Biomechanics*. 2003;18(8):704-711.
7. Cañeiro JP, Ng L, Burnett A, Campbell A, O'Sullivan P. Cognitive functional therapy for the management of low back pain in an adolescent male rower: a case report. *Journal of Orthopaedic & Sports Physical Therapy*. 2013;43(8):542-554.
8. Cole B, Finch E, Gowland C, Mayo N. *Physical Rehabilitation Outcome Measures*. Baltimore: Williams and Wilkins; 1995.
9. Dankaerts W, O'Sullivan P, Burnett A, Straker L. Altered patterns of superficial trunk muscle activation during sitting in non-specific chronic low back pain patients: importance of sub-classification. *Spine*. 2006;31(17):2017-2023.
10. Dankaerts W, O'Sullivan P, Burnett A, Straker L, Davey P, Gupta R. Discriminating healthy controls and two clinical subgroups of nonspecific chronic low back pain patients using trunk muscle activation and lumbosacral kinematics of postures and movements: a statistical classification model. *Spine*. 2009;34(15):1610-1618.
11. Dankaerts W, O'Sullivan PB, Burnett AF, Straker LM. The use of a mechanism-based classification system to evaluate and direct

management of a patient with non-specific chronic low back pain and motor control impairment - a case report. *Manual Therapy*.

2007;12(2):181-191.

12. Fersum KV, O'Sullivan P, Skouen JS, Smith A, Kvale A. Efficacy of classification-based cognitive functional therapy in patients with non-specific chronic low back pain: A randomized controlled trial. *European Journal of Pain*. 2012.
13. Hestbaek L, Leboeuf-Yde C, Kyvik KO, Manniche C. The course of low back pain from adolescence to adulthood: eight-year follow-up of 9600 twins. *Spine*. 2006;31(4):468-472.
14. Hill JC, Whitehurst DGT, Lewis M, Bryan S, Dunn KM, Foster NE, et al. Comparison of stratified primary care management for low back pain with current best practice (STarT Back): a randomised controlled trial. *Lancet*. 2011;378(9802):1560-1571.
15. Hosea T, Bolard A, McCarthy K. Rowing injuries. *Post Graduate Advances in Sports Medicine*. 1989:University of Pennsylvania: Forum Medicum Inc.
16. Hosea TM, Hannafin JA. Rowing injuries. *Sports Health*. 2012;4(3):236-245.
17. Mannion AF, Muntener M, Taimela S, Dvorak J. A randomized clinical trial of three active therapies for chronic low back pain. *Spine (Philadelphia, Pa 1976)*. 1999;24(23):2435-2448.
18. McGregor AH, Bull AM, Byng-Maddick R. A comparison of rowing technique at different stroke rates: a description of sequencing, force production and kinematics. *International Journal of Sports Medicine*. 2004;26(6):465-470.
19. Mitchell T, O'Sullivan PB, Burnett AF, Straker L, Smith A. Regional differences in lumbar spinal posture and the influence of low back pain. *BMC Musculoskeletal Disorders*. 2008;9:152-162.
20. Murray CJ, Vos T, Lozano R, Naghavi M, Flaxman AD, Michaud C, et al. Disability-adjusted life years (DALYs) for 291 diseases and injuries in 21 regions, 1990-2010: a systematic analysis for the Global Burden of Disease Study 2010. *Lancet*. 2012;380(9859):2197-2223.

21. Ng L, Burnett A, O'Sullivan P. Spino-pelvic kinematics and trunk muscle activation in prolonged ergometer rowing: mechanical etiology of non-specific low back pain in adolescent rowers. *26th International Conference on Biomechanics in Sports*; July 14-18, 2008; Seoul, South Korea.
22. Ng L, Burnett A, O'Sullivan P, Campbell A. Caution: The use of an electromagnetic device to measure trunk kinematics on rowing ergometers. *Sports Biomechanics*. 2009;8(3):255-259.
23. Ng L, Campbell AC, Burnett A, O'sullivan P. Gender differences in trunk and pelvic kinematics during prolonged ergometer rowing in adolescents. *Journal of Applied Biomechanics*. 2013;29(2):180-187.
24. O'Sullivan P. Diagnosis and classification of chronic low back pain disorders: Maladaptive movement and motor control impairments as underlying mechanism. *Manual Therapy*. 2005;10(4):242-255.
25. O'Sullivan P. A classification-based cognitive functional approach for the management of back pain. *Journal of Orthopaedic & Sports Physical Therapy*. 2012;42(10):A17-A21.
26. Perich D, Burnett A, O'Sullivan F, Perkins C. Low back pain in adolescent female rowers: A multi-dimensional intervention study. *Knee Surgery, Sports Traumatology and Arthroscopy*. 2011;19(1):20-28.
27. Perich D, Burnett A, O'Sullivan P. Low back pain and the factors associated with it: Examination of adolescent female rowers. Paper presented at: *24th International Symposium on Biomechanics in Sports*; July 14-18, 2006; Salzburg, Austria.
28. Popovich JM, Jr., Kulig K. Lumbopelvic landing kinematics and EMG in women with contrasting hip strength. *Medicine & Science in Sports & Exercise*. 2012;44(1):146-153.
29. Price DD, Hu JW, Dubner R, Gracely R. Peripheral suppression of first pain and central summation of second pain evoked by noxious heat pulses. *Pain*. 1977;3(1):57-68.
30. Reid DA, Mcnair PJ. Factors contributing to low back pain in rowers. *British Journal of Sports Medicine*. 2000;34(5):321-322.

31. Robinson ME, Wise EA, Gagnon C, Fillingim RB, Price DD. Influences of gender role and anxiety on sex differences in temporal summation of pain. *The Journal of Pain*. 2004;5(2):77-82.
32. Roland M, Fairbank J. The Roland-Morris disability questionnaire and the Oswestry disability questionnaire. *Spine*. 2000;25(24):3115-3124.
33. Roland M, Morris R. A study of the natural history of low back pain: Part 1. Development of a reliable and sensitive measure of disability in low-back pain. *Spine*. 1983;8(2):141-144.
34. Roy SH, De Luca CJ, Snyder-Mackler L, Emley MS, Crenshaw RL, Lyons J. Fatigue, recovery, and low back pain in varsity rowers. *Medicine & Science in Sports & Exercise*. 1990;22(4):463-469.
35. Sheeran L, Sparkes V, Caterson B, Busse-Morris M, van Deursen R. Spinal position sense and trunk muscle activity during sitting and standing in nonspecific chronic low back pain: classification analysis. *Spine*. 2012;37(8):E486-495.
36. Smith AJ, O'Sullivan PB, Campbell AC, Straker LM. The relationship between back muscle endurance and physical, lifestyle, and psychological factors in adolescents. *Journal of Orthopaedic & Sports Physical Therapy*. 2010;40(8):517-523.
37. Strahan AD, Burnett AF, Caneiro JP, Doyle MM, O'Sullivan PB, Goodman C. Differences in spinopelvic kinematics in sweep and scull ergometer rowing. *Clinical Journal of Sport Medicine*. 2011;21(4):330-336.
38. Stratford P, Gill C, Westaway M, Binkley J. Assessing disability and change on individual patients: a report of a patient specific measure. *Physiotherapy Canada*. 1995;47(4):258-263.
39. Sullivan MJ, Lariviere C, Simmonds M. Activity-related summation of pain and functional disability in patients with whiplash injuries. *Pain*. 2010;151(2):440-446.
40. Sullivan MJ, Thibault P, Andrikonyte J, Butler H, Catchlove R, Lariviere C. Psychological influences on repetition-induced summation of activity-related pain in patients with chronic low back pain. *Pain*. 2009;141(1-2):70-78.

41. Teitz CC, O'Kane J, Lind B, Hannafin JA. Back pain in intercollegiate rowers. *The American Journal of Sports Medicine*. 2002;30(5):674-679.
42. Thorpe A, O'Sullivan P, Burnett A, Caneiro J-P. Assessing the efficacy of a specific physiotherapy intervention for the prevention of low back pain in female adolescent rowers: A field study. *New Zealand Journal of Sports Medicine*. 2009;32(2):38-46.
43. Trafimow JH, Schipplein OD, Novak GJ, Andersson GB. The effects of quadriceps fatigue on the technique of lifting. *Spine*. 1993;18(3):364-367.
44. Van Hoof W, Volkaerts K, O'Sullivan K, Verschueren S, Dankaerts W. Cognitive functional therapy intervention including biofeedback for LBP during cycling. A single case study *Sport and Geneeskunde*. 2011;44(4):20-26.
45. Waddell G, Burton AK. Concepts of rehabilitation for the management of low back pain. *Best practice & research. Clinical Rheumatology*. 2005;19(4):655-670.
46. Wade M, Campbell AC, Smith A, Norcott J, O'Sullivan P. Investigation of spinal posture signatures and ground reaction forces during landing in elite female gymnasts. *Journal of Applied Biomechanics*. 2012;28(6):677-686.
47. Wilson F, Gissane C, Gormley J, Simms C. A 12-month prospective cohort study of injury in international rowers. *British Journal of Sports Medicine*. 2010;44(3):207-214.
48. Wilson F, Gissane C, Gormley J, Simms C. Sagittal plane motion of the lumbar spine during ergometer and single scull rowing. *Sports Biomechanics*. 2013;12(2):132-142.

7.9 Supplementary material

Physical examination

Key elements:

A comprehensive physical examination was conducted including standard musculoskeletal examination elements (including spinal range of movement, hip range of movement, hamstring flexibility, motion palpation of the spine and myofascial palpation), rowing specific testing and testing according to the multidimensional classification system as listed below.²⁴

Tests

Description

Assessment of spinal repositioning sense

Spinal repositioning sense in sitting¹ and on the ergometer rowing.

Assessment of pain provocative postures

Identify provocative movement patterns in the specific tasks nominated by the participants and to find alternative movement strategies that allowed them to perform these tasks in a pain-reduced manner.^{11,24}

Specific movement testing

Testing the ability of the participant to dissociate movement of the thorax, and lumbo- pelvic region.²⁴

Lumbo-pelvic motor control assessment in functional tasks

Ability for rowers to maintain a neutral lumbar spine with a relaxed thorax during functional activities such as:

Sitting performing active hip flexion



Sitting performing active hip flexion and knee extension



Sitting bending with forward reach



Sit to stand



Squat with forward reach



Single-leg squat



Simulated row position



Clinical observation
on ergometer rowing

Identify provocative movement patterns or technical errors during ergometer rowing and to find alternative movement strategies that allowed them to perform this task in a pain-reduced manner.



(Excessive thoracic extension and lumbar flexion at the catch)

Cognitive Component

Key elements:

- The main aim of this component was to provide patient-centred education regarding the mechanisms that underlie their pain and disability. Addressing negative beliefs and fear regarding pain and radiological findings if present.
- The participant's individual pain and disability provoking factors were outlined in a diagram based on their examination findings, RMDQ and PSFS.
- Use of motivational interviewing techniques, promoting an open reflective discussion about the contributing factors to the rowers' disorder and how they may be able to influence them.

The cognitive component was carried out in conjunction with the other components of the intervention (interview, physical examination and functional component).

Key elements:

1. Movement training and body awareness
2. Functional integration
3. Conditioning training

1. Movement training and body awareness

- This component was behaviorally and cognitively oriented, aimed to provide rowers with alternative strategies to posture and movement, allowing them to move and load their back in a pain-reduced manner.
- Use of visual feedback with mirrors and videos (taken with participant's phone device) to retrain body schema, awareness and control.
- According to the participant's movement ability, they were initially trained to move their thoracic and lumbo-pelvic region independently from each other.
- Once this was achieved, these exercises were progressed targeting functional posture and movement training based on the participant's movement classification and directed by their provocative activities and postures.



Lumbo-pelvic dissociation in crook lying



Lumbo-pelvic and thoraco-lumbar dissociation in sitting (emphasis positioning the spine in neutral posture)



Lumbo-pelvic and thoraco-lumbar dissociation in ergometer rowing



2. Functional integration

- Using the aggravating factors on the PSFS, the physiotherapist trained the rowers to perform the previously pain provocative tasks in a pain-reduced manner.
- In order to reinforce the 'new' movement patterns, the 'old way' and the 'new way' of performing given tasks were outlined in an exercise sheet containing written instructions and drawn body diagrams. Photographs or videos (taken with the participants' phone device) were also utilized. This allowed the

rowers to see their spine during the execution of tasks in the “old” and “new” way of moving, enhancing body schema (awareness).

- These exercises were given to the rowers according to their classification and progressively performed in different functional positions, challenging the rowers to maintain such position in a pain-reduced manner. For example:
 - The rowers were taught to change their pattern of movement to reduce lumbo-sacral flexion during the pain-provocative tasks. The exercises encouraged anterior pelvic tilt and hip flexion during such tasks to reduce end of range lumbar flexion loading.
 - Individual attention was taken to ensure movement training was focused on teaching subjects to adopt spinal postures that were minimally pain provocative. If there was a large loading component (where there was prominent co-contraction of the abdominal and spinal extensor muscles) to the disorder, greater attention was placed on ensuring abdominal bracing was avoided during training.



Sitting with a neutral lumbar posture



Sit and forward reach via hips whilst maintaining lumbar and thoracic neutral



Finish – encourage anterior pelvic rotation and neutral lumbar spine



Mid drive – promote a neutral lumbar spine and thoracic flexion



Catch – promote hip flexion and thoracic flexion

- The exercises were gradually progressed from low load to more complex functional (rowing-specific) exercises as the participant’s gained more confidence and control in performing the tasks. This challenged the rowers to perform previously pain-provocative tasks with pain control. The exercises encouraged them to perform daily life tasks in a new pain-reduced manner.
- When the participant reported difficulty in performing a specific task, this would be addressed by rehearsing it in the clinic under supervision and with the use of visual feedback and demonstration by the physiotherapist. Once the participant was able to perform such tasks in a controlled pain-reduced manner, he was encouraged to include these tasks to his daily activities.

3. CONDITIONING

- In order to allow the rowers to perform their goals with the 'new' movement pattern, the exercises were progressed into a conditioning program to develop strength and endurance within these functional tasks.
- The conditioning exercises were set up in the form of a circuit. This circuit was repeated 3 to 4 times in each session, every second day. The aim of the exercises in this circuit was to improve lower limb and back muscle endurance using functional (rowing-targeted) exercises such as forward reach, sit to stand, squats and single leg squats. These exercises were prescribed according to the rowers' classification and are displayed in the series of figures below.

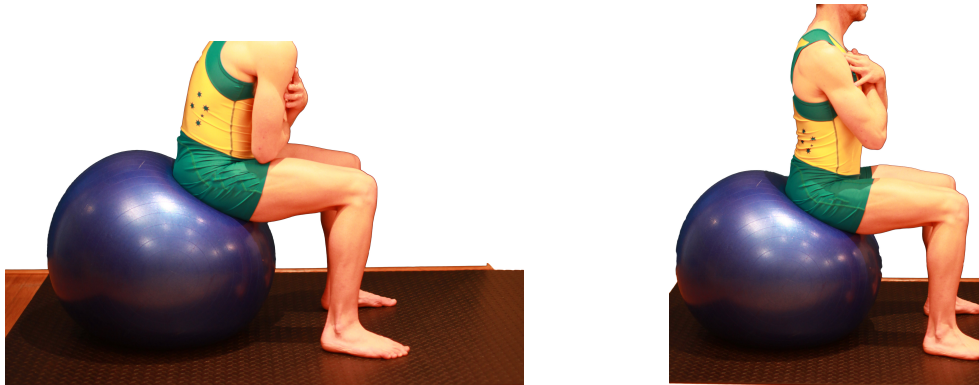

Lumbo-pelvic and thoraco-lumbar dissociation training in sitting.



Lumbo-pelvic and thoraco-lumbar dissociation in row position

Single leg hip flexion hold in row position

Double leg hip flexion hold in row position



Squat with lumbar neutral and relaxed thorax



Lifting with lumbar neutral and relaxed thorax



Single leg sit to stand with lumbar neutral and relaxed thorax



Single leg squat with lumbar neutral and relaxed thorax



Single leg squat with weights - maintaining lumbar neutral and relaxed thorax



Sit up simulating row position. Emphasis on driving the movement from the hips aiming to: maintain lumbar neutral for a large proportion of the stroke, and reproduce “rock over” action in the boat.



Sit up simulating sweep row position. Emphasis on driving the movement from the hips and rotating the trunk towards the inside leg via the upper thorax, inside hip and pelvis.³⁷

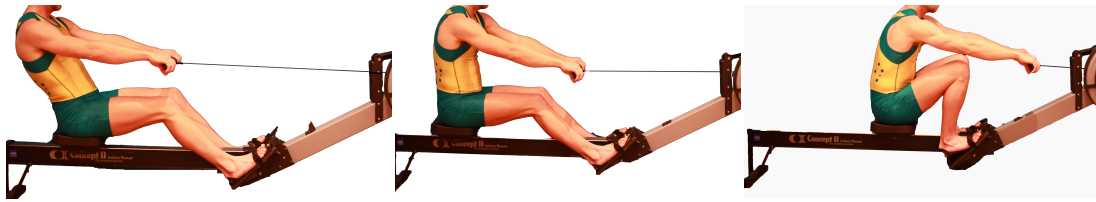

Ergometer rowing drill emphasizing movement from the hips and lumbar neutral through a large proportion of the stroke. The drill was to be performed slowly allowing the rower to perceive the contribution of different parts of the body to the stroke. This was initially practiced with the therapist, then the rowers were encouraged to perform this drill as part of their warm up routine.

- These exercises were progressed according to the individual rower's level of conditioning, but with a goal of reaching 240 repetitions of the exercise within the circuit session. This was based on the average number of strokes needed to accomplish a 2000m rowing race at a reasonable time for this level.

Chapter 8 - Study 6

Cognitive functional therapy for the management of low back pain in an adolescent male rower: a case report

Authors: *JP Cañeiro, *Leo Ng, PT, Angus Burnett, PhD, Amity Campbell, Peter O'Sullivan

*denotes equal contribution to the manuscript

The specific aim for Study 6 was:

- To investigate the efficacy of cognitive functional therapy in reducing low back pain and disability in an adolescent male rower with high pain and disability.

Study 6 was published in *Journal of Orthopaedics & Sports Physical Therapy* 2013. 43(8): 542-549.

Reproduced with permission from Cañeiro JP, Ng L, Burnett A, Campbell A, O'Sullivan PB. Cognitive functional therapy for the management of low back pain in an adolescent male rower: a case report. J Orthop Sports Phys Ther. 2013;43:542-554. <http://dx.doi.org/10.2519/jospt.2013.4699>. Copyright ©Journal of Orthopaedic & Sports Physical Therapy®

8.1 Abstract

Study Design: Case report

Background: Contemporary low back pain (LBP) models propose that the experience of and responses to pain result from a complex interaction of bio-psycho-social factors. This supports the need for a management approach that addresses the biological, psychological and social components that may be related to the pain disorder. This case report demonstrates the application of, and outcomes associated with, a cognitive functional intervention that considers neurophysiological, physical, psychosocial, cognitive and lifestyle dimensions for the management of a rower with non-specific chronic LBP.

Case Description: An adolescent male club-level rower with non-specific LBP was classified as having a motor control impairment with a lower lumbar *compressive loading pattern in flexion*. Evaluation of this patient included ergometer rowing analysis (clinical and laboratory) before and after an 8-week intervention, and outcome measures at a 12-week follow-up. The intervention consisted of a cognitive functional approach, which targeted optimisation of movement behaviour, providing the rower with alternative movement strategies to minimise sustained flexion loading.

Outcomes: Reduced temporal summation of pain while ergometer rowing and reduced functional disability were observed baseline to 12-weeks follow-up by changes in Roland Morris Disability Questionnaire score (12/24 to 1/24) and the Patient Specific Functional Scale (4/30 to 26/30), and associated improvements in lower limb and back muscle endurance and changes in hip and spino-pelvic kinematics during ergometer rowing. In particular, there was a greater use of available range of movement in the lumbar spine post intervention.

Discussion: The cognitive functional intervention for this patient resulted in reduced pain and functional disability related to ergometer rowing, which was associated with a change in lumbar kinematics and improved lower limb and back muscle endurance. The results suggest that providing the rower with greater use of his available range of movement may enhance load distribution during the drive phase of rowing. Registered at Australian New Zealand Clinical Trials Registry (ACTRN12609000565246).

Level of Evidence: Therapy, Level 4

Key words: low back pain in sports, spino-pelvic kinematics; motor control impairment

8.2 Introduction

Low back pain (LBP) is a common complaint amongst rowers.^{4,18,39,47,50,58}

Research has suggested that there is a higher prevalence of LBP in elite male rowers, with 25% of total injuries reported in the low back, compared to 15.2% in female rowers.¹⁸ Adolescent rowers also appear to be at particular risk, with up to 47.5% of schoolgirl rowers reporting back pain and higher levels of disability compared to 15.5% of age-matched controls,³⁹ suggesting that rowing related factors are associated with pain and disability.³⁹

Previous research has found that rowers with LBP reported a gradual increase of pain during ergometer rowing.³¹ It has also been reported that rowers with LBP maintain their lumbar spine posture closer to end range flexion and use less of their available range across the drive phase when compared to rowers without pain.³¹ It is proposed that these motor control patterns could be maladaptive and pain provocative, resulting in sustained flexion loading (i.e., strain) to the lumbar spine which may in turn, lead to pain.³⁴ Patients with LBP have been reported to present with altered movement patterns and body schema, which raises the possibility that retraining movement patterns through interventions that address both cognitive and functional domains may assist with managing chronic spinal pain.^{24,29,36,56} However, to date it is not known whether targeted interventions are able to influence these patterns.

It has been proposed that accurate diagnosis and classification of a LBP disorder (based on neurophysiological, physical behavioural, psychosocial and lifestyle factors), is required to allow targeted interventions directed at the mechanisms that underlie such a disorder.^{12,13,15,34-36,55} O'Sullivan (2005) proposed a management approach for chronic LBP based on a multi-dimensional classification system called cognitive functional therapy (CFT).³⁴⁻³⁶ The CFT approach involves addressing cognitive, functional and lifestyle aspects of the disorder. The key elements of the cognitive component involve: addressing negative beliefs and fear regarding pain and MRI findings; patient centred education regarding the mechanisms that drive their vicious cycle of pain and disability; raising awareness of the body-mind

responses to pain, movement and their perceived threat. The functional component is behaviourally orientated and involves: retraining body schema (awareness) with the use of visual feedback, normalising provocative movement patterns and pain behaviours in a graduated manner directed towards the patient's functional goals; strengthening and conditioning of the normalised movement pattern.^{15,36} A study involving 82 adolescent female rowers with and without LBP demonstrated that a CFT approach was associated with a reduction in the prevalence of LBP across the season (from 48% to 24%) and reduced pain intensity levels in subjects who complained of LBP at the commencement of the rowing season.⁵¹ LBP was also reduced in a group of adolescent female rowers whose static and dynamic rowing postures were targeted with a similar cognitive functional intervention.⁴⁰ However, to date no studies have confirmed whether this intervention may successfully alter spinal kinematics during rowing, or result in changes in pain response during rowing. Furthermore, given that spinal kinematics differ between genders and males appear to be more susceptible to LBP, previously successful interventions should be evaluated in the male population.^{18,27,33} The aim of this case study was to investigate whether a CFT intervention could alter the spinal kinematics and reduce the LBP of a adolescent male rower during ergometer rowing.

8.3 Case description

A sports physiotherapist, who had a post-graduate qualification and 5 years experience with the Australian rowing team, performed an interview and a clinical examination. The physiotherapist was blinded to the laboratory data.

A 17-year-old male rower (height, 1.85m; weight, 86kg), in his fourth year of amateur club rowing competition was recruited for this study. Written informed consent was obtained from the rower and his parent (appendix P), permission to conduct the laboratory testing and treatment protocol was granted by the Curtin University Human Research Ethics Committee (HR 197/2008) (appendix O). At the time of recruitment, the rower reported a 4-month history of LBP that initially occurred only at the end of rowing

sessions. This progressed to pain provoked by gym sessions, sitting at school and light home duties. A magnetic resonance imaging scan of the lumbar spine was organized by the local physiotherapist and showed no radiological abnormalities. A previous rehabilitation program designed by the patient's physiotherapist, which included rest from rowing, stretches of the hamstring muscles, 'core stability strategies' and lower back muscle strengthening, did not have a positive effect. Within 3 months, the patient reported that his LBP had worsened, which prevented him from participating in any form of rowing training. Prior to his first episode of LBP, he had previously trained between 17 to 18 hours a week, and had been competing in regular rowing regattas.

During the clinical interview, the rower reported feeling a localised deep ache with an intensity of 6/10 on the Visual Analogue Scale (VAS) at the lower lumbar region. This pain became sharp/catching pain (VAS 8/10) with movement. There was no peripheralisation of the symptoms, and the pain did not affect his sleep. The aggravating factors included: *postures* (sitting; sustained bending) and *activities* (rowing ergometer; stationary cycling; bending; lifting; loaded exercises in the gym). Avoidance of provocative activities and stretching hamstring and back muscles helped to ease the pain. When asked, the patient believed that: 1) He would get better with an appropriate exercise program, and 2) Rowing was likely to aggravate his back pain. He reported that his pain during rowing was aggravated by trying to achieve a more upright posture (sitting tall throughout the stroke, especially at the catch) and eased by adopting a more rounded thoracic posture. Ironically, even though he reported that the rounded thoracic posture alleviated his symptoms, he believed this posture was not good for his back due to the postural advice he had been given. The patient's past medical history was unremarkable. The athlete's goals were to return to exercise and crew rowing.

Clinical Examination and Findings

Clinical observation of the athlete's usual sitting posture revealed: thoracic upright sitting posture (flexed lumbar spine and extended thoracic spine).³⁸ Analysis of his movement patterns allowed the therapist to identify the athlete's full available spinal range of movement. Observation of forward bending revealed full range of movement with self-reported pain throughout (VAS 6/10). Through palpation of the trunk muscles, the physiotherapist was able to identify that both the abdominal and paraspinal muscles were actively tense (firm resistance to palpation) during bending suggesting that the patient was co-contracting these muscles during the movement. The rower initiated forward bending through the lumbar region with delayed anterior pelvic rotation, and initiated return to an upright position via the thoracic spine, propping his hands on his thighs. The rower demonstrated full range of backward and bilateral side bending with no pain. Modification of forward bending was instigated by: instructing the rower to relax the trunk muscles during bending by facilitation of thoracic flexion with a relaxed abdominal wall (no breath holding), bending with more anterior pelvic rotation, slight knee flexion and returning to upright via the hips while relaxing the thoraco-lumbar spine.^{12,34} The rower reported a significant reduction of back pain (VAS 2/10). Analysis of functional tests demonstrated that the athlete assumed an extended thoraco-lumbar spine posture (observable reduction of lumbar lordosis and increase in lordosis in the upper lumbar and lower thoracic spine) when squatting or performing a sit to stand task.^{9,37} Co-contraction of the paraspinal and abdominal muscles was again detected by palpation during the execution of these tasks. Specific movement tests undertaken by the rower and observed by the physiotherapist revealed poor thoraco-lumbar and lumbo-pelvic dissociation; especially when sitting on the rowing ergometer, suggesting the athlete's inability to move the thorax, the lumbar spine, and the pelvis independently.^{9,37}

Clinical observation during ergometer rowing revealed that the rower maintained a stiff thoraco-lumbar spine throughout the rowing stroke. It was also observed that he initiated the drive phase with thoracic spinal extension, followed by early elbow flexion and late lower limb extension. Palpation of the

trunk muscles during ergometer rowing revealed co-contraction of the abdominal muscles (Figure 8.1). He reported a pain intensity of 6/10 during ergometer rowing. Modification of these movement patterns, involving; relaxed thoraco-lumbar flexion throughout the stroke (utilising a greater proportion of his full available range of movement); early extension of the lower limb and delayed flexion of the upper limb during drive phase, resulted in reduced self reported pain during ergometer rowing (VAS 2/10).³⁴

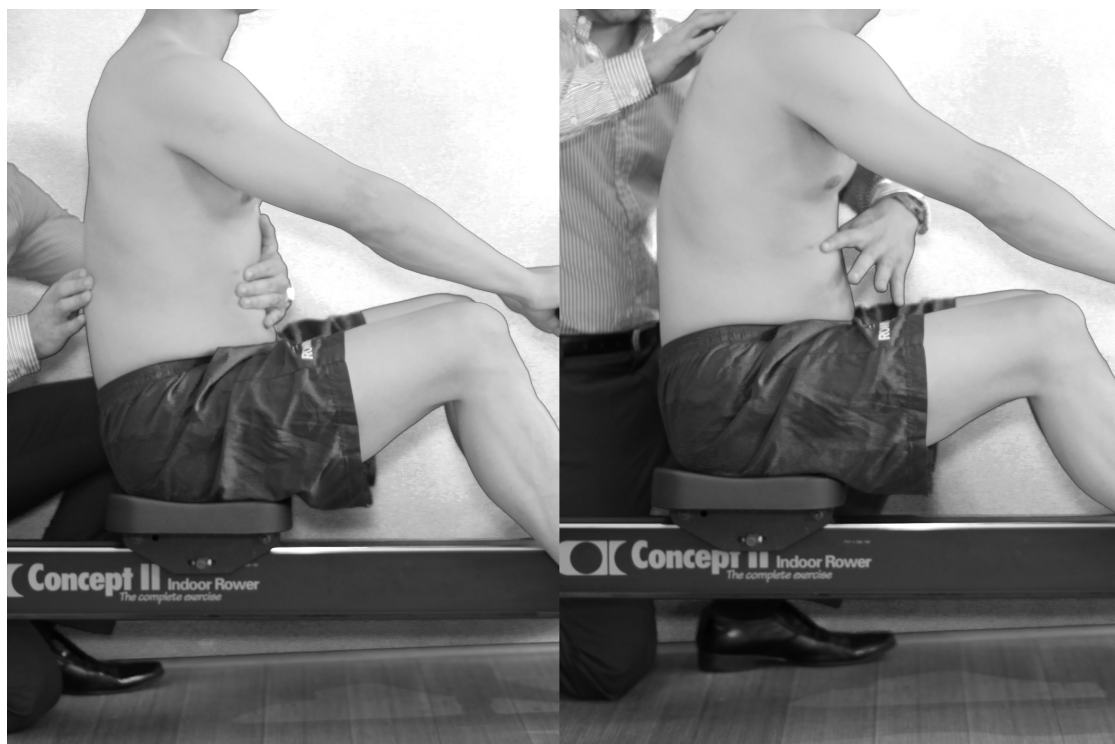

Co-Contracted Trunk

Relaxed Trunk

Figure 8.1 - This figure provides a comparison between the athlete's usual movement strategy (upright/rigid posture with co-contracted trunk muscles) and the new movement strategy (relaxed thoraco-lumbar region and relaxed trunk muscles) during ergometer rowing

Neurological screening was unremarkable,¹⁷ with absence of adverse neurological (reflexes, sensation and power) or neural provocation findings. Passive physiological motion segment testing was normal.²⁵ Palpation of the lumbar spine was able to reproduce the athlete's pain through central palpation of L4/L5 and L5/S1 segments.²⁵ It also revealed the presence of pain over lumbar erector spinae (ES) and quadratus lumborum (QL).

Clinical Reasoning

Based on the interview, physical examination findings and the absence of specific pathology (as assessed by magnetic resonance imaging), this patient was diagnosed with non-specific chronic LBP, consistent with repetitive loading, and bending strain of the lower lumbar spine. The disorder was chronic (greater than 3 months in duration) and progressive according to the classification system as described by O'Sullivan.^{12,15,34-37} The disorder was classified as a primary maladaptive motor control impairment with a compressive-loading pattern (flexion bias) at the lower lumbar spine.^{11,34,35}

The classification encompassed several dimensions:

1. Neurophysiological: dominant nociceptive with peripheral sensitisation as the pain was localised, had a clear mechanical behaviour and was amenable to change.
2. Physical behaviours: The key feature that led to this classification was LBP associated with flexion-loading activities. The patient presented with full active range of motion but utilised co-contraction of trunk muscles during bending tasks. Modification of the functional tasks via reduced trunk muscle co-contraction resulted in pain reduction.
3. Psycho-social and cognitive: The patient presented with avoidant coping strategies such as stopping training and rest, as reported in his clinical interview, and a belief that holding the spine upright and bracing his abdominal wall was positive for his back, a lack of awareness of his body schema and the mechanisms associated with his LBP, social isolation from sport and friends.
4. Lifestyle: physical deconditioning associated with activity avoidance.

Figure 8.2 displays the clinical reasoning used in this case report in a schematic manner.

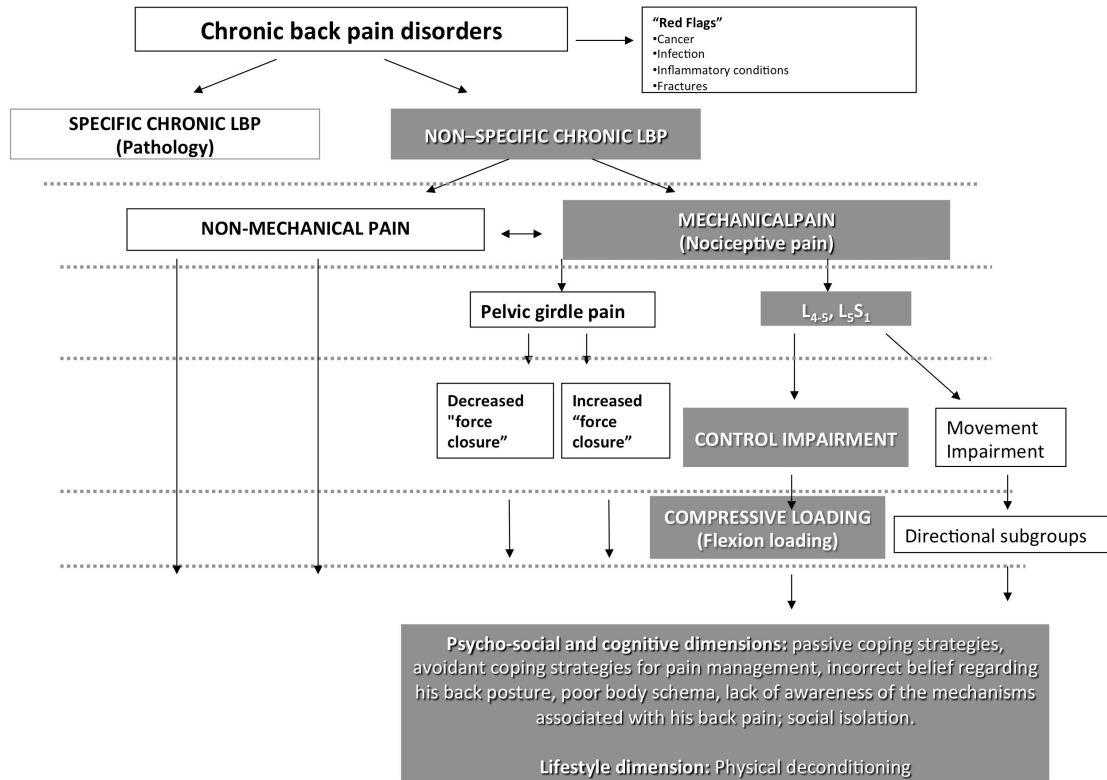

Figure 8.2 - Flow chart describing the different levels of the Multidimensional Classification System (Adapted from O’Sullivan 2012; Fersum et al 2012; Fersum 2009; O’Sullivan 2004, 2005, 2011; Dankaerts et al, 2006, 2009)

*Highlighted areas display the classification assigned for the patient in this case report

8.4 Outcome Measures

Outcome measure data were collected at baseline, 8-week follow-up, and a 12-week follow-up. The primary outcomes for this study were the rower’s self reported pain measured by the Numeric Pain Rating Scale (NPRS), and disability measured by the Roland Morris Disability Questionnaire (RMDQ) and the Patient Specific Functional Scale (PSFS). The primary outcome

measures were collected by a researcher who was blinded to the intervention as part of a larger randomised controlled trial (ACTRN12609000565246).

Numeric Pain Rating Scale (NPRS) The NPRS is an 11-point scale (0-10) of self-reported pain intensity with a minimum clinically significant difference of 2.⁷ The NPRS was administered verbally for each minute during a 15-minute ergometer trial, at baseline and 8-week follow-up.

Roland Morris Disability Questionnaire (RMDQ): The RMDQ is a disability measure that it is widely used in LBP studies with a score of zero representing no disability and a score of 24 maximal disability (appendix M).⁴⁴ A difference of 2.5 points in RMDQ change scores is considered to be the minimum clinically important difference.⁴⁵

Patient Specific Functional Scale: To quantify self-reported functional disability, the Patient Specific Functional Scale (PSFS) was selected (appendix N). In this scale, 0 represents maximal disability and 10 represents no disability for each activity chosen by the participant.⁴⁹ This outcome measure has a minimal clinical significant difference of 3 for one activity and 2 for the average of more than 1 activity.⁴⁹ This rower chose rowing, lifting weights and forward bending as the 3 activities most affected by his LBP.

The secondary outcomes for this study included hip, pelvic and trunk kinematics, which were collected by the researcher who was blinded to the intervention. Furthermore, isometric muscle testing of the erector spinae, quadriceps and the hip flexors were collected by the sports physiotherapist as part of the physical examination.

Hip, pelvic and trunk kinematics: Kinematics during a 15-minute ergometer row were collected at pre-intervention and post-intervention data collection using the 3-Space Fastrak™ system (Polhemus Navigation Science Division, Kaiser Aerospace, Vermont). This has been shown to be a valid tool to collect kinematics during ergometer rowing, with an error of 0.4° when used on a modified ergometer and has been used in other rowing related

studies.^{32,48} A detailed description of this process is described in the laboratory analyses section of this paper.

Back muscle endurance (BME): To determine this rower's level of BME, the Biering-Sorenson's test was used.² This test has been shown to be valid and reliable in adolescents.^{1,46} Adolescent rowers with LBP have been reported to perform significantly worse in this test compared to age matched pain free rowers.⁴¹

Lower limb muscle endurance (LLME): The isometric squat and hip flexor muscle test were described to be part of assessment to classify patients with nonspecific chronic LBP.^{1,37} It has been postulated that poor LLME may be associated with compensatory spinal movement patterns.³⁷ Evidence has shown that adolescents with LBP demonstrate poorer squat and hip flexor muscle test results compared to adolescents without LBP in the general population¹ and in rowers.⁴¹

Sit and Reach Test: This test has been widely used to determine the flexibility of the hamstrings and back.²³ Lack of hamstring flexibility has been reported as one of the individual risk factors for LBP in rowers.^{40,42}

Table 8.1 – Outcome measures and kinematics data at baseline, 8-week follow-up and at 12-week follow-up

	Baseline	8-week follow-up	12-week follow-up
RMDQ	12/24	1/24	1/24
PSFS			
Rowing	1/10	9/10	9/10
Lifting weights	0/10	8/10	8/10
Forward Bending	3/10	9/10	9/10
Physical Assessments	30	65	80
Biering Sorensen (s)			
Sit and Reach (m)	-0.12	0.0	0.0
Squat Hold (s)	20	90	120
Hip Flexor Hold (s)	12	45	60
Usual Sitting			
SA	-0.5°	8.9°	
LLC	2.5°	-3.8°	
ULC	20.6°	-12.5°	
LC	23.1°	-14.6°	
Stroke Length			
1 st minute	1.45m	1.44m	
Range between catch and finish			
1 st minute			
SA	36.4°	26.3°	
LLC	5.5°	23.5°	
ULC	4.0°	11.3°	
LC	9.5°	13.9°	
Hip	71.4°	73.9°	
Percentage of stroke in drive phase			
1 st minute	33.7%	38.3%	

Laboratory Analyses

Motion analysis testing was performed on a modified rowing ergometer³² in the pre-intervention laboratory analysis and post-intervention laboratory analysis using the 3-Space Fastrak™ system at 25 Hz (Polhemus Navigation Science Division, Kaiser Aerospace, Vermont).⁴⁸ Four electromagnetic sensors were secured onto the participants' skin overlying the mid femur, and the S2, L3 and T12 spinous processes using double sided tape and Fixomull®. A rotary encoder was also connected to the flywheel of the rowing ergometer to determine the stroke length. The voltage generated by the

rotary encoder was calibrated with a ruler prior to each trial to determine stroke length and was synchronised with the 3-Space Fastrak™ (Polhemus) using a customised Labview software program (Version 8.6.1, National Instruments, Austin, TX). The following angles were calculated from the 3-Space Fastrak™ data using customised Labview software (Version 8.6.1, National Instruments, Texas, USA).⁵ and have been used in previous studies of rowing kinematics^{30,32,48} (figure 8.3):

- Hip Angle (HA) – angle of the S2 sensor relative to the femur sensor.
- Pelvis Angle (PA) – angle of the S2 sensor relative to the vertical axis.
- Lower Lumbar Angle (LLA) – angle of the L3 sensor relative to the S2 sensor.
- Upper Lumbar Angle (ULA) – angle of the T12 sensor relative to the L3 sensor and.
- Lumbar Angle (LA) – angle of the T12 sensor relative to the S2 sensor.

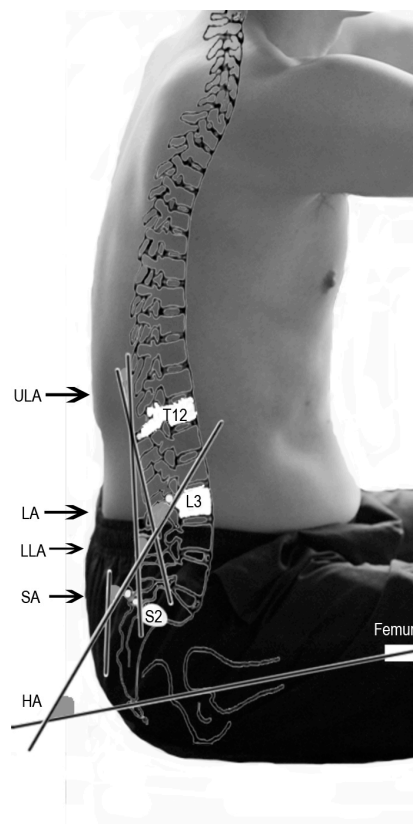

Figure 8.3 - Hip, pelvic and trunk kinematics (ULA – Upper Lumbar Angle; LA – Lumbar Angle; LLA – Lower Lumbar Angle; SA – Sacral Angle; HA – Hip Angle)

Only sagittal planes angles were reported as only movements in this plane provoked pain and movements in the frontal and transverse planes during a centre-pulled ergometer rowing trial are minimal.⁴⁸ A hip angle of 0° reflected a straight alignment between the S2 sensor and the femur sensors. For trunk kinematics and pelvic angles, positive values represented trunk flexion and anterior pelvic tilt for the pelvis, and negative angles represented trunk extension and posterior pelvic tilt of the pelvis. Only drive phase data were analysed, and were normalised to time from the beginning of the drive phase (catch) to the end of the drive phase (finish). The drive phase is defined as the period during which the rower moves from the maximum forward reach to the maximum backwards lean during ergometer rowing.

Laboratory Testing Protocol

The rower first performed a usual-sitting test, where he replicated his usual day-to-day sitting posture. He then completed a warm up of 5 minutes of sub-maximal ergometer rowing. During the rowing trial, the rower was requested to row at a very high intensity (17/20) on the rate of perceived exertion (RPE) (see appendix K) at a stroke rate of 22 strokes per minute for a period of 15 minutes. This protocol has been used in previous studies,³¹ and was determined after consultations between the research team and coaches. During the ergometer trial, the RPE³ and the NPRS⁷ were verbally collected at the beginning of every minute of the ergometer trial and also at the end of the 15-minute ergometer trial. RPE was used only to standardise output during ergometer rowing, and the result of the NPRS is presented in Figure 8.4.

8.5 Intervention

Based on the clinical reasoning described above, a CFT approach was employed to address the disorder. A detailed description of the rower's intervention is presented in the appendix. This intervention was conducted by the sports physiotherapist who was blinded from the outcome measures data. The intervention was delivered during 5 individual sessions over a duration of 8 weeks, between baseline and post-intervention data

collection.^{13,15,34-36,51} The program was tailored to the patient's goal of enhancing his capacity to row without back pain. The intervention was composed of 2 major components, a cognitive component and a functional component (supplementary material 8.11).

1. Cognitive Component – The cognitive component consisted of education regarding pain mechanism (a vicious cycle of pain, as outlined in a diagram based on his findings from the examinations, RMDQ and PSFS); using the patient's interview and physical findings to challenge the patient beliefs regarding his pain.

2. Functional Component – The functional component was behaviourally and cognitively orientated to train body awareness (with the use of mirrors and videos) and to provide alternative strategies to normalise the rower's postural and movement patterns allowing him to confront activity avoidance by moving in a pain free manner. This component included: posture and movement retraining; lower limb and back muscle endurance training in row specific postures; exercises and movement modification were integrated into a rowing specific routine in order to return the athlete to his sport in a graduated manner (supplementary material 8.11).

The rower was also asked to fill in a compliance sheet to indicate the level of adherence to the program. From inspecting this sheet he was deemed to have a high level of compliance by the treating physiotherapist.

8.6 Outcomes

This rower showed an improvement in the primary outcome measures following an 8-week physiotherapy intervention. The NPRS (Figure 8.4) revealed a reduction in the intensity of the temporal summation of pain demonstrated during ergometer rowing. The results of the RMDQ and PSFS (Table 8.1) also supported a reduction in disability.

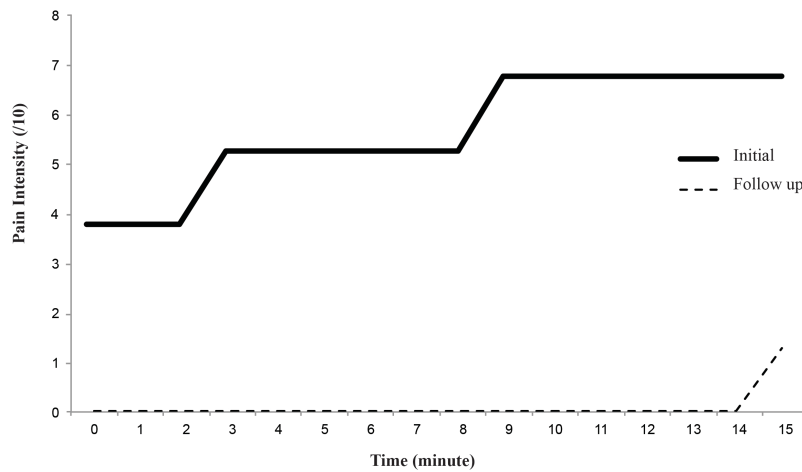

Figure 8.4 - NPRS during ergometer rowing at pre-intervention laboratory analysis (baseline) and post-intervention laboratory analysis (8-week follow up)

The secondary outcomes for this study demonstrated a change in trunk, pelvis and lumbar kinematics during rowing following the intervention (Figure 8.5). The kinematics data indicate that the athlete rowed with greater hip flexion throughout; placed the pelvis in more posterior pelvic tilt, and had a greater range of movement throughout the drive phase (demonstrated by greater range of LLA and greater angle and less flexion in the ULA) following the 8-week intervention. Although kinematic data of 3 completed rowing strokes were collected during the last 15 seconds of every minute, only the kinematic data of the first minute are presented in figure 8.5. The percentage of the stroke in the drive phase was also increased following intervention (Table 8.1). Furthermore, there were improvements in the physical assessments following the intervention in the Biering-Sorensen's test, sit and reach test, squat hold and the hip flexor hold (Table 8.1).

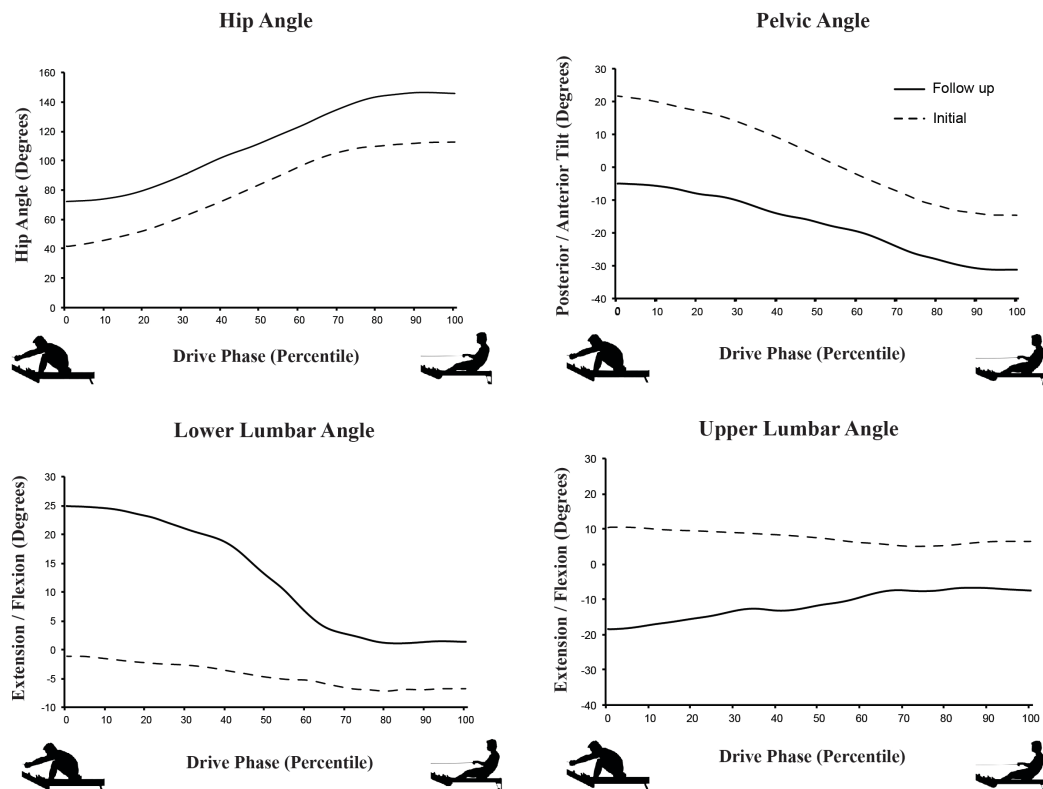

Figure 8.5 - Hip, pelvic and trunk kinematics of the drive phase during the 1st minute of the rowing ergometer trial.

Where positive angles indicate flexion angles (anterior pelvic tilt of the SA) and negative angles indicate extension angles (posterior pelvic tilt). Dotted lines represent the pre-intervention kinematics (Initial) and solid lines represent the post-intervention kinematics (Follow up)

8.7 Discussion

The results of this case study support an association between a cognitive functional approach to managing and reducing pain and disability in an adolescent male rower during ergometer rowing. After the intervention the athlete demonstrated a clinically significant improvement in pain and more importantly, a reduction in the intensity of pain ramping (temporal summation) during ergometer rowing.

The reduction in pain and disability in this rower was associated with observed changes in spino-pelvic kinematics, increased back and hip muscle endurance and increased sit and reach flexibility. Post-intervention, the kinematic data revealed the rower utilised a greater proportion of his available range of movement in the lower lumbar spine (Figure 8.5). It is

possible that the intervention provided this athlete with an alternative movement strategy and enhanced load distribution across the lumbar spine, thereby reducing focal strain and loading of the lower lumbar region (area of pain).^{9,14,34,53,54} Another possible interpretation is that the rower developed greater load tolerance due to the rowing-specific conditioning. It is also possible that the intervention reduced his fear of back loading, by reframing his beliefs about pain and teaching adaptive movement strategies related to rowing.

Although trunk muscle activation was not measured (for example using electromyography data) it is postulated that this athlete presented with a compressive loading disorder with a bias towards flexion loading,³⁴ that was driven by increased trunk muscle co-contraction (detected on clinical examination) and resulted in reduced use of lumbar range of motion during ergometer rowing. O'Sullivan proposed that adopting maladaptive movement patterns associated with trunk muscle co-contraction may lead to non-physiological loading of the lumbar spine (not end range) during loading tasks (e.g. rowing).³⁴ This observation is consistent with suggestions that some individuals with nonspecific chronic LBP may have greater trunk muscle co-activity compared to asymptomatic individuals during trunk movements in the frontal, sagittal,¹⁰ and transverse^{20,52} planes of movement. Furthermore, increases in trunk muscle activity have been associated with greater trunk stiffness.²⁸ Future studies employing EMG will be able to determine the veracity of these hypotheses.

This case study assessed an intervention aimed at optimising cognitive and movement behaviours, in order to provide an adolescent male rower with alternative coping and movement strategies, allowing him to gain strength and conditioning in a non-provocative and relaxed manner. This approach included a strong cognitive component aimed at: changing his beliefs regarding the need to hold his thorax erect and brace his spine, as well as the use of visual feedback through mirrors and videos targeting visualisation of movement in order to retrain body schema⁵⁷ and to reduce sense of threat.⁸ Although speculative, a combination of factors such as postural

changes, improvement in conditioning and flexibility, improvement in confidence,¹⁶ improvement in body awareness,^{29,56} reduced sense of threat⁸ and more relaxed movement patterns^{34,53} might have enabled this athlete to resume rowing training with significantly lower levels of pain.

Consistent with these findings, similar cognitive functional approaches have been applied in populations of cyclists^{6,53,54} and female rowers.^{40,51} More specifically, a similar cognitive functional intervention was shown to reduce summation of pain in a cyclist with nonspecific chronic LBP during a two hour outdoor cycling task.⁵³ This study also found a relationship between clinical changes (reduced pain and disability) and a change in spino-pelvic kinematics whilst rowing. Similar to Van Hoof et al,⁵⁴ we reported abolishment of the phenomenon of summation of pain in an athlete with nonspecific chronic LBP while performing a functional task.

This case report challenges the popular beliefs that chronic LBP should be managed by training neutral postures and enhancing greater core stability.^{19,21,22,43} The rower in this case study presented with a reduced use of his available spinal movement pattern during ergometer rowing prior to the intervention. Whether this movement pattern had been reinforced by the prior stability training program is not known although he reported that this approach led to an increase in his levels of pain and disability. In contrast, following the cognitive functional approach he demonstrated more lumbar flexion and greater flexibility during the drive phase.

The authors acknowledge potential limitations of this study. The study design is that of a single case study, and therefore it cannot be concluded that the success of the current intervention would be relevant for other rowers. Rather, the purpose of this study was to support the outlined systematic approach to individually classify athletes with chronic LBP and develop a targeted intervention for this condition. Performance was not assessed in this study, as the goal of the treatment, as defined by the rower was to return to rowing at any level. Although palpation is widely used by physical therapists during clinical examinations,²⁶ the validity and reliability to identify active

muscle contraction (tension) during static and dynamic postures have not been reported, limiting the replication of this test. Quantitative kinetic information and electromyography should also be included in future studies. The test-retest reliability of the Fastrak™ motion analysis system utilised during ergometer rowing was not assessed during this study and may be subject to soft tissue artifact errors. Future studies should include a randomised controlled trial with more participants of different genders and levels of participation (i.e. social to elite).

8.8 Conclusion

The results of this study indicate that a cognitive functional intervention appeared to be successful in reducing pain and disability related to rowing in an adolescent male rower. This was associated with greater range of spinal movement during ergometer rowing, increased back and hip muscle endurance and increased flexibility.

8.9 Acknowledgement

This study was supported by research grants from the Physiotherapy Research Foundation tagged Sports Physiotherapy Australia grant as part of a randomised controlled clinical trial (T09-THE/SPA001). The authors would also like to acknowledge the help of Paul Davey for his assistance.

8.10 References

1. Astfalck RG, O'Sullivan PB, Straker LM, Smith AJ. A detailed characterisation of pain, disability, physical and psychological features of a small group of adolescents with non-specific chronic low back pain. *Manual Therapy*. 2010;15(3):240-247.
2. Beiring-Sorenson F. Physical measurements as risk indicators for low back trouble over a one year period. *Spine*. 1984;9(2):106-119.
3. Borg G. Perceived exertion as an indicator of somatic stress. *Scandinavian Journal of Rehabilitative Medicine*. 1970;2(3):92-98.
4. Budgett RG. The road to success in international rowing. *British Journal of Sports Medicine*. 1989;23(1):49-50.
5. Burnett AF, Barrett CJ, Marshall RN, Elliott BC, Day RE. Three-dimensional measurement of lumbar spine kinematics for fast bowlers in cricket. *Clinical Biomechanics*. 1998;13(8):574-583.
6. Burnett AF, Cornelius MW, Dankaerts W, O'Sullivan PB. Spinal kinematics and trunk muscle activity in cyclists: a comparison between healthy controls and non-specific chronic low back pain subjects - a pilot investigation. *Manual Therapy*. 2004;9(4):211-219.
7. Cole B, Finch E, Gowland C, Mayo N. *Physical rehabilitation outcome measures*. Baltimore: Williams and Wilkins; 1995.
8. Crombez G, Eccleston C, Van Damme S, Vlayen J, Karoly P. Fear-avoidance model of chronic pain the next generation. *Clinical Journal of Pain*. 2012;28(6):475-483.
9. Dankaerts W, O'Sullivan P, Burnett A, Straker L. Differences in sitting postures are associated with nonspecific chronic low back pain disorders when patients are subclassified. *Spine*. 2006;31(6):698-704.
10. Dankaerts W, O'Sullivan P, Burnett A, Straker L, Davey P, Gupta R. Discriminating healthy controls and two clinical subgroups of nonspecific chronic low back pain patients using trunk muscle activation and lumbosacral kinematics of postures and movements: a statistical classification model. *Spine*. 2009;34(15):1610-1618.
11. Dankaerts W, O'Sullivan PB, Burnett AF, Straker LM. The use of a mechanism-based classification system to evaluate and direct management of a patient with non-specific chronic low back pain and

motor control impairment - a case report. *Manual Therapy*. 2007;12(2):181-191.

12. Dankaerts W, O'Sullivan PB, Straker LM, Burnett AF, Skouen JS. The inter-examiner reliability of a classification method for non-specific chronic low back pain patients with motor control impairment. *Manual Therapy*. 2006;11(1):28-39.
13. Fersum KV, Dankaerts W, O'Sullivan PB, Maes J, Skouen JS, Bjordal JM, et al. Integration of subclassification strategies in randomised controlled clinical trials evaluating manual therapy treatment and exercise therapy for non-specific chronic low back pain: a systematic review. *British Journal of Sports Medicine*. 2010;44(14):1054-1062.
14. Fersum KV, O'Sullivan F, Skouen JS. Inter-examiner reliability of a classification system for patients with non-specific low back pain. *Manual Therapy*. 2009;14(5):555-561.
15. Fersum KV, O'Sullivan P, Skouen JS, Smith A, Kvale A. Efficacy of classification-based cognitive functional therapy in patients with non-specific chronic low back pain: A randomized controlled trial. *European Journal of Pain*. 2012.
16. Gatchel RJ, Peng YB, Peters ML, Fuchs PN, Turk DC. The biopsychosocial approach to chronic pain: scientific advances and future directions. *Psychological Bulletin*. 2007;133(4):581-624.
17. Hall ED, Gibson TR, Pavel KM. Lack of a gender difference in post-traumatic neurodegeneration in the mouse controlled cortical impact injury model. *Journal of Neurotrauma*. 2005;22(6):669-679.
18. Hickey GJ, Fricker PA, McDonald WA. Injuries to elite rowers over a 10-yr period. *Medicine & Science in Sports & Exercise*. 1997;29(12):1567-1572.
19. Hides JA, Jull GA, Richardson CA. Long term effects of specific stabilizing exercises for first-episode low back pain. *Spine*. 2001;26(11):E243-248.

20. Hodges P, van den Hoorn W, Dawson A, Cholewicki J. Changes in the mechanical properties of the trunk in low back pain may be associated with recurrence. *Journal of Biomechanics*. 2009;42(1):61-66.
21. Hodges PW. Core stability exercise in chronic low back pain. *Orthopaedic Clinics of North America*. 2003;34(2):245-254.
22. Ikeda DM, McGill SM. Can altering motions, postures, and loads provide immediate low back pain relief: a study of 4 cases investigating spine load, posture, and stability. *Spine*. 2012;37(23):E1469-1475.
23. Jackson AW, Baker AA. The relationship of the sit and reach test to criterion measures of hamstring and back flexibility in young females. *Research Quarterly for Exercise and Sport*. 1986;57(3):183-186.
24. Luomajoki H, Moseley GL. Tactile acuity and lumbopelvic motor control in patients with back pain and healthy controls. *British Journal of Sports Medicine*. 2009;26(4):339-350.
25. Maitland GD. *Vertebral Manipulation*. 5th ed. London: Butterworths; 1986.
26. May S, Littlewood C, Bishop A. Reliability of procedures used in the physical examination of non-specific low back pain: a systematic review. *The Australian Journal of Physiotherapy*. 2006;52(2):91-102.
27. McGregor AH, Patankar ZS, Bull AMJ. Do men and women row differently? A spinal kinematic and force perspective. *Proceedings of the Institution of Mechanical Engineers. Part P, Journal of sports engineering and technology*. 2008;222(2):77-83.
28. Moorhouse KM, Granata KP. Trunk stiffness and dynamics during active extension exertions. *Journal of Biomechanics*. 2005;38(10):2000-2007.
29. Moseley GL. Pain, brain imaging and physiotherapy - opportunity is knocking. *Manual Therapy*. 2008;13(6):475-177.

30. Ng L, Burnett A, O'Sullivan P. Gender differences in motor control of the trunk during prolonged ergometer rowing. *26th International Conference on Biomechanics in Sports*; July 14-18, 2008; Seoul, South Korea.
31. Ng L, Burnett A, O'Sullivan P. Spino-pelvic kinematics and trunk muscle activation in prolonged ergometer rowing: mechanical etiology of non-specific low back pain in adolescent rowers. *26th International Conference on Biomechanics in Sports*; July 14-18, 2008; Seoul, South Korea.
32. Ng L, Burnett A, O'Sullivan P, Campbell A. Caution: The use of an electromagnetic device to measure trunk kinematics on rowing ergometers. *Sports Biomechanics*. 2009;8(3):255-259.
33. Ng L, Campbell AC, Burnett A, O'sullivan P. Gender differences in trunk and pelvic kinematics during prolonged ergometer rowing in adolescents. *Journal of Applied Biomechanics*. 2013;29(2):180-187.
34. O'Sullivan P. Diagnosis and classification of chronic low back pain disorders: Maladaptive movement and motor control impairments as underlying mechanism. *Manual Therapy*. 2005;10(4):242-255.
35. O'Sullivan P. It's time for change with the management of non-specific chronic low back pain. *British Journal of Sports Medicine*. 2011;46(4):224-227.
36. O'Sullivan P. A classification-based cognitive functional approach for the management of back pain. *Journal of Orthopaedic & Sports Physical Therapy*. 2012;42(10):A17-A21.
37. O'Sullivan PB. 'Clinical instability' of the lumbar spine: its pathological basis, diagnosis and conservative management In: Jeffrey D. Boyling, Nigel Palastanga, eds. *Grieve's modern manual therapy: the vertebral column*. Edinburgh ; New York: Churchill Livingstone; 2004.
38. O'Sullivan PB, Grahamslaw KM, Kendell M, Lapenskie SC, Moller NE, Richards KV. The effect of different standing and sitting postures on trunk muscle activity in a pain-free population. *Spine*. 2002;27(11):1238-1244.

39. Perich D. *Low back pain in schoolgirl rowers: prevalence, bio-psycho-social factors and prevention*. Perth: School of Exercise, Biomedical and Health Sciences, Edith Cowan University; 2010.
40. Perich D, Burnett A, O'Sullivan F, Perkins C. Low back pain in adolescent female rowers: A multi-dimensional intervention study. *Knee Surgery, Sports Traumatology and Arthroscopy*. 2011;19(1):20-28.
41. Perich D, Burnett A, O'Sullivan P. Low back pain and the factors associated with it: Examination of adolescent female rowers. *24th International Conference on Biomechanics in Sports*; July 14-18, 2006; Salzburg, Austra.
42. Reid DA, Mcnair PJ. Factors contributing to low back pain in rowers. *British Journal of Sports Medicine*. 2000;34(5):321-322.
43. Richardson C, Jull G, Hodges P, Hides J. *Therapeutic Exercise for Spinal Segmental Stabilization in Low Back Pain: Scientific Basis and Clinical Approach*. Edinburgh: Churchill Livingstone; 1999.
44. Roland M, Fairbank J. The Roland-Morris disability questionnaire and the Oswestry disability questionnaire. *Spine*. 2000;25(24):3115-3124.
45. Roland M, Morris R. A study of the natural history of low back pain: Part 1. Development of a reliable and sensitive measure of disability in low-back pain. *Spine*. 1983;8(2):141-144.
46. Salminen JJ, Maki P, Oksanen A, Pentti J. Spinal mobility and trunk muscle strength in 15-year-old schoolchildren with and without low-back pain. *Spine*. 1992;17(4):405-411.
47. Smoljanovic T, Bojanic I, Hannafin JA, Hren D, Delimar D, Pecina M. Traumatic and overuse injuries among international elite junior rowers. *The American Journal of Sports Medicine*. 2009;37(6):1193-1199.
48. Strahan AD, Burnett AF, Caneiro JP, Doyle MM, O'Sullivan PB, Goodman C. Differences in spinopelvic kinematics in sweep and scull ergometer rowing. *Clinical Journal of Sport Medicine*. 2011;21(4):330-336.
49. Stratford P, Gill C, Westaway M, Binkley J. Assessing disability and change on individual patients: a report of a patient specific measure. *Physiotherapy Canada*. 1995;47(4):258-263.

50. Teitz CC, O'Kane J, Lind B, Hannafin JA. Back pain in intercollegiate rowers. *The American Journal of Sports Medicine*. 2002;30(5):674-679.
51. Thorpe A, O'Sullivan P, Burnett A, Caneiro J-P. Assessing the efficacy of a specific physiotherapy intervention for the prevention of low back pain in female adolescent rowers: A field study. *New Zealand Journal of Sports Medicine*. 2009;32(2):38-46.
52. van Dieen JH, Selen LP, Cholewicki J. Trunk muscle activation in low-back pain patients, an analysis of the literature. *Journal of Electromyography and Kinesiology*. 2003;13(4):333-351.
53. Van Hoof W, Volkaerts K, O'Sullivan K, Verschueren S, Dankaerts W. Cognitive functional therapy intervention including biofeedback for LBP during cycling. A single case study. *Sport and Geneeskunde*. 2011;44(4):20-26.
54. Van Hoof W, Volkaerts K, O'Sullivan K, Verschueren S, Dankaerts W. Comparing lower lumbar kinematics in cyclists with low back pain (flexion pattern) versus asymptomatic controls - field study using a wireless posture monitoring system. *Manual Therapy*. 2012;17(4):312-317.
55. Waddell G. Modern management of spinal disorders. *Journal of manipulative and physiological therapeutics*. 1995;18(9):590-596.
56. Wand BM, Parkitny L, O'Connell NE, Luomajoki H, McAuley JH, Thacker M, et al. Cortical changes in chronic low back pain: current state of the art and implications for clinical practice. *Manual Therapy*. 2011;16(1):15-20.
57. Wand BM, Tulloch VM, George PJ, Smith A, Goucke R, O'Connell, et al. Seeing it helps. Movement-related back pain is reduced by visualization of the back during movement. *Clinical Journal of Pain*. 2012;28(7):602-608.
58. Wilson F, Gormley J. Kinematics of lumbar spine motion in rowing during a fatiguing protocol: A comparison of ergometer and boat rowing. *British Journal of Sports Medicine*. 2011;45(4):383.

8.11 Supplementary material

Cognitive Functional Therapy for Single Case Rower

COGNITIVE COMPONENT

Education regarding the vicious cycle of pain specific to this rower:

The findings from his examination were outlined in a diagram in order to demonstrate all factors involved with development and persistence of his pain disorder. These included: negative beliefs about pain, a lack of awareness of his body schema; abdominal bracing associated with provocative movement patterns; avoidant behaviours; physical deconditioning; social isolation from sport and friends.

Clinical Findings

Negative Beliefs About Pain

'Bending is not good for me'
'Round thoracic is a bad posture'

Avoidance Behaviours

Told to avoid bending in sitting, squatting and rowing.

Passive Coping Strategies

Prolonged rest, NSAIDS, social isolation from rowing team

Core Stability

Performed core stability exercises and kept trunk upright in sitting and rowing

Cognitive Functional Therapy

Challenge beliefs

Review of the radiology, highlighted that no structural abnormalities were reported.

Education regarding movement behaviours. He had adopted protective movement patterns associated with co-contraction of the trunk muscles leading to increased loading and pain provocation. The importance of using the hips and legs during bending, lifting and squatting tasks to reduce focal stress was explained. The rower was able to experience that when performing his pain provoking activities in the new/relaxed way, there was an immediate reduction in pain. This was reinforced using feedback through use of video and mirrors.

Development of this rower's pain cycle:

Despite a normal radiological report the rower was told that he needed to protect his back from 'further damage'. The instructions were to avoid bending during sitting, lifting and rowing. However, no alternative strategies were proposed. In addition, he was advised to perform core stability exercises to enhance the stability of his spine and further protect it.

The rower reported that adopting a more rounded thoracic posture would alleviate his pain, however, he was advised that this was not a good posture and therefore he persisted with rowing in an upright posture.

The rower followed these instructions diligently despite an increase in pain levels, reduced rowing ability and an increase in disability.

Adopting a more relaxed rounded posture in fact relieved his symptoms.

Movement (bending, squatting and ergometer rowing) with a relaxed trunk (without abdominal bracing) reduced his pain.

Active Coping Strategies

Prescribed daily activities such as walking and stationary cycling. The physical activities were progressed to rowing-specific tasks (i.e. ergometer rowing and on-water rowing as described below).

Body awareness and specific movement training:

As a sweep rower, he needed to be able to reach forward and across (rotating his upper body towards the side he was rowing). Therefore, the ability to dissociate (move independently) between the thoracic region and the lumbo-pelvic region was considered important.

Lumbo-pelvic and thoraco-lumbar dissociation exercises were used to improve his body schema and awareness in space through the use of manual feedback in crook lying and sitting. This was soon progressed from manual feedback to the use of mirrors, so the athlete could actively correct himself.

The same process was repeated with the rower on the ergometer. Mirrors and digital photographs were used to compare his usual posture (thoracic upright sitting - flexed lumbar spine and extended thoracic spine) to a more relaxed posture (lumbo-pelvic upright sitting – extended lumbar spine and flexed thoracic spine).

Poor body schema



Poor lumbo-pelvic and thoraco-lumbar dissociation

(Co-contraction between abdominals and back extensors)



Rower's catch position

(Lack of anterior pelvic tilt and thoracic flexion with co-contraction of paraspinal and abdominal muscles)

Pelvic, lumbar, thoracic dissociation exercises

Lumbo-pelvic and thoraco lumbar dissociation exercises



Crook lying

(Focused on lumbo-sacral dissociation)



Ergometer

(Encouraged anterior pelvic tilt and thoracic flexion)

FUNCTIONAL COMPONENT

This component aimed to provide alternative strategies to normalise the rower's postural and movement behaviours allowing him to move in a pain-free manner

Using the aggravating factors on the Patient Specific Functional Scale, the physical therapist trained the rower to perform the previously pain provocative tasks in a relaxed and controlled manner, reducing his pain. For example, during bending, sit to stand, squatting; the rower had reduced pain when he maintained a more relaxed thorax and more bending through the knees and hips (see photos). These exercises aimed to initiate the drive to perform the task via the legs, as opposed to via the trunk.

Clinical Findings



Sitting
(co-contraction of paraspinal and abdominal muscles)



Bending
(Minimal hip flexion)

Cognitive Functional Therapy



Sitting
(Relaxed paraspinal and abdominal muscles, anterior pelvic tilt)



Bending
(Anterior pelvic tilt and relaxed paraspinal and abdominal muscles)



Sit to stand
(Thorax extended)



Sit to stand
(Relaxed thorax)



Squat
(Thorax extended)



Squat
(Relaxed thorax)

Posture retraining during ergometer rowing:

Based on the principles of normalisation of his movement in previous functional tasks, the rower was asked to adopt a more relaxed thoracic posture allowing him to reach further with his upper body. In addition, he was encouraged to engage his legs earlier during the drive phase. To facilitate the training of the new rowing technique, the rower was given exercises such as displayed.

In the clinic, the practice of the “new” posture during ergometer rowing was performed next to a long mirror, where the rower could check and correct his technique. The execution and visualisation of pain-free movement behavior re-enforces the adoption of a new/alternative movement strategy.

The “usual” and “new” rowing postures were filmed with the rower’s phone device so he could use these as a form of virtual training.



Catch Position
(Lack of hip flexion, anterior pelvic tilt and thoracic flexion)



Mid Drive
(Co-contracted paraspinal and abdominal muscles)



Catch Position
(Promote thoracic flexion at catch)



Mid Drive
(Relaxed paraspinal and abdominal muscles)

Exercise Dosage:

The rower was encouraged to perform these exercises to the point of loss of form (as perceived by the rower or as seen in the mirror) or muscle fatigue.

These exercises formed part of a circuit that was repeated 3 to 4 times in each session every second day. The set-up of this circuit also aimed to increase lower limb and back muscle endurance including sit and forward reach, sit to stand, squats, single leg squats and rowing drills (postural retraining).

On average, to accomplish a race, a rower has to perform 240 strokes, based on this information; the exercises were progressed, such that the rower's ultimate goal is to perform 240 repetitions of the exercises within the circuit session.

The rower was able to achieve that goal on week 6. The circuit was then performed 3 times a week for maintenance.



Finish Position
(Extended thorax & co-contracted paraspinal and abdominal muscles)



Finish Position
(Relaxed thorax & relaxed paraspinal and abdominal muscles)

Return to rowing program

- Week 1-2 Ergometer rowing – 2 to 5 minutes pain free in new posture
- Week 3-4 Ergometer rowing 15 minutes pain free -
- Week 5-6 On water rowing – single scull – 4km - daily
- Week 7 On water rowing - pair/four – 12 km – 3 x a week
- Week 8 On water rowing – eight sweep – return to crew rowing

Chapter 9 – Discussion and conclusion

9.1 Discussion and conclusion

This chapter provides a summary of the results as they relate to each of the studies' aims completed in this doctoral thesis. Discussion of how these results relate to the evidence that has been published then follows. Finally, it concludes with recommendations for future research.

Study One: Self-reported prevalence, pain intensity and risk factors for low back pain in adolescent rowers

Aim

- To quantify and compare the LBP prevalence (lifetime and point), pain intensity and rowing related risk factors of LBP in amateur adolescent male and female rowers.

Outcomes

- A high lifetime and point LBP prevalence were found in both adolescent male and female rowers.
- Adolescent male rowers had significantly higher lifetime and point LBP prevalence than adolescent female rowers.
- Moderate levels of pain were reported in both adolescent male and female rowers. Adolescent male rowers reported a lower level of pain intensity during rowing than adolescent female rowers.
- Similar rowing related aggravating factors were reported in both genders, with ergometer rowing, long rows in a training session and sweep rowing in an eight to be associated with LBP. Significantly fewer adolescent male rowers reported lifting a rowing shell to aggravate their LBP compared to adolescent female rowers.

Study Two: Caution: The Use of an Electromagnetic Device to Measure Spinal Motion on Rowing Ergometers

Aim

- To validate the use of an electromagnetic motion analysis system to measure spinal kinematics during ergometer rowing.

Outcomes

- The presence of metal on the ergometer significantly affected the validity of measurements using 3-Space Fastrak™ system (an electromagnetic motion analysis systems).
- This error was reduced to an average of 0.4° when using a modified ergometer.

Study Three: Gender differences in trunk and pelvic kinematics during prolonged ergometer rowing in adolescents

Aim

- To compare the regional lumbar, pelvic and thoracic spine kinematics between healthy adolescent male and female rowers during ergometer rowing.

Outcomes

In comparison to adolescent females, adolescent males typically:

- Had a significantly shorter drive phase.
- Rowed with their pelvis in more posterior tilt and their lower thoracic region more flexed.

Study Four: Spinal kinematics of adolescent male rowers with back pain in comparison to matched controls during ergometer rowing

Aim

- To compare the regional lumbar kinematics of adolescent male rowers with and without LBP.

Outcomes

- Adolescent male rowers demonstrated a summation of pain across 15 minutes of ergometer rowing.
- Adolescent male rowers with LBP had greater variability in the upper and lower lumbar angles during the drive phase than adolescent male rowers with no-LBP during a 15-minute ergometer trial.
- Adolescent male rowers with LBP positioned their upper lumbar spine nearer to end of range flexion for a greater proportion of their drive phase than adolescent male rowers with no-LBP.

Study Five: Cognitive functional therapy to manage low back pain rowers: a randomised controlled trial

Aim

- To investigate the efficacy of cognitive functional therapy (CFT) in reducing pain and disability and whether it can alter trunk and lower limb muscle endurance, spinal posture and regional lumbar kinematics in adolescent male rowers with LBP using a randomised controlled trial.

Outcomes

- Use of CFT was more effective to reduce pain and disability in adolescent male rowers with LBP in a randomised controlled trial than no treatment.

- The improvement in pain and disability was associated with a more extended lower lumbar angle in usual sitting and a significant improvement in lower limb muscle endurance.
- Although improvement in back muscle endurance did not reach statistical significance, clinically meaningful differences were observed.
- Differences in regional lumbar kinematics were not observed.

Study Six: Cognitive functional therapy for the management of low back pain in an adolescent male rower: a case report

Aim

- To investigate the efficacy of cognitive functional therapy in reducing LBP and disability in an adolescent male rower with high pain and disability.

Outcomes

- Cognitive functional therapy was effective in reducing pain, disability and changing hip and spino-pelvic kinematics during ergometer rowing in the management of one adolescent male rower.

A number of studies have investigated the prevalence of LBP and the impact of spinal kinematics on rowing.^{7,9,17,19,22 1-4,6,8,12,18,21,23,25,26} However, no study to date has investigated the LBP prevalence or risk factors and the effect of a targeted intervention in the specific subpopulation of adolescent male rowers. As age and gender are known to be LBP risk factors, considering the implications for this demographic is pertinent to further developments in prevention and treatment. Of the 157 adolescent male rowers who completed a LBP questionnaire (appendix G), 93.8% reported that they had experienced an episode of LBP in their life and 64.6% reported they were experiencing pain during rowing at the time of testing. These rates appear to be higher than the general adolescent population (39.9% lifetime and 12.0% point prevalence)⁵ and also female adolescent rowers (47.5% point

prevalence).¹⁷ This highlights that research regarding LBP mechanisms and efficacy of LBP interventions are particularly necessary in this population.

The differences in LBP prevalence between males and females were suggestive of differing mechanisms provoking LBP between genders in the adolescent age group. This suggestion was in part confirmed, given that adolescent male and females demonstrated different pelvic and thoracic kinematics during ergometer rowing, although it must be acknowledged that self-reported rowing related aggravating factors were similar between genders. The male cohort typically rowed with more posterior pelvic tilt and greater thoracic flexion than the females, supporting further investigation as to whether these represent risk factors for LBP. Therefore, further research comparing adolescent male rowers with and without LBP was undertaken and the results confirmed that kinematics during ergometer rowing might be a risk factor for LBP.^{3,4,8,11,15,18,26} The rowers with LBP typically positioned their upper lumbar spine in flexion for a greater duration of their drive phase compared to age matched pain free controls. These findings may have implications for increased flexion loading and end range strain in the lumbar spine, which has previously been suggested to relate to LBP in adult and adolescent rowers.^{4,8,18,26} Adolescent male rowers with LBP also demonstrated greater variability in their regional lumbar kinematics during ergometer rowing. It is not known whether these findings represent a response to pain during rowing or reflects underlying motor control deficit related to this activity that may in itself be provocative.

Finally, a LBP management approach called cognitive functional therapy (CFT) has been adapted for the treatment of LBP in rowers.^{16,24} Two non-randomized trials have previously demonstrated success in cohorts of female adolescent rowers with reductions in pain and associated disability following the intervention.^{16,24} However, given that there are clear differences in muscle endurance, body postures and movement patterns between genders,^{10,13,14,20} the CFT approach to treating adolescent male rowers with LBP must be adapted with these differences in mind. The RCT confirmed that this treatment approach is also effective in the management of

adolescent male rowers. This study found that the 19 (out of 36) adolescent male rowers that were randomly allocated to the CFT intervention group had reduced pain intensity during ergometer rowing and disability than rowers who were allocated to the control group. Associated improvements in muscle endurance of the lower limbs were detected and rowers sat with more upright posture. Although statistical significance was not achieved for improvements in BME, clinically meaningful differences were also observed. No changes in regional lumbar kinematics were evident in either group following the intervention. The success of such intervention without a group change in regional lumbar kinematics could be due to desensitisation of the previously painful lumbar spinal structures due the improvements in lower limb and back muscle conditioning and changes in the usual sitting posture coupled with the cognitive aspects of the intervention that targeted pain coping strategies and feedback. It is possible that there were individual differences that occurred which were washed out in the group analysis. This hypothesis was in part supported by the final study of the thesis, where an improvement in pain and disability was associated with differences in the hip and spino-pelvic kinematics during ergometer rowing in an adolescent male rower.

9.2 Future studies

The results of these studies while definitive in their clinical implications also highlight areas for further studies. The link between lumbar spine joint forces and moments during ergometer rowing and LBP requires clarification. A cross-sectional study of lumbar kinetics between adolescent rowers with and without pain may provide further insight into the risk factors for LBP in this subpopulation, as joint forces and moments were not measured in this study. Given that the direct mechanism for kinematic change following CFT cannot be confirmed, future studies should include electromyography (EMG) data to detect changes in muscle activity during ergometer rowing following intervention to investigate whether this correlates with a reduction of LBP in rowers. The cognitive functional approach, which was shown to be effective in adolescent rowers, should be trialed with elite nationally competitive rowers or wider demographics in order to confirm its broader relevance.

Finally, future trials investigating the efficacy of CFT on a large group of rowers should be compared to an alternative intervention such as non-targeted strength and conditioning in order to reduce treatment group bias.

9.3 References

1. Bahr R, Andersen SO, Loken S, Fossan B, Hansen T, Holme I. Low back pain among endurance athletes with and without specific back loading--a cross-sectional survey of cross-country skiers, rowers, orienteers, and nonathletic controls. *Spine*. 2004;29(4):449-454.
2. Budgett RG, Fuller GN. Illness and injury in international oarsmen. *Clinical Sports Medicine*. 1989;7:49-52.
3. Bull AMJ, McGregor AH. Measuring spinal motion in rowers: the use of an electromagnetic device. *Clinical Biomechanics*. 2000;15(10):772-776.
4. Caldwell JS, McNair PJ, Williams M. The effects of repetitive motion on lumbar flexion and erector spinae muscle activity in rowers. *Clinical Biomechanics*. 2003;18(8):704-711.
5. Calvo-Munoz I, Gomez-Conesa A, Sanchez-Meca J. Prevalence of low back pain in children and adolescents: a meta-analysis. *BMC Pediatrics*. 2013;13:14.
6. Foss IS, Holme I, Bahr R. The prevalence of low back pain among former elite cross-country skiers, rowers, orienteers, and nonathletes: a 10-year cohort study. *The American Journal of Sports Medicine*. 2012;40(11):2610-2616.
7. Hickey GJ, Fricker PA, McDonald WA. Injuries to elite rowers over a 10-yr period. *Medicine & Science in Sports & Exercise*. 1997;29(12):1567-1572.
8. Holt PJ, Bull AMJ, Cashman PM, McGregor AH. Kinematics of spinal motion during prolonged rowing. *International Journal of Sports Medicine*. 2003;24(8):597-602.
9. Howell D. Musculoskeletal profile and incidence of musculoskeletal injuries in lightweight women rowers. *The American Journal of Sports Medicine*. 1984;12(4):278-281.
10. Mannion AF, Dumas GA, Cooper RG, Espinosa FJ, Faris MW. Muscle fibre size and type distribution in thoracic and lumbar regions of erector spinae in healthy subjects without low back pain: normal values and sex differences. *Journal of Anatomy*. 1997;190(4):505-513.

11. McGregor AH, Bull AM, Byng-Maddick R. A comparison of rowing technique at different stroke rates: a description of sequencing, force production and kinematics. *International Journal of Sports Medicine*. 2004;26(6):465-470.
12. McGregor AH, Patankar ZS, Bull AMJ. Spinal kinematics in elite oarswomen during a routine physiological "step test". *Medicine & Science in Sports & Exercise*. 2005;37(6):1014-1020.
13. McGregor AH, Patankar ZS, Bull AMJ. Do men and women row differently? A spinal kinematic and force perspective. *Proceedings of the Institution of Mechanical Engineers. Part P, Journal of Sports Engineering and Technology*. 2008;222(2):77-83.
14. Miller AEJ, MacDougall JD, Tarnopolsky MA, Sale DG. Gender differences in strength and muscle fiber characteristics. *European Journal of Applied Physiology and Occupational Physiology*. 1993;66(3):254-262.
15. O'Sullivan F, O'Sullivan J, Bull AMJ, McGregor AH. Modelling multivariate biomechanical measurements of the spine during a rowing exercise. *Clinical Biomechanics*. 2003;18(6):488-493.
16. Perich D, Burnett A, O'Sullivan F, Perkins C. Low back pain in adolescent female rowers: A multi-dimensional intervention study. *Knee Surgery, Sports Traumatology and Arthroscopy*. 2011;19(1):20-28.
17. Perich D, Burnett A, O'Sullivan P. Low back pain and the factors associated with it: Examination of adolescent female rowers. *24th Symposium of the International Society of Biomechanics in Sports*. Salzburg, Austria: 2006.
18. Pollock CL, Jones IC, Jenkyn TR, Ivanova TD, Garland SJ. Changes in kinematics and trunk electromyography during a 2000 m race simulation in elite female rowers. *Scandinavian Journal of Medicine & Science in Sports*. 2012;22(4):478-487.
19. Smoljanovic T, Bojanic I, Hannafin JA, Hren D, Delimar D, Pecina M. Traumatic and overuse injuries among international elite junior rowers. *The American Journal of Sports Medicine*. 2009;37(6):1193-1199.

20. Straker LM, O'Sullivan PB, Smith A, Perry M. Computer use and habitual spinal posture in Australian adolescents. *Public Health Reports*. 2007;122(5):634-643.
21. Stutchfield BM, Coleman S. The relationship between hamstring flexibility, lumbar flexion, and low back pain in rowers. *European Journal of Sport Science*. 2006;6(4):255-260.
22. Teitz CC, O'Kane J, Lind B, Hannafin JA. Back pain in intercollegiate rowers. *The American Journal of Sports Medicine*. 2002;30(5):674-679.
23. Teitz CC, O'Kane JOK, Lind BK. Back Pain in Former Intercollegiate Rowers A Long-term Follow-up Study. *The American Journal of Sports Medicine*. 2003;31(4):590-595.
24. Thorpe A, O'Sullivan P, Burnett A, Caneiro J-P. Assessing the efficacy of a specific physiotherapy intervention for the prevention of low back pain in female adolescent rowers: A field study. *New Zealand Journal of Sports Medicine*. 2009;32(2):38-46.
25. Wilson F, Gissane C, Gormley J, Simms C. A 12-month prospective cohort study of injury in international rowers. *British Journal of Sports Medicine*. 2010;44(3):207-214.
26. Wilson F, Gissane C, Gormley J, Simms C. Sagittal plane motion of the lumbar spine during ergometer and single scull rowing. *Sports Biomechanics*. 2013;12(2):132-142.

Appendix A – Research Grant



Private & Confidential

21 July 2009

Mr Leo Ng
Curtin University of Technology
GPO Box U1987
Perth WA 6845

Dear Leo

Re: PRF Application No: T09-THE/SPA001
Title: "Efficacy of a specific physiotherapy exercise intervention to alter spinal kinematics and reduce low back pain in adolescent male rowers."

Thank you for applying for a 2009 PRF tagged research grant.

The PRF Grants Review Committee has now considered all applications with due care. I am pleased to inform you that you have been awarded a PRF tagged Sports Physiotherapy Australia research grant to the value of \$8,400.

For your information, please find enclosed a summary evaluation of your application.

I will be sending you a PRF contract in the near future. This needs to be signed before any grant monies will be paid.

Congratulations on being awarded a PRF tagged grant for 2009 and all the best for your future research career.

Yours sincerely

A handwritten signature in black ink, appearing to read "Vicki Downs".

Vicki Downs
Administrative Officer (Quality Practice)

Appendix B – Conference Proceeding

GENDER DIFFERENCES IN MOTOR CONTROL OF THE TRUNK DURING PROLONGED ERGOMETER ROWING

Leo Ng¹, Angus Burnett^{1,2} and Peter O'Sullivan¹

¹ School of Physiotherapy, Curtin University of Technology, Western Australia

² School of Exercise, Biomedical and Health Sciences, Edith Cowan University, Western Australia

The aim of the study was to compare the temporal kinematics of a stroke, spino-pelvic kinematics, trunk and quadriceps muscle activation in prolonged ergometer rowing between males and female rowers. Twelve adolescent rowers performed a 20 minute rowing ergometer trial at a high self perceived rate of exertion. Spino-pelvic kinematics, muscle activity and temporal kinematics data were compared in the 1st, 10th and 20th minute. The results from this study indicate there is a difference in temporal kinematics of a rowing stroke between adolescent males and females. Furthermore, males row with a more flexed thoracic spine and a posteriorly rotated sacrum compared to females at the catch and the finish positions.

Key Words: adolescent, rowing, gender differences, motor control, posture

INTRODUCTION:

Rowing is perceived to have a lower risk of injury when compared to contact sports while still providing physical and mental health benefits. However, a recent study by Perich et al. (2006) found the point prevalence of low back pain (LBP) in a large group of adolescent female rowers was 47.5%. This was approximately three times the prevalence of a matched control group.

In a study examining elite rowers, 25.0% of all injuries reported by male rowers were of the lumbar spine when compared to 15.2% for females (Hickey et al., 1997). Hosea et al. (1989) speculated that such a difference in the incidence of LBP between males and female rowers may be due to increased forces on the lumbar spine in male rowers. Further, differences in usual sitting posture between males and females have also been reported. Specifically, males displayed a more flexed lumbar spine and a more posteriorly tilted pelvis compared to females in sitting (Dunk and Callaghan, 2005). As rowing is a seated sport and sitting is known to be a major exacerbating factor in LBP, this raises the question whether differences exist in spino-pelvic posture in adolescent male and female athletes whilst rowing.

To date, no study has examined whether between-gender differences exist in spino-pelvic kinematics and trunk muscle activation in rowers. Therefore, the aim of this study was to compare spino-pelvic kinematics and trunk and quadriceps muscle activation in adolescent male and female rowers whilst performing a prolonged rowing trial on a rowing ergometer.

METHODS:

Data Collection: In this study, 12 rowers between the ages of 14-17 years with no history of LBP were recruited. Six males and six females mean (SD) age; 16.5 (0.8) and 15.1 (0.8) years, height; 1.82 (0.08) m and 1.71 (0.05) m and mass; 72.7 (11.3) and 66.2 (12.2) kg respectively participated in this study. All rowers were performing rowing training at least three times a week and competing in rowing regattas at the time of testing.

Subjects were asked to perform a warm-up that included ergometer rowing and stretching. During actual testing, subjects were requested to row for a maximum of 20 minutes at a stroke rate of 22 strokes per minute (spm) at an exertion of greater than 17 on the Borg scale. Synchronised spino-pelvic kinematics and trunk and quadriceps muscle activation were collected whilst rowing for a period of 15 seconds every minute.

Prior to undertaking the testing protocol, a validation study was conducted to determine whether collecting kinematic data using a 3-Space Fastrak™ (Polhemus Navigation Science Division, Kaiser Aerospace, Vermont) was feasible. The Fastrak™ is an electromagnetic tracking device and this may be problematic as a standard rowing ergometer contains a large amount of ferrous material. A Concept II rowing ergometer was modified so that its beam and footings were precisely replaced with non-ferrous components (wood).

Four electromagnetic sensors were placed on a wooden model that replicated a typical static lumbar posture. For both the standard and modified ergometers, this model was secured to the ergometer's seat and moved forward and backwards five times simulating five rowing cycles. Three cycles were completed and elevation angles (angles about the Y-axis-flexion/extension) were recorded from the Fastrak™ and compared to angles previously measured from the spine model using an inclinometer. Data were analysed so that two measures of accuracy and variability were obtained. Accuracy was determined by comparing values measured by the Fastrak™ to angles directly measured by the inclinometer whilst variability was assessed by measuring the standard deviation of the data throughout the simulated rowing strokes (i.e. three trials and five strokes/ trial). Mean flexion/extension angles (from four sensors) recorded by the Fastrak™ were -5.4° for the standard ergometer and 1.4° for the modified ergometer. This was compared to a value of 1° from the inclinometer. With respect to variability, the average of the standard deviation values obtained was less for the modified ergometer (0.8°) when compared to the standard ergometer (3.4°). On the basis of the pilot study, spino-pelvic kinematic data was collected using the modified ergometer.

During the rowing trials, four sensors were affixed to the skin overlying the spinous processes of T6, T12, L3 and S2. Prior to these trials, subjects' spinal range of motion in sitting was obtained by subject's slumping their spine towards maximum flexion. The subjects were then positioned into a neutral spinal posture. Three trials for flexion ROM and neutral spine position were captured and a mean value was then obtained. The following spino-pelvic angles were defined: *Pelvis* – S2 relative to the magnetic source; *Lower Lumbar* – L3 relative to S2; *Upper Lumbar* – T12 relative to L3; *Lower Thoracic* – T6 relative to T12.

Muscle activation was recorded bilaterally from three muscles (vastus lateralis (VL), superficial lumbar multifidus (SLM) and the erector spinae at the level of T9 (EST9)) at 1000Hz (bandwidth 10-500 Hz and the common mode rejection ratio >115 db at 60 Hz). These data were collected using an Octopus Cable Telemetric system (Bortec Electronics Inc., Calgary, Canada). Two silver/silver chloride disposable surface electrodes (inter-electrode distance - 20mm) were placed on the skin after the skin was abraded and cleaned with ethanol so that the resistance was less than 5Ω . A ground electrode was placed over the left anterior superior iliac crest. EMG data were full wave rectified and low pass filtered at 4 Hz to generate a linear

envelope. Data was then amplitude normalised using sub-maximal voluntary isometric contractions (sub-MVIC). To generate the sub-MVIC for SLM and EST9, subjects were asked to lie prone with knees flexed 90 degrees and lift their knees off the plinth for 3 seconds (Dankaerts et al., 2004). For VL, the MVIC values were taken as the maximum value recorded over an average of 100ms in the first minute of the rowing trial.

Data Analysis: EMG and spino-pelvic kinematic data were simultaneously collected and synchronised using the length of chain on the ergometer. Chain length (and thus drive and recovery phases) was derived via a rotary encoder attached to the flywheel. On the basis of this data, drive phase duration, stroke rate and stroke length were calculated. Muscle activation data calculated using Root Mean Square (RMS) with a window length of 50ms. All data were time normalized (0-100%) using an interpolative spline and ensemble averages were obtained from five completed rowing cycles within the 15-second window. All kinematic and EMG muscle activation variables at the catch and finish positions were screened for normality (Shapiro-Wilks test) and data were deemed to be normally distributed. Hence, a two-way ANOVA with one between-subjects variable (gender) and one within-subjects variable (time) was conducted. Paired t-tests were used to determine whether muscle activation differed between the left and right paired muscles. All statistical procedures were conducted using SPSS V13.0 and the level of significance was set at $p < 0.05$.

RESULTS AND DISCUSSION:

With respect to temporal and kinematic features of the stroke, males spent 35.5(1.1)%, 37.3(1.6)% and 38.2(3.1)% in the drive phase during the first minute, the tenth minute and the twentieth minute respectively. This was significantly less ($p = 0.005$) than recorded for females (42.5(3.1)%, 41.2(3.3)% and 42.6(3.7)%). No significant differences were found in stroke rate (males = 22.9 (1.3) spm, females = 22.7 (2.2) spm) or stroke length (males = 1.53 (0.10) m and females (1.48 (0.10) m). For spino-pelvic kinematic data, significant differences were found in the sacral angle at the finish ($p = 0.002$) (Figure 1) and also the thoracic angle at the catch ($p = 0.002$) and finish ($p = 0.02$) (Figure 2). Differences were seen in the sacral angle at catch, but statistical significance was not achieved ($p = 0.08$). No differences were observed in the lower lumbar or upper lumbar spinal angles. A greater posterior pelvic tilt angle and a greater flexion angle in the thoracic spine reported in this study indicates a more slouched thoracic rowing posture in males when compared to females and this supports previous findings in normal sitting (Dunk and Callaghan, 2005). Posterior pelvic tilt reflects a change in hip and/or lumbar spine angles. Given that the lumbar spine angles were not different between gender, these findings are likely to reflect a difference in the functional hip range during rowing i.e. less hip flexion in males, although this was not formally measured.

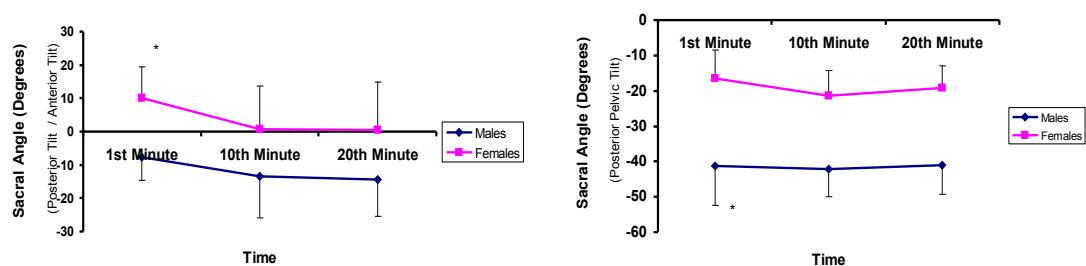

Figure 1. Sacral angle at the catch (left) and finish (right).

(* Denotes differences in angle between gender of $P < 0.05$ at specified time)

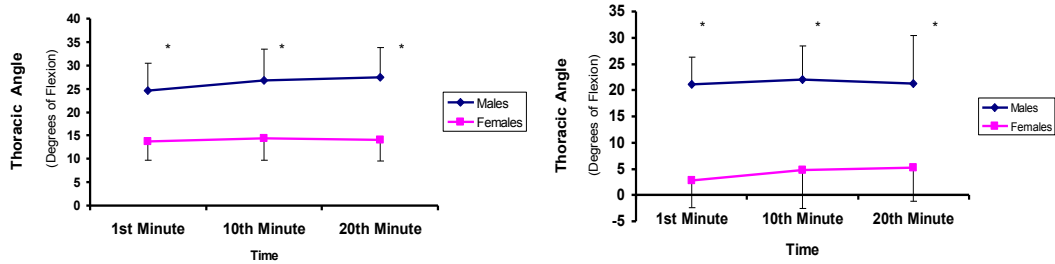

Figure 2. Thoracic angle at the catch (left) and finish (right).
 (* Denotes differences in angle between gender of $P < 0.05$ at the allocated time)

For EMG data, no significant differences in muscle activation were found between the left and right sides so data were averaged to represent activation of one muscle group. Further, no differences in muscle activation existed between gender over time (Figures 3 and 4).

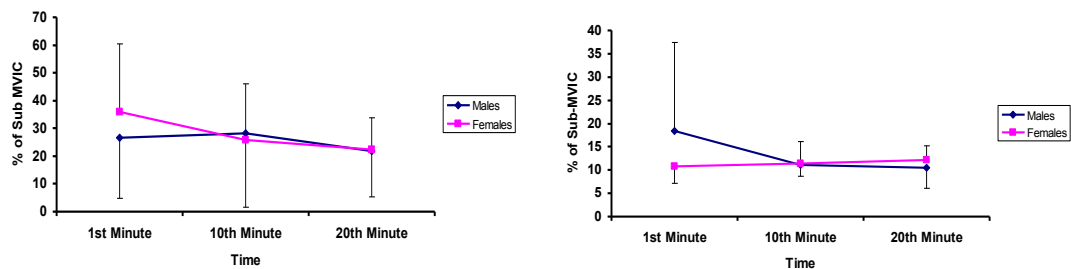

Figure 3. Muscle activation of the EST9 at the catch (left) and finish (right).

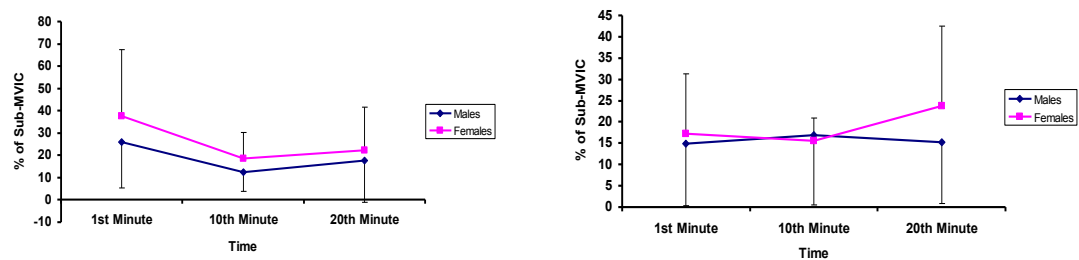

Figure 4. Muscle activation of the SLM at the catch (left) and finish (right).

CONCLUSIONS:

From the results of this study there is evidence to suggest that spino-pelvic kinematics differ between gender. Specifically, males tend to row with a more 'slouched' thoracic posture in addition to a greater posterior tilt. No differences were found in EMG data to support differences in muscle activation of superficial spinal muscles or the quadriceps, although insufficient statistical power may have limited these findings. Further study with a greater sample size is required.

REFERENCES:

- Dankaerts, W., O'Sullivan, P. B., Burnett, A. F., Straker, L. M. & Danneels, L. A. (2004). Reliability of EMG measurements for trunk muscles during maximal and sub-maximal voluntary isometric contractions in healthy controls and CLBP patients. *Journal of Electromyography and Kinesiology*, **14**, 333-342.
- Dunk, N.M., & Callaghan, J.P. (2005). Gender-based differences in postural responses to seated exposures. *Clinical Biomechanics*, **20**, 1101-1110.
- Hickey, G.J., Fricker, P.A., & McDonald, W.A. (1997). Injuries to elite rowers over a 10-yr period. *Medicine and Science in Sports and Exercise*, **29**, 1567-1572.

Hosea, T., Bolard, A., McCarthy K & Kennedy, T. (1989). Rowing injuries. *Post graduate Advances in Sports Medicine*. University of Pennsylvania: Forum Medicum Inc, **3**, 1-16.

Perich, D., Burnett, A. & O'Sullivan, P. (2006). Low back pain and the factors associated with it: Examination of adolescent female rowers. XXIVth Symposium of the International Society of Biomechanics in Sports, (Edited by H. Schwameder, G. Strutzenberger, V. Fastenbauer, S. Lidinger, E. Muller). pp. 355-358, The University of Salzburg.

Teitz, C.C., O'Kane, J.O.K., Lind, B.K. & Hannafin, J.A. (2002). Back pain in intercollegiate rowers. *The American Journal of Sports Medicine*, 30, 674-679.

SPINO-PELVIC KINEMATICS AND TRUNK MUSCLE ACTIVATION IN PROLONGED ERGOMETER ROWING: MECHANICAL ETIOLOGY OF NON-SPECIFIC LOW BACK PAIN IN ADOLESCENT ROWERS

Leo Ng¹, Angus Burnett^{1,2} and Peter O'Sullivan¹

¹ School of Physiotherapy, Curtin University of Technology, Western Australia

² School of Exercise, Biomedical and Health Sciences, Edith Cowan University, Western Australia

The aim of this study was to determine whether adolescent rowers with and without low back pain (LBP) displayed differences in spino-pelvic kinematics and trunk muscle activation during prolonged ergometer rowing. Ten rowers with LBP and twelve rowers without LBP performed a 20 minute ergometer trial with kinematics, muscle activation and self reported perception of pain data (VAS) collected during the trial. Results of this study show that rowers with LBP postured their lumbar spine in flexion for a greater proportion of the drive phase and nearer to their end range of flexion when compared to those without LBP. This study highlights potential mechanisms for the ramping of back pain in adolescent rowers.

Key Words: adolescent, rowing, low back pain, posture, motor control

INTRODUCTION:

A recent study by Perich et al. (2006) reported that the point prevalence of low back pain (LBP) in a large group of adolescent female rowers was 47.5% when compared to the incidence of LBP in an age matched control group (15.5%). It was also reported in the study of Perich and associates that mechanical factors appeared to be dominant in the development of LBP. These mechanical factors that may contribute to increasing the sensitisation of spinal structures include; reduced lower limb and back muscle endurance which may in turn result in increased forces being transferred to the passive spinal structures (Perich et al., 2006).

A classification method of chronic LBP has been proposed, whereby patients' pain is associated with deficits in segmental spinal control resulting in peripheral generation of back pain (¹⁶). Five sub-groups of non-specific chronic LBP patients have been reliably identified by musculoskeletal physiotherapists (Dankaerts et al., 2006). Of these groups, it is the 'flexion' pattern disorder that is most common in adolescent female rowers (Perich, Unpublished data). This pattern is defined as flexion pain provocation associated with a loss of control of the lumbar spine into flexion placing flexion-related strain on spinal structures.

Although it is clear that rowing is commonly associated with LBP, there has been little examination of the LBP ramping mechanisms in rowers. Therefore, the aim of the study was to determine whether differences in spino-pelvic kinematics data and surface electromyography (EMG) exist in rowers with LBP (with flexion pattern classification) and those without LBP during a prolonged rowing trial.

METHODS:

Data Collection: In this study, 22 rowers (10 males, 12 females) between the ages of 14-17 years, with and without LBP, completed testing (Table 1). Subjects with LBP rated their usual levels of pain and their rowing related pain levels using a visual analog scale (VAS). A battery of clinical tests in conjunction with subjective pain evaluation (O'Sullivan, 2000) was used to positively identify subjects with a 'flexion' pattern classification of LBP. The inclusion criteria for this study were; a typical increase in the level of back pain to above 3/10 within 30 minutes of rowing training, performing training at least 3 times a week and competing in rowing regattas.

Table 1: Characteristics of the no-LBP and LBP groups.

	No-LBP (N = 12-6 Males, 6 Females)	LBP (N = 10-4 Males, 6 Females)
Age (years)	15.8 (0.7)	16.0 (1.0)
Height (m)	1.77 (0.09)	1.73 (0.08)
Mass (kg)	69.5 (11.7)	67.9 (8.8)
Pain - Usual (/10)	0	5.3 (2.3)
Pain – Rowing (/10)	0	4.7 (2.8)

In the period before testing, other forms of exercise were not restricted. Prior to undergoing the experimental protocol subjects were asked to perform a warm-up that included ergometer rowing and stretching. Subjects were then requested to row on a modified rowing ergometer (ferrous supports replaced with wood) for a maximum of 20 minutes at a rate of 22 strokes per minute (spm). Subjects in both groups were asked to row at an exertion of greater than 17 on the Borg scale (range of 6 to 20) and ratings of exertion and VAS scores were collected every minute. Testing ceased if the level of back pain experienced by the subjects exceeded that experienced during normal rowing sessions (as determined by individual VAS scores).

Whilst rowing on the ergometer, synchronised trunk and quadriceps muscle activation and spino-pelvic kinematics were collected for a period of 15 seconds every minute. Spino-pelvic kinematic data were collected using the 3-Space Fastrak™ (Polhemus Navigation Science Division, Kaiser Aerospace, Vermont) which measures angle to 0.2°. During rowing trials, four sensors were affixed to the skin overlying the spinous processes of T6, T12, L3 and S2. Prior to testing, subjects' spinal ranges of motion in sitting were also obtained by subject's slumping their spine to maximum flexion. Subjects were then positioned into a neutral spinal posture by an experienced musculoskeletal physiotherapist. Three trials for flexion range of movement and neutral spine position were captured and a mean value was obtained. The following spino-pelvic angles were defined: *Pelvis* – S2 relative to the magnetic source; *Lower Lumbar* – L3 relative to S2; *Upper Lumbar* – T12 relative to L3; *Lower Thoracic* – T6 relative to T12.

Muscle activation was recorded bilaterally from three muscles at 1000Hz (bandwidth 10-500 Hz and the common mode rejection ratio >115 db at 60 Hz) using an Octopus Cable Telemetric system (Bortec Electronics Inc., Calgary, Canada). Data were recorded from the vastus lateralis (VL), superficial lumbar multifidus (SLM) and the erector spinae at the level of T9 (EST9). Two silver/silver chloride disposable surface electrodes (inter-electrode distance - 20mm) were placed on the skin after the skin was abraded and cleaned with ethanol so that the resistance was less than 5Ω. A ground electrode was placed over the left anterior superior iliac crest. Raw EMG data were demeaned and then amplitude normalised using sub-maximal voluntary isometric contractions (sub-MVIC). To determine the sub-MVIC for SLM

and EST9, subjects were asked to lie prone with knees flexed 90 degrees and lift their knees off the plinth for 3 seconds⁽⁴⁴⁾. For VL, the MVIC values were taken as the maximum value recorded over an average of 100ms in the first minute of the rowing trial.

Data Analysis: EMG and spino-pelvic kinematic data were simultaneously collected and synchronised using the length of chain on the ergometer. Drive and recovery phases were identified using a rotary encoder. On the basis of these data, drive phase duration, stroke rate and stroke length were calculated. Muscle activation data were calculated using Root Mean Square (RMS) with a window length of 50ms. All data were time normalized (0-100%) using an interpolative spline and ensemble averages were obtained from five completed rowing cycles within the 15-second window. All kinematics (spinal-pelvic angles) and EMG muscle activation variables at catch and at the finish position were screened for normality (Shapiro-Wilks test) and data were deemed to be normally distributed. Therefore, a two-way ANOVA with one-between subjects variable (LBP status) and one repeated measures variable (time) was conducted. All statistical procedures were conducted using SPSS V13.0 and the level of significance was set at $p < 0.05$.

RESULTS AND DISCUSSION:

There was a gradual increase in level of LBP experienced by the LBP group during the 20 minute rowing ergometer trial (Figure 1). Two rowers (1 male and 1 female) ceased testing after 15 minutes of the rowing trial as the level of pain exceeded that of normal training. One subject in the LBP group did not report pain during the rowing trial, but complained of pain the following day. This subject was included in the pain group as this is a common clinical finding in rowers after training.

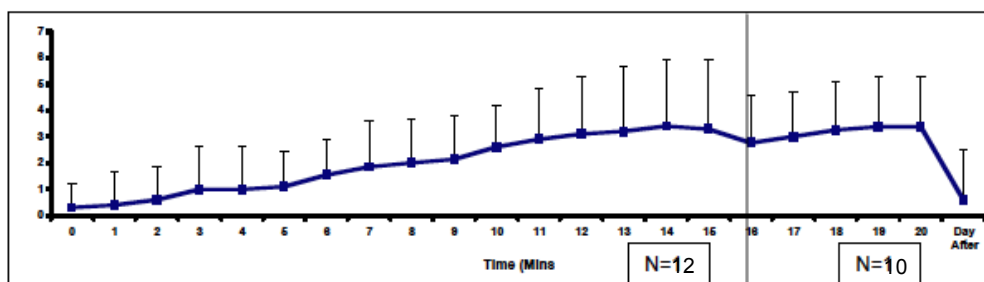

Figure 1: Average of reported levels of LBP (VAS - /10) during the rowing ergometer trial.

In this study, rowers with LBP spent a significantly longer time in flexion as compared to those without LBP during the drive phase ($p=0.025$) although there was no difference within groups across time. Furthermore, rowers with LBP also spent a greater proportion of time during the drive phase near end range of lumbar spine flexion (above 90% of full flexion) ($p=0.026$) (Figure 2). These were consistent across time and there were no interaction between time and group. Similar findings were evident in the recovery phase, but the difference did not reach statistical significance ($p=0.082$ and $p=0.106$ respectively). No other significant differences or trends were noted in other spinal angles.

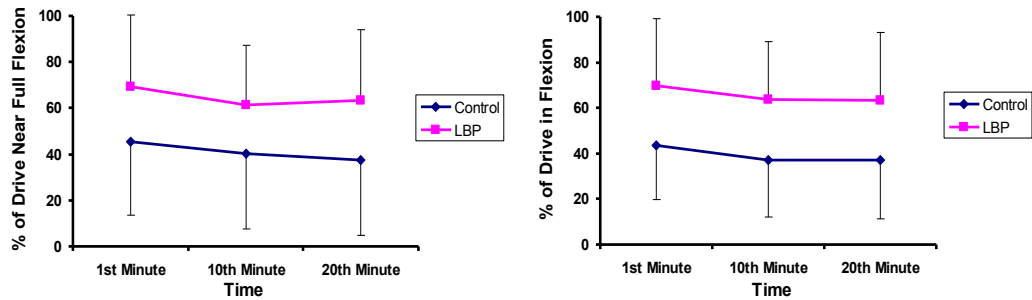

Figure 2: Percentage of drive phase with the lower lumbar spine spent in flexion (left) and spent in greater than 90% of full flexion (right).

With regards to muscle activation data, no significant differences were found for muscle activation between left and right sides. Therefore, these data were averaged to represent muscle activation of one muscle group. No differences were found at the start of the trial, however, although rowers with LBP had a trend towards greater activation in EST9 at the 20th minute when compared to rowers without LBP at catch (Figure 3). No differences or trends between pain and control subjects were found in the SLM (Figure 4) and VL at catch or finish.

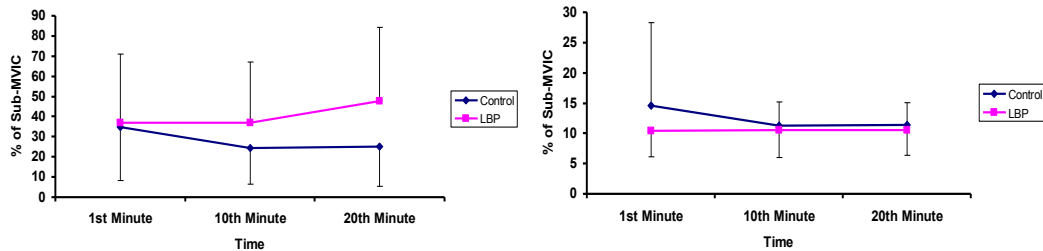

Figure 3. Muscle activation of the EST9 at the catch (left) and finish (right).

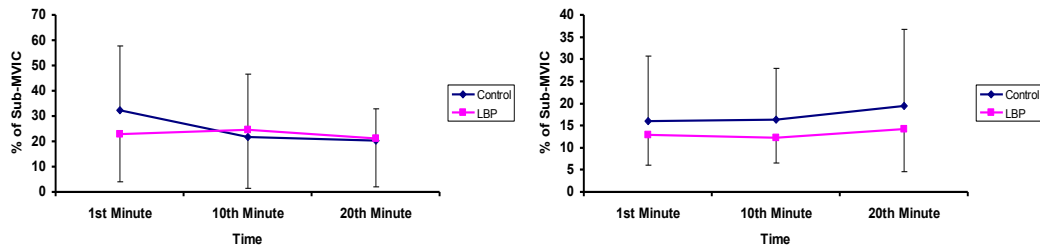

Figure 4. Muscle activation of the SLM at the catch (left) and the finish (right).

CONCLUSIONS:

This study suggests that rowers with LBP spent a greater proportion of their rowing stroke in flexion when compared to rowers without LBP during the drive phase. Furthermore, rowers with LBP spent a greater amount of time near full flexion in the lower lumbar spine when compared to rowers without LBP during a prolonged rowing trial on an ergometer. These findings indicate that rowers with LBP are exposed to greater flexion strain and potential passive structure loading which may represent a mechanism for their disorder.

REFERENCES:

- Dankaerts, W., O'Sullivan, P. B., Burnett, A. F., Straker, L. M. & Danneels, L. A. (2004). Reliability of EMG measurements for trunk muscles during maximal and sub-maximal voluntary isometric contractions in healthy controls and CLBP patients. *Journal of Electromyography and Kinesiology*, **14**, 333-342.
- Dankaerts, W., O'Sullivan, P. B., Straker, L. M., Burnett, A. F., & Skouen, J. S. (2006). The inter-examiner reliability of a classification method for non-specific chronic low back pain patients with motor control impairment. *Manual Therapy*, **11**, 28-39.
- Perich, D., Burnett, A. & O'Sullivan, P. (2006). Low back pain and the factors associated with it: Examination of adolescent female rowers. XXIVth Symposium of the International Society of Biomechanics in Sports, (Edited by H. Schwameder, G. Strutzenberger, V. Fastenbauer, S. Lidinger, E. Muller). pp. 355-358, The University of Salzburg.
- O'Sullivan, P. B. (2000). Lumbar segmental 'instability': clinical presentation and specific stabilizing exercise management. *Manual Therapy*, **5**, 2-12.

Appendix C – Conference Abstracts and Presentations

Title: Prevalence of low back pain in adolescent rowers

Questions: What is the prevalence of Low Back Pain (LBP) in adolescent rowers? **Design:** Quantitative survey design. **Participants:** One hundred and fifty-three male and 239 female adolescent rowers aged between 14 to 19 years who were competing in regular rowing regattas in Perth, Western Australia **Outcome measures:** Lifetime and point prevalence of LBP, self-reported factors associated with LBP onset and Visual Analogue Scale (VAS) for pain intensity **Results:** Lifetime prevalence of LBP was significantly higher in males 93.0% than females 63.1% ($p < 0.001$). Point prevalence was also higher in males 72.2% than females 45.8% ($p = 0.001$). The males mean VAS at the time of testing was significantly less 4.1 (2.3) than females 5.0 (2.0) ($p < 0.001$). Those rowers able to recall the provocative behaviours associated with their first incidence of LBP listed rowing activities such as ergometer rowing, lifting the boats and increased training load. **Conclusion:** Male and female adolescent rowers are at significant risk of LBP. This pain is typically of moderate intensity when they row, suggesting continued training and competition in the presence of pain. Furthermore, mechanical factors such as rowing posture and sudden change in training intensity are factors in the initial onset of LBP. The LBP prevalence reported in boys is higher than in female adolescent rowers suggesting gender related risk factors. Further research should be directed toward identifying the mechanisms associated with LBP in this population and structuring interventions to manage this condition.

Title: Gender differences in spinal kinematics during prolonged ergometer rowing in adolescence.

Question: Are there differences in spinal kinematics between adolescent males and females during prolonged ergometer rowing? **Design:** Within-participant (time) and between-subjects (gender) experimental study.

Participants: Ten healthy adolescent males and 10 adolescent female rowers aged between 14 to 19 years **Protocol:** Participants performed a 20-minute rowing ergometer trial at a rate of 22 strokes per minute at a 'very hard' intensity level. **Outcome measures:** Sacral angle (SA), Lower Lumbar Curvature (LLC), Upper Lumbar Curvature (ULC) and Thoracic Curvature (TC) were measured using an electromagnetic device. Stroke lengths and cycle durations were determined using a rotary encoder attached to the flywheel of a modified rowing ergometer. **Results:** Males had a faster drive phase than females; spending only 37.3% of their stroke in the drive phase compared to 41.9% for females ($p < 0.001$). The male's SA was postured more posteriorly than females ($p = 0.04$) and displayed a more flexed TC ($p = 0.04$). No differences were detected in the LLC ($p = 0.330$) or ULC ($p = 0.429$). Furthermore, males and females tilted their SA more posteriorly ($p < 0.001$), and more flexed in the ULC and TC ($p = 0.03$ and $p = 0.04$ respectively) from 1st to 20th minute. **Conclusion:** The results of this study identified that adolescent males typically sit in a more 'slouched' position than females during ergometer rowing. The more 'slouched' posture in spinal kinematics over the 20-minute ergometer trial is most likely the result of fatigue and supports previous research in adults. These findings may have implications for increased risk of LBP in male rowers and with prolonged rowing.

Title: Classification-based cognitive functional therapy intervention to alter spinal kinematics and reduce low back pain in an adolescent rower: case report

Questions: Previous research has reported that deficits in lumbar spine motor control resulting in increased end of range flexion strain is associated with LBP in rowers. However, to date there is no evidence that movement training interventions can alter the spinal kinematics of ergometer rowing and reduce pain. Therefore, the aim of this study was to investigate whether a cognitive functional intervention in an adolescent male rower with LBP, could alter the spinal kinematics and reduce LBP while ergometer rowing? **Design:** single case study report with an 8 week intervention and 12 week follow-up period. **Participants:** one male adolescent rower (17yo) classified with a flexion control disorder of the lumbar spine. **Intervention:** spino-pelvic kinematics assessment pre and post-treatment (12 weeks follow up). Classification-based cognitive functional therapy (5 sessions over 8 weeks) aimed to enhance lumbar spine flexion control during rowing. **Outcome measures:** Visual Analogue Scale questionnaire, Roland Morris Disability Questionnaire (RMDQ) and spino-pelvic kinematics during ergometer rowing. **Results:** Following the intervention there was an: increased anterior pelvic tilt, reduced lower lumbar flexion, increased upper lumbar flexion during ergometer rowing compared to pre-intervention. These changes were associated with reductions in LBP reported during ergometer rowing (VAS score initial = 6/10; follow up= 1/10) as well as reduced disability (RMDQ score: initial 52.2%; follow up = 4.3%). **Conclusion:** Although this data lends support that a cognitive functional approach may have the potential of changing spinal kinematics and reducing LBP during ergometer rowing, controlled research in a larger group is required to confirm these findings.

Appendix D – Ethical Approval

memorandum

To	Professor Peter O'Sullivan, Physiotherapy
From	A/Professor Stephan Millett, Chair, Human Research Ethics Committee
Subject	Protocol Approval HR 59/2010
Date	31 May 2010
Copy	Mr Leo Ng, Physiotherapy Dr Amity Campbell, Physiotherapy Graduate Studies Officer, Faculty of Health Sciences

Thank you for your application submitted to the Human Research Ethics Committee (HREC) for the project titled "*The spinal Kinematics in Prolonged Ergometer Rowing: Mechanical Etiology of Non-Specific Low Back Pain in adolescent Rowers*". Your application has been reviewed by the HREC and is **approved**.

- You have ethics clearance to undertake the research as stated in your proposal.
- The approval number for your project is **HR 59/2010**. Please quote this number in any future correspondence.
- Approval of this project is for a period of twelve months **26-05-2010 to 26-05-2011**. To renew this approval a completed Form B (attached) must be submitted before the expiry date **26-05-2011**.
- If you are a Higher Degree by Research student, data collection must not begin before your Application for Candidacy is approved by your Faculty Graduate Studies Committee.
- The following standard statement **must be** included in the information sheet to participants:
This study has been approved by the Curtin University Human Research Ethics Committee (Approval Number HR 59/2010). The Committee is comprised of members of the public, academics, lawyers, doctors and pastoral carers. Its main role is to protect participants. If needed, verification of approval can be obtained either by writing to the Curtin University Human Research Ethics Committee, c/- Office of Research and Development, Curtin University of Technology, GPO Box U1987, Perth, 6845 or by telephoning 9266 2784 or by emailing hrec@curtin.edu.au.

Applicants should note the following:

It is the policy of the HREC to conduct random audits on a percentage of approved projects. These audits may be conducted at any time after the project starts. In cases where the HREC considers that there may be a risk of adverse events, or where participants may be especially vulnerable, the HREC may request the chief investigator to provide an outcomes report, including information on follow-up of participants.

The attached **FORM B** should be completed and returned to the Secretary, HREC, C/- Office of Research & Development:

When the project has finished, or

- If at any time during the twelve months changes/amendments occur, or
- If a serious or unexpected adverse event occurs, or
- 14 days prior to the expiry date if renewal is required.
- An application for renewal may be made with a Form B three years running, after which a new application form (Form A), providing comprehensive details, must be submitted.

Regards,

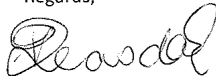

A/Professor Stephan Millett
Chair Human Research Ethics Committee



<p style="text-align: center;">An Examination of Lower Back Pain in Schoolboy Rowers – Survey for LBP</p>
--

Dear Participant,

Thank you for considering participating in this important study. We will be examining the number of schoolboy rowers suffering from low back pain and the likely causes that brought on their back pain.

Purpose

Recent research conducted in the private school girls in Perth found that schoolgirl rowers were 3 times more likely to suffer from low back pain than girls who did not row. Nearly half of the 300 rowers that participated in the survey complained of low back pain. At present, no such research has been done on schoolboy rowers. By knowing the scale of this problem, we may be able to determine the need and the method of reducing back pain in schoolboy rowers.

What is involved?

A survey that should take no more than 15 minutes to complete.

Confidentiality

You will be allocated an identification number that will remain confidential to the investigators and project supervisors. All the information will be entered using this identification number so your name will not appear on the documents. All the collected information and consent forms will be stored safely in a locked cupboard at the Curtin School of Physiotherapy, so that the research team are the only people with access to it.

Refusal or Withdrawal

You are free to not participate in the study. Also, if you do consent to participate you will be still free to withdraw from the study at any time without fear or prejudice. If you do decide to withdraw from the study please contact the investigators at the earliest possible convenience. All the information will be destroyed if you do decide to withdraw. Please contact Leo Ng on 0413 373 896 if you have any concerns or questions at any stage *during* your participation in this project.

Approval

This study has been approved by the Curtin University Human Research Ethics Committee (Approval Number HR 59/2010). The Committee is comprised of members of the public, academics, lawyers, doctors and pastoral carers. Its main role is to protect participants. If needed, verification of approval can be obtained by writing to the Curtin University Human Research Ethics Committee, c/- Office of Research and Development, Curtin University of Technology, GPO Box U1987, Perth, 6845, by telephoning 9266 2784 or by emailing hrec@curtin.edu.au.

Leo NG

Peter O'Sullivan

Angus Burnett

**An Examination of Lower Back Pain in Schoolboy Rowers –
Survey for LBP (Parents/Guardians)**

Dear Parents/Guardian

Your son has expressed interest in participating in a research project to determine the number of schoolboy rowers suffering from low back pain and the likely causes that brought on and provoke their back pain.

Purpose

Recent research conducted in the private school girls in Perth found that schoolgirl rowers were 3 times more likely to suffer from low back pain than girls who did not row. Nearly half of the 300 rowers that participated in the survey complained of low back pain. At present, no such research has been conducted on schoolboy rowers. By knowing the scale of this problem, we may be able to determine the need and the method of reducing back pain in schoolboy rowers.

What is involved?

A survey that should take no more than 15 minutes to complete.

Confidentiality

Your son will be allocated an identification number that will remain confidential to the investigators and project supervisors. All the information will be entered using this identification number so your son's name will not appear on the documents. All the collected information and consent forms will be stored safely in a locked cupboard at the Curtin School of Physiotherapy, so that the research team are the only people with access to it.

Refusal or Withdrawal

Your son is free to not participate in the study. Also, if you do consent to participate you will be still free to withdraw your son from the study at any time without fear or prejudice. If you do decide to withdraw from the study please contact the investigators at the earliest possible convenience. All data will be destroyed if you do decide to withdraw. Please contact Leo Ng on 0413 373 896 if you have any concerns or questions at any stage *during* your participation in this project.

Approval

This study has been approved by the Curtin University Human Research Ethics Committee (Approval Number HR 59/2010). The Committee is comprised of members of the public, academics, lawyers, doctors and pastoral carers. Its main role is to protect participants. If needed, verification of approval can be obtained by writing to the Curtin University Human Research Ethics Committee, c/- Office of Research and Development, Curtin University of Technology, GPO Box U1987, Perth, 6845, by telephoning 9266 2784 or by emailing hrec@curtin.edu.au. Thank you for considering participating in this important research.

Leo NG

Peter O'Sullivan

Angus Burnett

Appendix F – Consent Form



School of Physiotherapy

Subject Consent Form (Rowers)

Title of the Project: An Examination of Lower Back Pain in Rowers

Principal Investigator: Leo NG, PhD Candidate

Supervisors: Associate Professor Peter O'Sullivan,
Associate Professor Angus Burnett
School of Exercise, Biomedical and Health
Sciences,
Edith Cowan University

You have shown interest in participating in this research that can help improve the understanding of low back pain in rowers. Your signature verifies that you have decided to participate in this study, having read and understood all the information accessible. Your signature also officially states that you have had adequate opportunity to discuss this study with the investigators and all your questions have been answered to your satisfaction. You will be given a copy of this consent document to keep.

I, (the undersigned) _____

Please PRINT

of

Post code _____ Phone _____

*Consent to involvement in this study and give my authorisation for any results from this study to be used in any research paper, on the understanding that confidentiality will be maintained. I understand that I may withdraw from the study at any time without discrimination. If so, I undertake to contact **Leo Ng (Tel. 0413 373 896)** at the earliest opportunity.*

Signature _____ Date _____

Please note: You will also be required to return this form with a consent form signed by your parents / legal guardian.

I have explained to the subject the procedures of the study to which the subject/guardian has consented their involvement and have answered all questions. In my appraisal, the subject / guardian have voluntarily and intentionally given informed consent and possess the legal capacity to give informed consent to participate in this research study.

Signature : _____ Date: _____

Subject Consent Form (Parents/Guardian)

Title of the Project: An Examination of Lower Back Pain in Rowers

Principal Investigator: Leo NG, PhD Candidate,

Supervisors: Associate Professor Peter O'Sullivan,

Associate Professor Angus Burnett
School of Exercise, Biomedical and Health
Sciences,
Edith Cowan University

Your son is interested in participating in this research that can help improve the understanding of lower back pain in rowers. Your signature verifies that you have decided to allow your son/daughter to participate in this study, having read and understood all the information accessible. Your signature also officially states that you have had adequate opportunity to discuss this study with the investigators and all your questions have been answered to your satisfaction. You will be given a copy of this consent document to keep.

I, (the undersigned)

Please PRINT

of

Post code _____ Phone _____

I am the father / mother / guardian of

Please PRINT participant's name

*Consent to involvement in this study and give my authorisation for any results from this study to be used in any research paper, on the understanding that confidentiality will be maintained. I understand that I may withdraw from the study at any time without discrimination. If so, I undertake to contact **Leo Ng (Tel. 0413 373 896)** at the earliest opportunity.*

Signature _____ Date _____

I have explained to the subject the procedures of the study to which the subject/guardian has consented their involvement and have answered all questions. In my appraisal, the subject / guardian has voluntarily and intentionally given informed consent and possesses the legal capacity to give informed consent to participate in this research study.

Signature _____ Date _____

Appendix G – Low back pain & rowing questionnaire

Low Back Pain and Rowing Questionnaire

We invite you to complete the questionnaire below to help us understand Low Back Pain (LBP) in adolescent male rowers.

School: _____

Age (Please tick)

14	<input type="checkbox"/>
15	<input type="checkbox"/>
16	<input type="checkbox"/>
17	<input type="checkbox"/>
18	<input type="checkbox"/>
19	<input type="checkbox"/>

Rowing Experience (Please tick)

First Season	<input type="checkbox"/>
Second Season	<input type="checkbox"/>
Third Season	<input type="checkbox"/>
Fourth Season	<input type="checkbox"/>
Fifth Season	<input type="checkbox"/>
Sixth Season	<input type="checkbox"/>
> Six Seasons	<input type="checkbox"/>

Date of Birth: _____

Height (cms): _____

Weight (kg): _____

Prevalence Questions

Q1. Have you ever experienced lower back pain? Yes No

If no, skip to Question 5,

Q2, Do you currently experience lower back pain while rowing? Yes No

Pain Intensity Question

Q3 Please put a mark on the scale to show how bad your usual pain is in the last week.

|_____|
No Pain Worst Pain Possible

Rowing related aggravating Factors

Q4. Please place a tick in any of the boxes if you feel low back pain when doing any of the following activities

- | | |
|--|--|
| <input type="checkbox"/> Lifting a rowing shell. e.g. On and off the water, or loading the trailer | <input type="checkbox"/> Sweep rowing |
| <input type="checkbox"/> Rowing in a quadruple Scull | <input type="checkbox"/> Rowing in a single Scull |
| <input type="checkbox"/> Ergometer Rowing | <input type="checkbox"/> Long rows in a training session |
| <input type="checkbox"/> Weights session | <input type="checkbox"/> Prolonged sitting e.g. studying |
| <input type="checkbox"/> Other, please specify | |

Rowing related training hours

Q5. On average, how many hours per week do you participate in rowing training

On water	
On land	

Sports participation outside of rowing

Q6. On average, how many hours per week at the moment do you spend doing physical activity other than rowing?

0 hours	
Less than 5 hours	
Greater than 5 hour	

Appendix H – Ethical Approval

Ethical approval for study 3

memorandum

To	Dr Angus Burnett Physiotherapy
From	Dr Stephan Millett, Executive Officer, Human Research Ethics Committee
Subject	Protocol Approval HR 160/2006
Date	9 April 2013
Copy	Leo Ng, Physiotherapy Graduate Studies Officer, Division of Health Sciences

Curtin 
University of Technology

Office of Research and Development

Human Research Ethics Committee

TELEPHONE 9266 2784

FACSIMILE 9266 3793

EMAIL hrec@curtin.edu.au

Thank you for your application submitted to the Human Research Ethics Committee (HREC) for the project titled "*The Spinal Kinematics and Trunk Muscle Activity in Prolonged Ergometer Rowing: Mechanical Etiology of Non-Specific low back pain in female Adolescent rowers*". Your application has been reviewed by the HREC and is **approved**.

- You are authorised to commence your research as stated in your proposal.
- The approval number for your project is **HR 160/2006**. *Please quote this number in any future correspondence.*
- Approval of this project is for a period of twelve months **06-02-2007** to **06-02-2008**. To renew this approval a completed Form B (attached) must be submitted before the expiry date **06-02-2008**.
- If you are a Higher Degree by Research student, data collection must not begin before your Application for Candidacy is approved by your Divisional Graduate Studies Committee.

Applicants should note the following:

It is the policy of the HREC to conduct random audits on a percentage of approved projects. These audits may be conducted at any time after the project starts. In cases where the HREC considers that there may be a risk of adverse events, or where participants may be especially vulnerable, the HREC may request the chief investigator to provide an outcomes report, including information on follow-up of participants.

The attached **FORM B** should to be completed and returned to the Secretary, HREC, C/- Office of Research & Development:

When the project has finished, or

- If at any time during the twelve months changes/amendments occur, or
- If a serious or unexpected adverse event occurs, or
- 14 days prior to the expiry date if renewal is required.
- An application for renewal may be made with a Form B three years running, after which a new application form (Form A), providing comprehensive details, must be submitted.

Regards,

Dr Stephan Millett
Executive Officer
Human Research Ethics Committee

Please Note: The following standard statement must be included in the information sheet to participants:
This study has been approved by the Curtin University Human Research Ethics Committee. If needed, verification of approval can be obtained either by writing to the Curtin University Human Research Ethics Committee, c/- Office of Research and Development, Curtin University of Technology, GPO Box U1987, Perth, 6845 or by telephoning 9266 2784 or by emailing hrec@curtin.edu.au.

Appendix I – Information Sheets

<p style="text-align: center;">Study of Low Back Pain in People Participating in Rowing Information Sheet</p>

Dear Participant,

Thank you for participating in this study. We would like to take the opportunity to investigate the movement the spine adopts and the muscles used in a rowing action. This study also compares those participants with Low Back Pain (LBP) to those without LBP. We currently understand that differences exist from previous research subjects, however, this current research project uses state of the art technology to further understand this issue.

Why?

The reason we would like to carry out this project is to determine the difference angles of the spine during a rowing action. By understanding the differences between the two groups, we may lead to better prevention strategies and treatment strategies for clinicians.

What will be measured?

We will be measuring the position of the spine during the action of rowing. We will be measuring the movement for an hour as we suspect that the degree of movement in the spine will change with time. We will also be measuring the muscle activity during the cycling and rowing action.

What equipment will be used?

We will be using a machine known as the “3-Space Fastrak™” system, this system requires the placement of four small sensors in the spine (2 thoracic, 1 lumbar and 1 pelvis). The movement of these four sensors will be precisely measured using an electromagnetic field. This tracking device is not invasive, nor has it been associated with any side effects.

We will also be using electromyography (EMG), this is a system that analyses the activation of trunk muscles. In this study, we will be analysing six pairs of trunk muscles by carefully placing sensor on top of those muscles. Once again, these are non-invasive sensors, and have not been associated with any side effects.

Setting up – Participants will be required to disclose their body to a level of their underwear. Two physiotherapists with post-graduate qualification will diagnose the type of low back pain in the LBP group.

The skin where the sensors of all the “3-Space Fastrak™” and the EMG will be cleaned with alcohol (shaved if required) and then placed onto the skin using hypoallergenic tape.

What to wear?

The researchers will need to see the trunk of the body throughout testing. It is important for the participants to be in a state of semi-undress and expose their backs. A pair of shorts that can be positioned on the waist will be required and a crop top or bathers top. The dignity of the participants will be considered at all times.

What happens through the test?

Participants will be asked to fill out two questionnaires to determine the appropriateness of the subjects in this study. The subjects in the LBP group will be asked to perform a simply physical assessment test that involves;

Observation in standing

Bending forward in standing
Bending backwards in standing
Observation in sitting
Slouching forward in sitting

All participants will be asked to be set up to the “3-Space Fastrak™” and the EMG system as mentioned above. Participants will be asked to perform their sport while connected to this system.

Confidentiality

Subjects will be allocated an identification number that will remain confidential to the investigators and project supervisors. All data will be entered using this identification number, no names will be used. Access to the stored data will be known only to the investigators and the project supervisors only. All data collected and consent forms will be stored safely in a locked cupboard at the Curtin School of Physiotherapy.

How long will the tests take?

Approximately 2 hours

How will this information be used?

This information will be analysed to determine the difference in range of movement of movement and the muscles activation pattern of the lower back between individuals suffering from LBP and individuals without during rowing and cycling. It will provide important information to develop treatment strategies and injury prevention methods for elite athletes and amateur sports participants.

Should you have any questions with regards to this study, please feel free to contact us at any time. The first point of contact is Mr Leo Ng, the details are below.

We assure you that the information will be collected and kept under strict confidence. Curtin University and/or complaints regarding this study can be directed to the Human Research Ethics Committee Curtin University.

Dr Angus Burnett

Dr Peter O’Sullivan

Leo Ng
0413373896

Appendix J – Consent Forms



School of Physiotherapy

Subject Consent Form (Rowers)

Title of the Project: An Examination of Lower Back Pain in Rowers

Principal Investigator: Leo NG, PhD Candidate,

Supervisors: Associate Professor Peter O’Sullivan,
Associate Professor Angus Burnett
School of Exercise, Biomedical and Health Sciences,
Edith Cowan University

You have shown interest in participating in this research that can help improve the understanding of low back pain in rowers. Your signature verifies that you have decided to participate in this study, having read and understood all the information accessible. Your signature also officially states that you have had adequate opportunity to discuss this study with the investigators and all your questions have been answered to your satisfaction. You will be given a copy of this consent document to keep.

I, (the undersigned) _____

Please PRINT

of

Post code _____ Phone _____

*Consent to involvement in this study and give my authorisation for any results from this study to be used in any research paper, on the understanding that confidentiality will be maintained. I understand that I may withdraw from the study at any time without discrimination. If so, I undertake to contact **Leo Ng (Tel. 0413 373 896)** at the earliest opportunity.*

Signature _____ Date _____

Please note: You will also be required to return this form with a consent form signed by your parents / legal guardian.

I have explained to the subject the procedures of the study to which the subject/guardian has consented their involvement and have answered all questions. In my appraisal, the subject / guardian have voluntarily and intentionally given informed consent and possess the legal capacity to give informed consent to participate in this research study.

Signature : _____ Date: _____

Subject Consent Form (Parents/Guardian)

Title of the Project: An Examination of Lower Back Pain in Rowers

Principal Investigator: Leo NG, PhD Candidate,

Supervisors: Associate Professor Peter O'Sullivan,

Associate Professor Angus Burnett
School of Exercise, Biomedical and Health Sciences,
Edith Cowan University

Your son is interested in participating in this research that can help improve the understanding of lower back pain in rowers. Your signature verifies that you have decided to allow your son/daughter to participate in this study, having read and understood all the information accessible. Your signature also officially states that you have had adequate opportunity to discuss this study with the investigators and all your questions have been answered to your satisfaction. You will be given a copy of this consent document to keep.

I, (the undersigned)

Please PRINT

of _____

Post code _____ Phone _____

I am the father / mother / guardian of

Please PRINT participant's name

*Consent to involvement in this study and give my authorisation for any results from this study to be used in any research paper, on the understanding that confidentiality will be maintained. I understand that I may withdraw from the study at any time without discrimination. If so, I undertake to contact **Leo Ng (Tel. 0413 373 896)** at the earliest opportunity.*

Signature _____ Date _____

I have explained to the subject the procedures of the study to which the subject/guardian has consented their involvement and have answered all questions. In my appraisal, the subject / guardian has voluntarily and intentionally given informed consent and possesses the legal capacity to give informed consent to participate in this research study.

Signature _____ Date _____

Appendix K – Borg Rates of Perceived Exertion Scale

Rating	Interpretation
6	Rest - no exertion at all
7	Extremely light
8	*
9	Very light
10	*
11	Light
12	*
13	Somewhat hard
14	*
15	Hard
16	*
17	Very hard
18	*
19	Extremely hard
20	Maximal exertion

Borg, G (1970). Perceived exertion as an indicator of somatic stress. *Scandinavian Journal of Rehabilitative Medicine*, 2(3), pp. 92-98.

Appendix L – Screening Questionnaire

INITIAL LOW BACK PAIN QUESTIONNAIRE FOR ROWERS

Please draw on this body chart the location of your low back pain

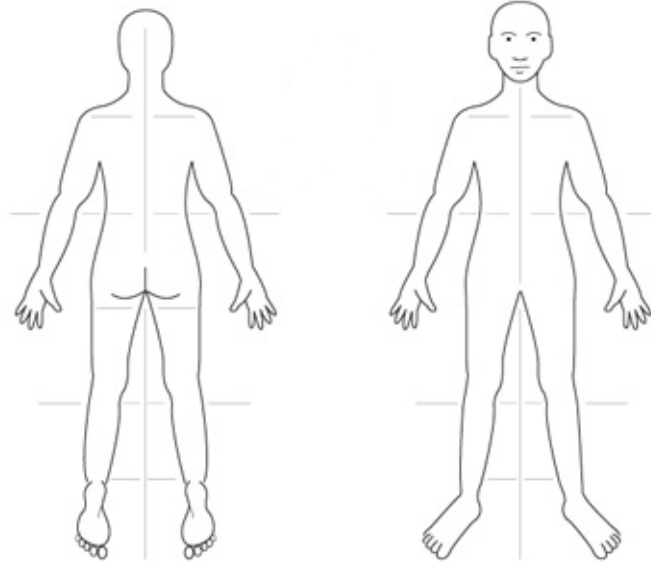

Please put an 'X' on the scale to show your level of pain you usually suffer

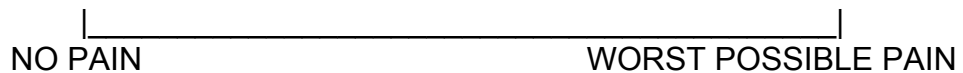

Do you typically suffer from low back pain *during on-water* training session? If so, after how long does it usually take to bring on your low back pain?

No () Yes () Time: _____

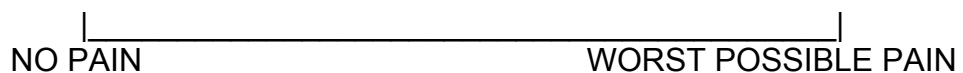

Do you typically suffer from low back pain *while* you are rowing on a rowing Ergometer? If so, after how long does it usually take to bring on your low back pain?

No () Yes () Time: _____

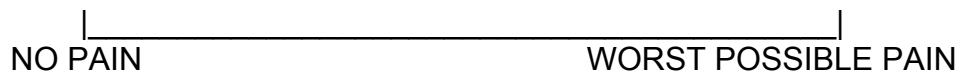

	YES	NO
1. Have you been given advice or diagnosis by a qualified medical professional with regards to your low back pain?		
2. Have you undertaken X-Ray, CT scan, Bone Scan or MRI that revealed a fracture or disc injuries?		
3. While you are rowing, do you suffer from pain or pins and needles at the back of your thigh or calves?		
4. Have you ever had back surgery?		
5. Have you been diagnosed with cancer?		
6. Have you missed school or days of work in the last 3 months as a result of low back pain?		
7. Have you received medical treatment for any musculoskeletal injuries in the last 6 weeks? If so, please list <hr/> <hr/> <hr/> <hr/>		
8. Have you suffered from injuries as a result of a motor vehicle accident? If so, please list <hr/> <hr/> <hr/> <hr/>		
9. Does your back pain increase within the first 30 minutes of your rowing session		

If you answered yes in any of the following questions, I may ask you further questions to understand the nature of your back pain.

Demographics Details

Identification Number:

Age:

Height:

Weight:

DOB:

Rowing Event (e.g. scull 4, sweep 8 ...):

Number of Hours of Training a week:

Number of years with Low Back Pain:

Appendix M – Roland-Morris Disability Questionnaire

The Roland-Morris Low Back Pain and Disability Questionnaire

When your back hurts, you may find it difficult to do some of the things you normally do.

This list contains some sentences that people have used to describe themselves when they have back pain. When you read them, you may find that some get your attention because they describe your situation *today*. As you read the list, think of yourself *today*. When you read a sentence that describes you *today*, put a checkmark in the box next to it. If the sentence does not describe you, then leave the box blank and go on to the next one. **Remember, checkmark the sentences only if you are sure that it describe you today.**

- I stay at home most of the day because of my back pain.
- I change my position frequently to allow my back to be more comfortable.
- I walk slower than usual because of my back pain.
- Because of my back pain, I am not doing any of the jobs that I usually do around the house.
- Because of my back pain, I use a handrail to get upstairs.
- Because of my back pain, I lie down to rest more often than usual.
- Because of the pain in my back, I have to hold on to something to get out of a lounge chair.
- Because of my back pain, I ask other people to do things for me.
- I get dressed slower than usual because of my back pain.
- I stand up only for short periods of time because of my back pain.
- Because of my back pain, I try not to bend over or kneel down.
- I find it difficult to get out of a straight-backed chair because of my back pain.
- My back is painful most of the day
- I find it difficult to turn over in bed because of my back pain.
- Because of my back pain, my appetite is not very good.
- I have trouble putting on my socks (or stockings) because of my back pain.
- Because of my back pain, I walk only short distances.
- I sleep less than usual because of my back pain.
- Because of my back pain, I get dressed with help from someone else.
- I spend most of the day sitting because of my back pain.
- I avoid heavy jobs around the house because of my back pain.
- Because of my back pain, I am more irritable and bad tempered than usual with people.
- Because of my back pain, I go upstairs slower than usual.
- I stay in bed most of the day because of my back pain.

Roland and Fairbank (2004) The Roland-Morris disability questionnaire and the Oswestry disability questionnaire, *Spine*, 25, pp. 3115-3124

Appendix N – Patient Specific Functional Scale

The Patient-Specific Functional Scale

Instructions:

Assessor to read and fill in.

Initial Assessment:

I am going to ask you to identify up to 3 important activities that you are unable to do or are having difficulty with as a result of your low back pain problem. Today, how difficult is it to perform activity 1 (have patient score this activity); 2 (have patient score this activity); 3 (have patient score this activity)

Follow-up Assessments:

When I assessed you on (state previous assessment date), you told me that you had difficulty performing these activities (read 1,2,3 from list). Today do you still have difficulty with activity 1 (have patient score this activity); 2 (have patient score this activity); 3 (have patient score this activity).

Scoring Scheme (show patient scale):

0	1	2	3	4	5	6	7	8	9	10
Unable to perform activity								Able to perform activity at the same level as before injury or problem		

	Date/Score	
Activity		

Startford P, Gill C, Westaway M, et al. Assessing disability and change on individual patients: a report of a patient specific measure. Physiotherapy Canada, 1995, 47, 258-263

Appendix O – Ethical Approval



Office of Research and Development

Human Research Ethics Committee

TELEPHONE 9266 2784

FACSIMILE 9266 3793

EMAIL hrec@curtin.edu.au

memorandum

To	Associate Professor Peter O'Sullivan,
From	A/Professor Stephan Millett, Chair, Human Research Ethics Committee
Subject	Protocol Approval HR 197/2008
Date	30 March 2009
Copy	Mr Leo Ng, Physiotherapy Associate Professor Angus Burnett, ECU Dr Amity Campbell, Physiotherapy

Thank you for providing the additional information for the project titled "*Efficacy of a Specific Physiotherapy Exercise Intervention to Alter Spinal Kinematics and Reduce Low Back Pain in Adolescent Male Rowers*". The information you have provided has satisfactorily addressed the queries raised by the Committee. Your application is now **approved**.

- You are authorised to commence your research as stated in your proposal.
- The approval number for your project is **HR 197/2008**. Please quote this number in any future correspondence.
- Approval of this project is for a period of twelve months **30-03-2009** to **30-03-2010**. To renew this approval a completed Form B (attached) must be submitted before the expiry date **30-03-2010**.
- If you are a Higher Degree by Research student, data collection must not begin before your Application for Candidacy is approved by your Divisional Graduate Studies Committee.
- The following standard statement **must be** included in the information sheet to participants:

This study has been approved by the Curtin University Human Research Ethics Committee (Approval Number HR 197/2008). The Committee is comprised of members of the public, academics, lawyers, doctors and pastoral carers. Its main role is to protect participants. If needed, verification of approval can be obtained either by writing to the Curtin University Human Research Ethics Committee, c/- Office of Research and Development, Curtin University of Technology, GPO Box U1987, Perth, 6845 or by telephoning 9266 2784 or by emailing hrec@curtin.edu.au.

Applicants should note the following:

It is the policy of the HREC to conduct random audits on a percentage of approved projects. These audits may be conducted at any time after the project starts. In cases where the HREC considers that there may be a risk of adverse events, or where participants may be especially vulnerable, the HREC may request the chief investigator to provide an outcomes report, including information on follow-up of participants.

The attached **FORM B** should be completed and returned to the Secretary, HREC, c/- Office of Research & Development:

When the project has finished, or

- If at any time during the twelve months changes/amendments occur, or
- If a serious or unexpected adverse event occurs, or
- 14 days prior to the expiry date if renewal is required.
- An application for renewal may be made with a Form B three years running, after which a new application form (Form A), providing comprehensive details, must be submitted.

Regards,

 A/Professor Stephan Millett
Chair Human Research Ethics Committee

Appendix P – Information Sheets

Effects of a Physiotherapy Exercise Program to Change Spinal Movement and Reduce Low Back Pain in Schoolboy Rowers (Rowers)

Rowing is one of the most prestigious sports in the Public School Association (PSA). However, research conducted on private schoolgirls in Perth found a large percentage of teenage rowers suffer from low back pain (LBP). We are currently trying to find out whether the same is the case for schoolboy rowers. Also, our team of researchers at Curtin University of Technology found a difference in spinal posture during ergometer rowing between rowers with pain compared to rowers without pain and that a specific treatment program could reduce back pain across the rowing season in schoolgirl rowers. We would now like to find out whether physiotherapy treatment can change the spinal postures and levels of pain during ergometer rowing in schoolboy rowers with low back pain.

What is involved?

Participation in this research is voluntary. Rowers with LBP will be recruited; half of them will undergo physiotherapy intervention while the other half will continue their usual rowing training. We will compare the amount of pain experienced by the rowers and the spinal posture during an ergometer trial between the two groups before and after the intervention program.

Part 1 - Screening of your Low Back Pain

Even though you have LBP, you still may not be suitable for this study if your pain is not provoked by rowing. We are wishing to only examine rowers who have LBP related to rowing. Prior to the rowing testing itself (one to two weeks prior), you will be asked to fill out two questionnaires and to perform a simple physical assessment test that will involve sitting postures, standing postures and simulated rowing postures. A physiotherapist with post-graduate qualifications will undertake this assessment on you. This test will have to be filmed, so that a second physiotherapist can confirm the findings. This footage will not be used for any other purpose but confirmation of the physical assessment.

Part 2 – First Ergometer Trial

During the rowing ergometer trial we will be measuring the movement of your back for approximately 20 minutes as we suspect that it will change with time. You will be asked to row at a level you are accustomed to during your rowing training. During this trial, you may experience low back pain at a level similar to that your experience during your usual training sessions. If it gets too painful, testing will stop immediately.

Part 3 – Intervention

Half of the 40 rowers will be randomly allocated to undergo physiotherapy exercise therapy. For those allocated to physiotherapy treatment group, they will require to undergo an initial examination followed by the physiotherapist giving you a specific movement and strengthening exercise program. You will be expected to do these exercises 5 times a week over a period of 8 weeks and you will be required to fill in a form to confirm this. Failure to complete these exercises may result in your withdrawal from the study. The physiotherapists providing the treatments all hold a post-graduate degree in physiotherapy and have experience in the assessment and treatment of

rowers with low back pain. Although the supervisor for this project Associate Professor Peter O'Sullivan works and owns Body Logic Physiotherapy, he will not directly gain financial benefits from this study. Rowers not allocated in the treatment group will continue with training as per usual.

Part 4 – Second Ergometer Trial

After about 8 weeks from the first ergometer trial, all 40 rowers will have a second ergometer trial, where the testing procedures will be the same as the first ergometer trial. That is, measuring the movement of your back for approximately 20 minutes during an ergometer trial. The level of pain will once again be collected and if it exceeds the level you normally experience during your usual training session, testing will stop immediately.

What equipment will be used?

To measure the movement of your back we will be using a machine known as the “3-Space Fastrak™”. This system requires the placement of four small sensors, using double sided tape, over specific areas of the back (one mid back, one low back, one pelvis and one thigh). This tracking device is completely safe and does not involve pain on application or removal.

What to wear?

The researchers will need to see your back throughout testing. Also, so we can attach the testing equipment to you, you will be required to wear tight fitting sports shorts (something made of lycra or similar fitting materials will be best). Your dignity will be considered at all times.

Confidentiality

You will be allocated an identification number that will remain confidential to the investigators and project supervisors. All data will be entered using this identification number so no names will be used. Access to the stored data will only be to the investigators. All collected information and consent forms will be stored safely in a locked cupboard at the Curtin University, School of Physiotherapy.

How long will the tests take?

The ergometer trials should take 30 minutes. The physiotherapy sessions should take an hour in the first session and about 30 minutes in the following visits.

How will this information be used?

The information collected from this study will be analysed to determine the posture of the low back during ergometer rowing. It will provide important information to develop treatment strategies and injury prevention methods for elite athletes and amateur sports participants. Should you have any questions with regards to this study, please feel free to contact us at any time. The first point of contact is Mr Leo Ng and the contact details are below.

Refusal or Withdrawal

You are free to not participate in the study. Also, if you do consent to participate you will be still free to withdraw from the study at any time without fear or prejudice. If you do decide to withdraw from the study please contact the investigators at the earliest possible convenience. All collected information will be destroyed if you do decide to withdraw. Please contact Leo Ng on 0413 373 896 if you have any concerns or questions at any stage.

Approval

This study has been approved by the Curtin University Human Research Ethics Committee (Approval Number HR 197/2008). The Committee is comprised of members of the public, academics, lawyers, doctors and pastoral carers. Its main role is to protect

participants. If needed, verification of approval can be obtained either by writing to the Curtin University Human Research Ethics Committee, c/- Office of Research and Development, Curtin University of Technology, GPO Box U1987, Perth, 6845 or by telephoning 9266 2784 or by emailing hrec@curtin.edu.au.

Leo Ng

Peter O'Sullivan

Angus Burnett

**Effects of a Physiotherapy Exercise Program to Change Spinal
Movement and Reduce Low Back Pain in Schoolboy Rowers**

Purpose

Rowing is one of the most prestigious sports in the Public School Association (PSA). However, research conducted on private schoolgirls in Perth found a large percentage of teenage rowers suffer from low back pain (LBP). We are currently trying to find out whether the same is the case for schoolboy rowers. Also, our team of researchers at Curtin University of Technology found a difference in spinal posture during ergometer rowing between rowers with pain compared to rowers without pain and that a specific treatment program could reduce back pain across the rowing season in schoolgirl rowers. We would now like to find out whether physiotherapy treatment could change the spinal postures and levels of pain during ergometer rowing in schoolboy rowers with low back pain.

What is involved?

Participation in this research is voluntary, and your son has shown interest in participating in this study. Rowers with LBP will be recruited; half of them will undergo physiotherapy intervention while the other half will continue their usual rowing training. We will compare the amount of pain experienced by the rowers and the spinal posture during an ergometer trial between the two groups before and after the intervention program.

Part 1 - Screening of your Low Back Pain

Even though your son has LBP, he may still not be suitable for this study if his pain is not provoked by rowing. We are wishing to only examine rowers who have LBP related to rowing. Prior to the rowing testing itself (one to two weeks prior), he will be asked to fill out two questionnaires and asked to perform a simple physical assessment test that will involve sitting postures, standing postures and simulated rowing postures. A physiotherapist with post-graduate qualifications will undertake this assessment on him. This test will have to be filmed, so that a second physiotherapist can confirm the findings. This footage will not be used for any other purpose but confirmation of the physical assessment.

Part 2 – First Ergometer Trial

During the rowing ergometer trial we will be measuring the movement of his back for approximately 20 minutes as we suspect that it will change with time. Your son will be asked to row at a level at a level he is accustomed to during his rowing training. During this trial, your son may experience low back pain at a level similar to that experienced during his usual training sessions. If it gets too painful, testing will stop immediately.

Part 3 – Intervention

Half of the 40 rowers will be randomly allocated to undergo physiotherapy exercise therapy. For those allocated to physiotherapy treatment group, they will require to undergo an initial examination followed by the physiotherapist giving your son a specific movement and strengthening exercise program. Your son will be expected to do these exercises 5 times a week over a period of 8 weeks and he will be required to fill in a form to confirm this. Failure to complete these exercises may result in your withdrawal from the study. The physiotherapists providing the treatments all hold a post-graduate

degree in physiotherapy and have experience in the assessment and treatment of rowers with low back pain. Although the supervisor for this project Associate Professor Peter O'Sullivan works and owns Body Logic Physiotherapy, he will not directly gain financial benefits from this study. The money will be allocated to the treating physiotherapists at a substantially reduced price for the benefit of this research. Rowers not allocated in the treatment group will continue with training as per usual.

Part 4 – Second Ergometer Trial

After about 8 weeks from the first ergometer trial, all 40 rowers will have a second ergometer trial, where the testing procedures will be the same as the first ergometer trial. That is, measuring the movement of your back for approximately 20 minutes during an ergometer trial. The level of pain will once again be collected and if it exceeds the level you normally experience during your usual training session, testing will stop immediately.

What equipment will be used?

To measure the movement of your son's back we will be using a machine known as the "3-Space Fastrak™". This system requires the placement of four small sensors, using double sided tape, over specific areas of the back (one mid back, one low back, one pelvis and one thigh). This tracking device is completely safe and does not involve pain on application or removal.

What to wear?

The researchers will need to see your back throughout testing. Also, so we can attach the testing equipment to you, your son will be required to wear tight fitting sports shorts (something made of lycra or similar fitting materials will be best). Your son's dignity will be considered at all times.

Confidentiality

Your son will be allocated an identification number that will remain confidential to the investigators and project supervisors. All data will be entered using this identification number so no names will be used. Access to the stored data will only be to the investigators. All collected information and consent forms will be stored safely in a locked cupboard at the Curtin University, School of Physiotherapy.

How long will the tests take?

The ergometer trials should take 30 minutes. The physiotherapy sessions should take an hour in the first session and about 30 minutes in the following visits.

How will this information be used?

The information collected from this study will be analysed to determine the posture of the low back during ergometer rowing. It will provide important information to develop treatment strategies and injury prevention methods for elite athletes and amateur sports participants. Should you have any questions with regards to this study, please feel free to contact us at any time. The first point of contact is Mr Leo Ng and the contact details are below.

Refusal or Withdrawal

You and your son are free to not participate in the study. Also, if you do consent to participate you will be still free to withdraw from the study at any time without fear or prejudice. If you do decide to withdraw your son from the study please contact the investigators at the earliest possible convenience. All collected information will be destroyed if you do decide to withdraw. Please contact Leo Ng if you have any questions at any stage.

Approval

This study has been approved by the Curtin University Human Research Ethics Committee (Approval Number HR 197/2008). The Committee is comprised of members

of the public, academics, lawyers, doctors and pastoral carers. Its main role is to protect participants. If needed, verification of approval can be obtained either by writing to the Curtin University Human Research Ethics Committee, c/- Office of Research and Development, Curtin University of Technology, GPO Box U1987, Perth, 6845 or by telephoning 9266 2784 or by emailing hrec@curtin.edu.au

Leo NG

Peter O'Sullivan

Angus Burnett

No-Treatment Group

Dear Participant,

Thank you for participating in this important research to determine the effectiveness of an exercise program to reduce low back pain in rowers. You have been selected in the no-treatment group. You will shortly be invited to undertake physical ergometer testing at your rowing club. This testing will analyse the movement in your low back as you row on an ergometer. Please read the information sheet attached in this envelope carefully and return a signed consent form from you and your parents (guardian) and return during the physical ergometer testing session. Please do not bring this sheet or reveal whether you are in the intervention or no-intervention group to the examiner.

You will be asked to continue your usual training with your coaches in your rowing club. After 8 weeks, you will be asked to undertake the physical ergometer testing at your school again to compare the movement in your lower back and determine any changes in pain behaviour as a result of your rowing training.

Thank you once again for your participation; we hope the results can reduce low back pain in rowers in the adolescent population in the future.

Kind regards,

Leo NG

Treatment Group

Dear Participant,

Thank you for participating in this important research to determine the effectiveness of an exercise program to reduce low back pain in rowers. You have been selected in the treatment group. You will shortly be invited to undertake physical ergometer testing at your rowing club. This testing will analyse the movement in your low back as you row on an ergometer. Please read the information sheet attached in this envelope carefully and return a signed consent form from you and your parents (guardian) and return during the physical ergometer testing session. Please do not bring this sheet or reveal whether you are in the intervention or no-intervention group to the examiner.

After the physical ergometer testing, you will undergo 5 physiotherapy sessions by an experienced physiotherapist for the treatment of low back pain. During these sessions, the physiotherapist will perform a detail interview and physical assessment to determine the mechanism of your low back pain. During the physical assessment, the physiotherapist may ask you to disrobe to the level of your shorts to reduce obstruction of your lower back during observation. An exercise program will be written out by the physiotherapist for you. We ask that you carry out these exercises as prescribed by the physiotherapist and continue your usual training at the rowing club. It is anticipated that your first session will be an hour and subsequent visits will be 30 minutes in duration.

Following the physical ergometer session, can you please contact Bodylogic Physiotherapy for an appointment with a physiotherapist. The phone number is (08) 9381 7940. The address is 215 Nicholson Rd, Shenton Park, WA 6008.

Finally, shortly after your final treatment session, you will be asked to undertake physical ergometer testing again at your school to compare the movement in your lower back and the effect treatment has on your back pain.

Thank you once again for your participation, we hope the results of this study can reduce low back pain in rowers in the teenage population in the future.

Kind regards,

Leo NG

Subject Consent Form (Rowers)

Title of the Project: Effects of a physiotherapy program to reduce low back pain in rowers

Principal Investigator: Leo NG, PhD Candidate,

Supervisors: Associate Professor Peter O'Sullivan,

Associate Professor Angus Burnett
School of Exercise, Biomedical and Health Sciences,
Edith Cowan University

You have shown interest in participating in this research that can help improve the understanding of low back pain in rowers. Your signature verifies that you have decided to participate in this study, having read and understood all the information accessible. Your signature also officially states that you have had adequate opportunity to discuss this study with the investigators and all your questions have been answered to your satisfaction. You will be given a copy of this consent document to keep.

I, (the undersigned) _____

Please PRINT

of

Post code _____ Phone _____

*Consent to involvement in this study and give my authorisation for any results from this study to be used in any research paper, on the understanding that confidentiality will be maintained. I understand that I may withdraw from the study at any time without discrimination. If so, I undertake to contact **Leo Ng (Tel. 0413 373 896)** at the earliest opportunity.*

Signature _____ Date _____

Please note: You will also be required to return this form with a consent form signed by your parents / legal guardian.

I have explained to the subject the procedures of the study to which the subject/guardian has consented their involvement and have answered all questions. In my appraisal, the subject / guardian have voluntarily and intentionally given informed consent and possess the legal capacity to give informed consent to participate in this research study.
Signature : _____ Date: _____

Subject Consent Form (Parents/Guardian)

Title of the Project: Effects of a physiotherapy program to reduce low back pain in rowers

Principal Investigator: Leo NG, PhD Candidate,

Supervisors: Associate Professor Peter O'Sullivan,

Associate Professor Angus Burnett
School of Exercise, Biomedical and Health Sciences,
Edith Cowan University

Your son is interested in participating in this research that can help improve the understanding of lower back pain in rowers. Your signature verifies that you have decided to allow your son/daughter to participate in this study, having read and understood all the information accessible. Your signature also officially states that you have had adequate opportunity to discuss this study with the investigators and all your questions have been answered to your satisfaction. You will be given a copy of this consent document to keep.

I, (the undersigned)

Please PRINT

of _____

Post code _____ Phone _____

I am the father / mother / guardian of

Please PRINT participant's name

*Consent to involvement in this study and give my authorisation for any results from this study to be used in any research paper, on the understanding that confidentiality will be maintained. I understand that I may withdraw from the study at any time without discrimination. If so, I undertake to contact **Leo Ng (Tel. 0413 373 896)** at the earliest opportunity.*

Signature _____ Date _____

I have explained to the subject the procedures of the study to which the subject/guardian has consented their involvement and have answered all questions. In my appraisal, the subject / guardian has voluntarily and intentionally given informed consent and possesses the legal capacity to give informed consent to participate in this research study.

Signature _____ Date _____