

*Identification of textile fibres, Max Houck (ed) Woodhead Publishing, Cambridge, 2009, pp 203- 223*

## **Chapter 11: Analysis of dyes using chromatography**

S.W. Lewis

Curtin University of Technology, Australia

**Abstract:** The colour of fibre, present naturally or imparted through use of a dye or pigment, can be extremely discriminating for the forensic scientist. One approach for colour analysis available to the forensic scientist is chromatography and, while partially destructive of the evidence, it can provide a much greater degree of discrimination than physical or optical methods alone. This chapter will give an overview of chromatographic methods applied to the forensic analysis of dyes in fibres focusing on thin-layer chromatography (TLC). Other approaches to instrumental chromatographic analysis of dyes, including high performance liquid chromatography (HPLC) and capillary electrophoresis (CE) will also be discussed.

**Keywords:** forensic fibre dye analysis, thin-layer chromatography, extraction, high performance liquid chromatography, capillary electrophoresis

### **11.1 Introduction**

A key element of a fibre's functionality is its colour, which can be extremely discriminating for the forensic scientist. This colour may be present naturally or can be imparted through use of a dye or pigment. As described in Chapter 9, microspectrophotometry can provide a good deal of differentiation; however, in a small number of cases, different dyes may produce the same or similar colour.(Wiggins et al., 2005) One approach available to the forensic scientist is chromatography and, while partially destructive of the evidence, it can provide a much greater degree of discrimination than physical or optical methods alone. Chromatographic methods require the extraction of the colourant from the fibre followed by analysis. This chapter will give an overview of chromatographic methods applied to the forensic analysis of dyes in fibres focussing on thin-layer chromatography (TLC) which is the most widely used chromatographic technique applied in this area. Other approaches to instrumental chromatographic analysis of dyes that have been suggested, including high performance liquid chromatography (HPLC) and capillary electrophoresis (CE) will also be discussed.

### **11.2 Dyes**

Dyes have been used to alter the appearance of cloth and fabric by changing their colour since ancient times.(Garfield, 2000) Dyes can be defined as any substance which has an affinity for a substrate and, on binding to that substrate, alters the way in which the material absorbs light, and hence changes the colour that is

subsequently observed. Dying of cloth with a wide variety of vegetable and animal dyes has been carried out for thousands of years. Famous historical dyes include the rare and expensive Royal Purple, extracted from certain species of mollusc and used by the Roman emperor and his household; cochineal, the crimson dye obtained from the dried and pulverised bodies of cactus insects; and indigo sourced from the leaves of certain plants.(Garfield, 2000) The birth of modern dyestuffs occurred with the discovery of mauveine by William Perkin in 1856 and today synthetic dyes predominate.(Gregory, 2000, Garfield, 2000)

Colour is due to the preferential absorption of certain wavelengths of light, the observed colour being those wavelengths of light that are reflected. The particular bands of light absorbed, and hence the colour observed, by a particular dyed fabric is due to the chemical structure of the dye. Light is absorbed by a molecule when it has sufficient energy to promote an electron from a ground state orbital, where electrons within a molecule normally reside, to an unoccupied higher energy orbital. Dyes are organic molecules with extensive areas of high electron density due to the presence of double bonds. When the double bonds alternate along the structure the molecule is said to be conjugated. This leads to overlapping  $\pi$  orbitals, which results in decreased energy gaps between ground state and higher energy, unoccupied orbitals. The areas of a molecule that absorb visible light are termed chromophores, the wavelengths of light they absorb will depend on their structure and the presence of other groups, termed auxochromes, which alter the electron density within the conjugated group.

For a chemical to act as a dye it must have some affinity for the substrate to which it is being applied. Dyes can be bound either physically, through a variety of different attractive forces such ionic, van der Waal's, and hydrogen bonding, or chemically, through covalent bonds.(Gregory, 2000)

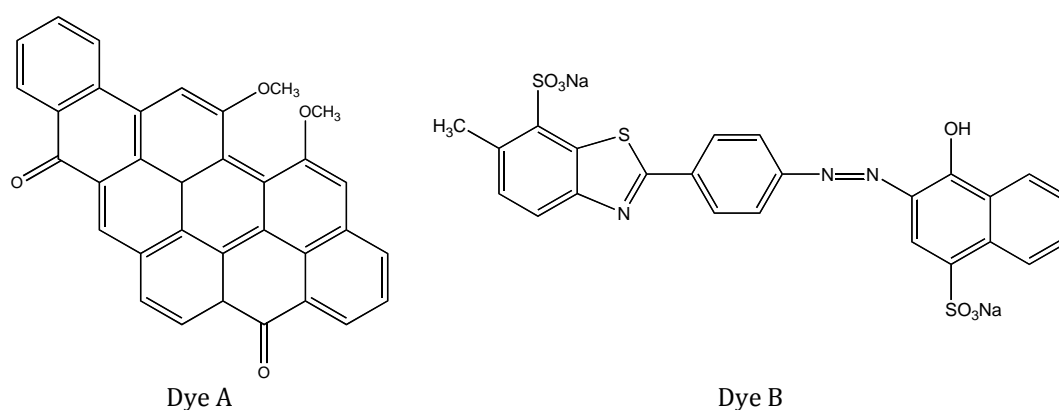
Classification and identification of individual dyes is complicated by the bewildering array of chemical structures, methods of application, and commercial names.(Gregory, 2000) One of the best known sources of information on dyes is the Colour Index, which was first published by the Society of Dyers and Colourists in 1925 and is now available in an On-line version.([www.colour-index.org](http://www.colour-index.org), 2007) This utilises a dual system of numbers and names to classify dyes and pigments, based primarily on the method of application, which are listed in Table 11.1.

**Table 11.1 Dye classes and associated fibres**

Class	Fibre Type	Method of application
Acid	Wool, silk, polyamide, protein, polyacrylonitrile, polypropylene	Acidic dyebaths
Azoic	Cotton, viscose	Fibre impregnated with coupling component and treated with stabilised diazonium salt
Basic	Polyacrylonitrile, modified acrylic, polyester, polyamide	Acidic dyebaths
Direct	Cotton, viscose	Neutral or slightly alkaline dyebath containing additional electrolyte
Disperse	Polyester, polyacrylonitrile, polyamide, polypropylene, acetate/triacetate	Aqueous dispersion of dye, often applied at high temperatures or in the presence of a carrier
Metallized	Wool, polypropylene	Formation of a metal complex, dye, metal (mordant) may be applied before, after or at same time as dye
Reactive	Cotton, wool, polyamide	Dye reacts chemically with fibre forming covalent bonds, may be under acid or alkaline conditions
Sulfur	Cotton	Dyes reduced in alkaline medium to produced leuco form of dye which penetrates fibre and then is oxidised back to insoluble form of dye
Vat	Cotton	Complex process similar to sulfur dyes

From (Gregory, 2000, Wiggins, 1999)

The following examples illustrate classification of the dyes illustrated in Fig 11.1. Dye A is CI Vat Green 1, CI Number 59825, indicating that its method of application is via a vat dyeing process. Dye B is CI Direct Red 45, CI Number 14780 which is applied directly to the fibres.

**Figure 11.1 Chemical Structures of Selected Dyes**

One disadvantage of this classification process is that it does not provide information concerning the chemical structure of the dye, which is essential in developing analytical chemistry procedures for their extraction, separation and identification. In terms of chemical properties the unique identifier for the each

dye is the Chemical Abstracts Service (CAS) Registry number, for example for Dye A in Fig 11.1. this is 128-58-5. This number can be used for searching in on-line databases like Scifinder Scholar.

Due to the variation in chemical structure of fibres, some dyes are more suited for use with certain fibres. For example acid dyes are particularly well suited to the dyeing of wool and nylon due to the presence of the amino groups that are charged under acid conditions thus attracting the dye anion.(Wiggins, 1999) The Metropolitan Laboratory of the Forensic Science Service in the UK carried out a study on fibre/dye combinations encountered during a 12 month period from 1993 to 1994 and discovered that while certain combinations were more prevalent, it was clear that many dyes are available for each of the fibre types commonly encountered in forensic examinations.(Wiggins, 1999) It should also be noted that most textiles are dyed with multiple dyes, and due to the complexity of the dyeing process, this occurs via a batch process. This leads to variability in colour between batches.(Connelly, 1997, Wiggins et al., 1987) This may be useful to the forensic scientist, but also leads to complications in developing protocols for the analysis of dyes in unknown samples.

### **11.3 Forensic Analysis of Dyes**

As stated above, fibres are most likely to be dyed with a combination of several different dyes. This combination has the potential to be characteristic of a particular source of fibres. Forensic analysis of dyes is thus generally carried out to compare recovered samples with controls, rather than to absolutely identify a particular dye. The two issues which face the forensic analyst when considering the analysis of fibre dyes are;

- (i) the sheer complexity of the problem with the wide variety of dyes and fibres and potential combinations thereof, and
- (ii) the destructive nature of chromatographic analysis due to the extraction of the dye from the fibre.

It is for these reasons that extraction and analysis of dye from fibres is only carried out once the other physical and optical methods of analysis have been exhausted.

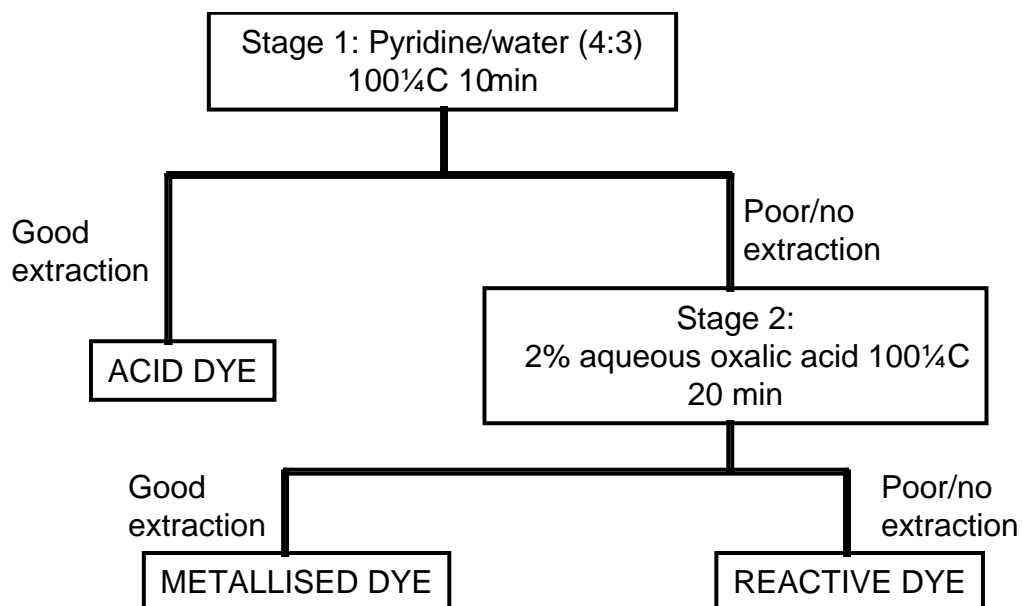
#### *11.3.1 Extraction*

The first step in the analytical process is extraction of the dye/dyes from the fibre. A number of different extraction schemes utilising a variety of solvents have been proposed.(Beattie et al., 1981a, Beattie et al., 1979, Beattie et al., 1981b, Cheng et al., 1991, Hartshorne and Laing, 1984, Home and Dudley, 1981, Laing et al., 1991, Laing et al., 1990, Macrae and Smalldon, 1979, Resua, 1980, West, 1981, Wiggins, 1999) These schemes vary in detail, but have essentially the same goal of using a sequence of extractions, which not only provide an extract of the dye but can also be used to classify the dye. A comprehensive approach is that developed by the Forensic Science Service in the United

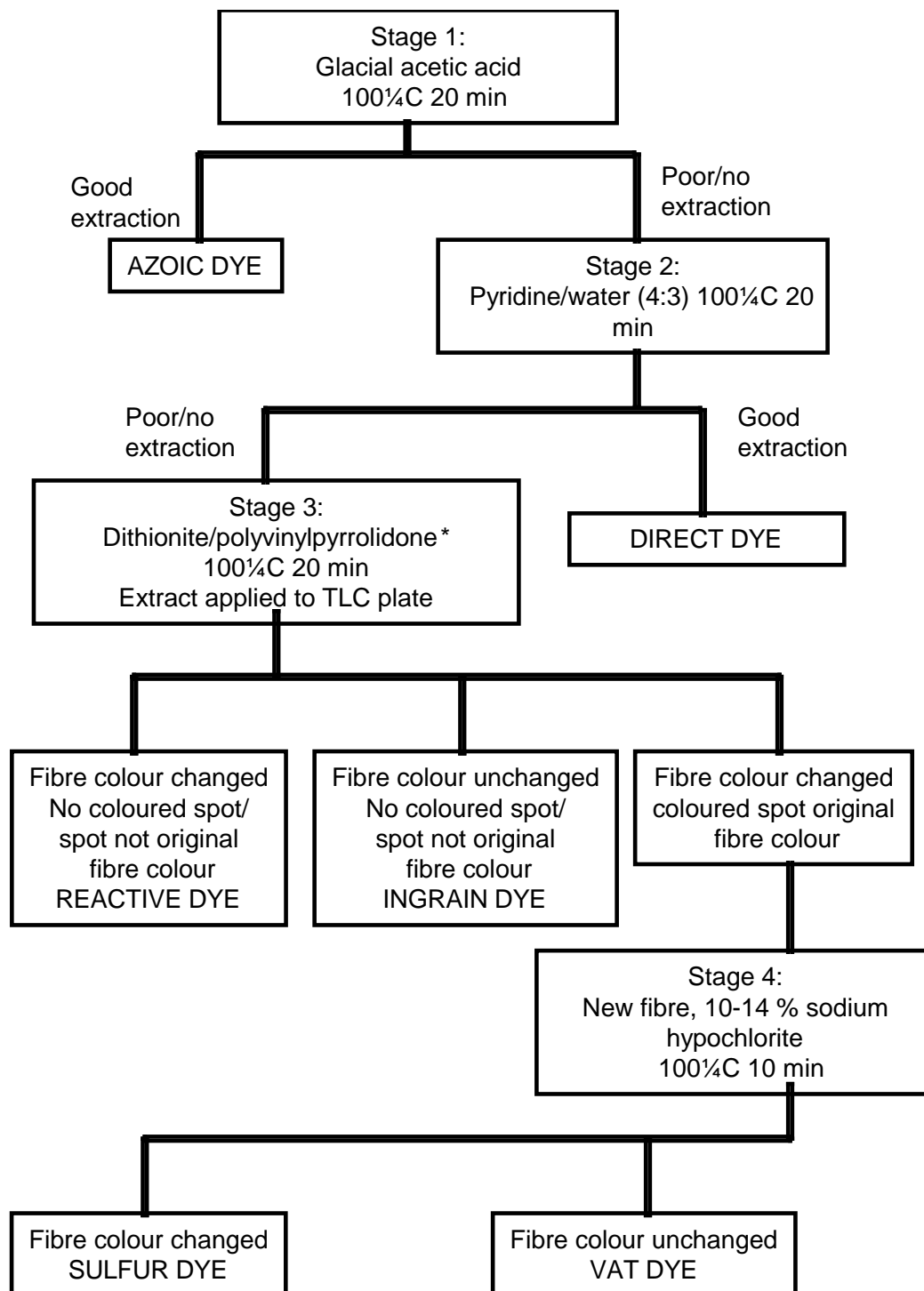
Kingdom which involves different solvent sequences depending on the identity of the fibre, which had been established by microscopy and/or infrared spectrophotometry.(Wiggins, 1999) Subsequent separation and identification of the dyes was by thin layer chromatography (TLC). Details of the various extraction schemes are summarised in Figures 11.2 to 11.7.(Wiggins, 1999)

The extraction process itself is very simple. A single fibre is placed in a glass tube (2.5 cm x 1.5 mm i.d.), sealed at one end. Solvent (around 10 µL, it should be sufficient to completely immerse the fibre) is added and the tube is heat sealed prior to incubation in an oven for the requisite time and temperature, as described in the extraction procedure.(Wiggins, 1999) If the fibre is very pale a larger sample than a single fibre is needed, due to sensitivity issues. Control samples are utilised in order to establish dye class and the best extraction procedure prior to analysis of recovered fibres.(Wiggins, 1999). Once classification of the dye has occurred via the schemes described in Figures 11. 2 to 11.7, extraction for TLC analysis can be carried out as outlined in Table 11.2.

Care must be taken when using this approach to characterise dye classes in unknown samples, with dyes being classified as “being equivalent to, or acting as, a particular dye class”.(Wiggins, 1999) This covers the possibility if new dyes are introduced. This scheme as originally proposed did not account for reactive, vat, ingrain and sulfur dyes which were not considered extractable.

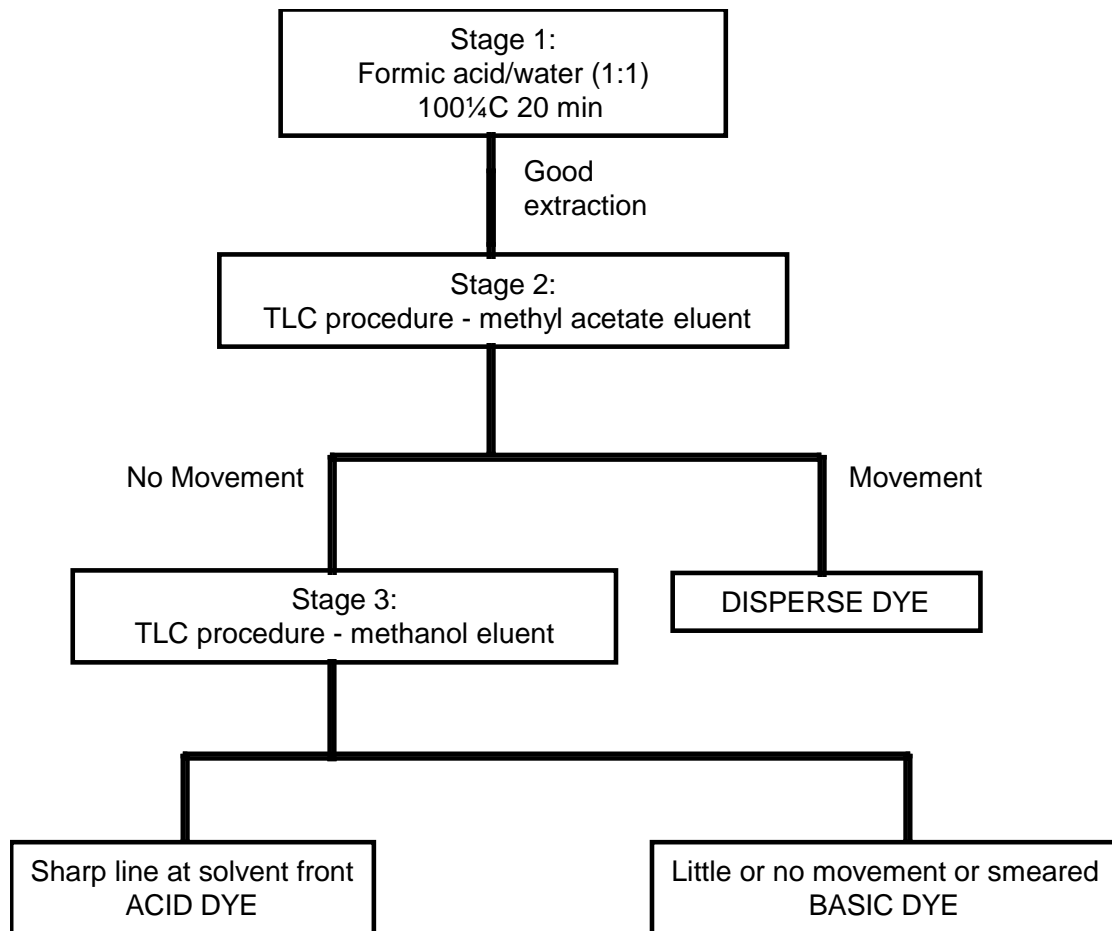


**Figure 11.2 Extraction and classification of dye from wool fibres (Wiggins, 1999)**

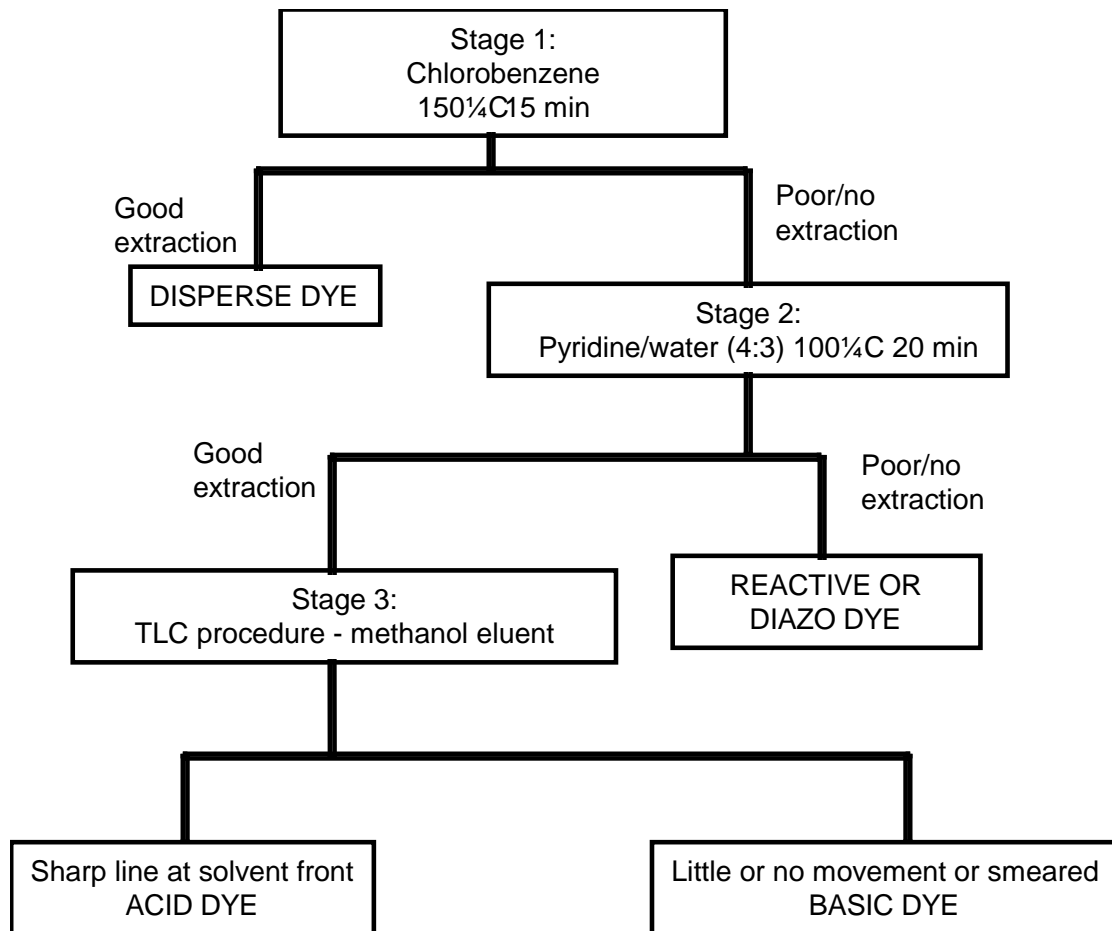


\*sodium dithionite (80 mg) polyvinylpyrrolidone (30 mg) sodium hydroxide (10 %, 450 µL) water (9 mL); use immediately and discard excess

**Figure 11.3 Extraction and classification of dyes from cotton and viscose fibres (Wiggins, 1999)**

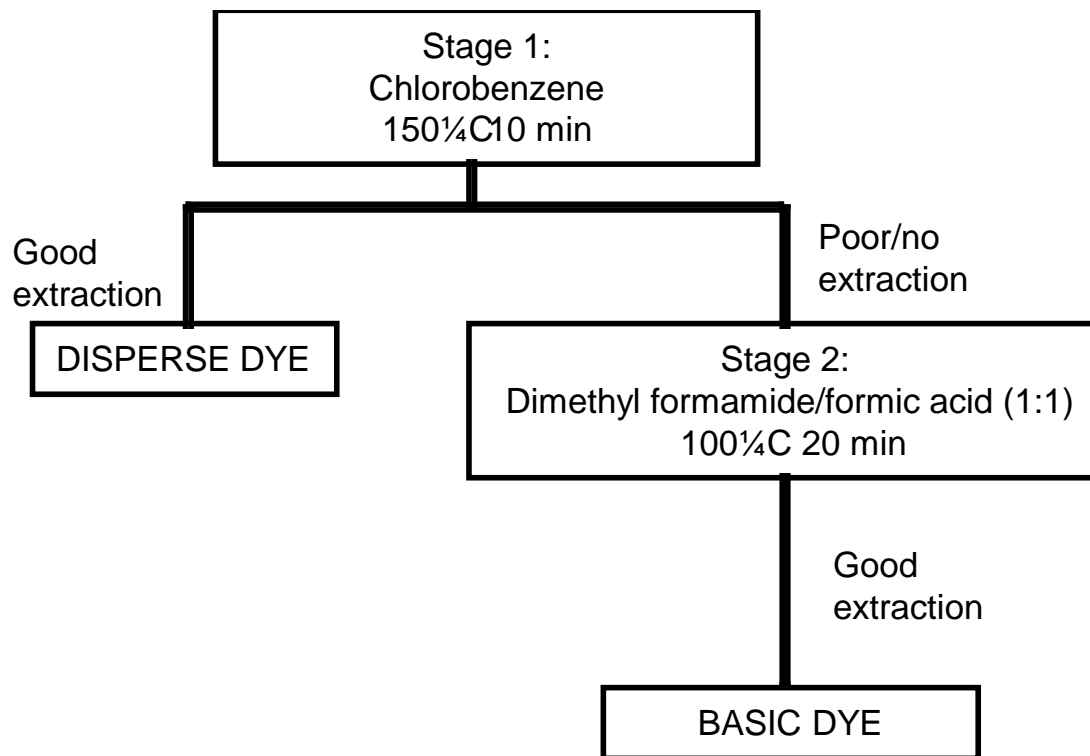


**Figure 11.4 Extraction and classification of dyes from polyacrylonitrile fibres (Wiggins, 1999)**

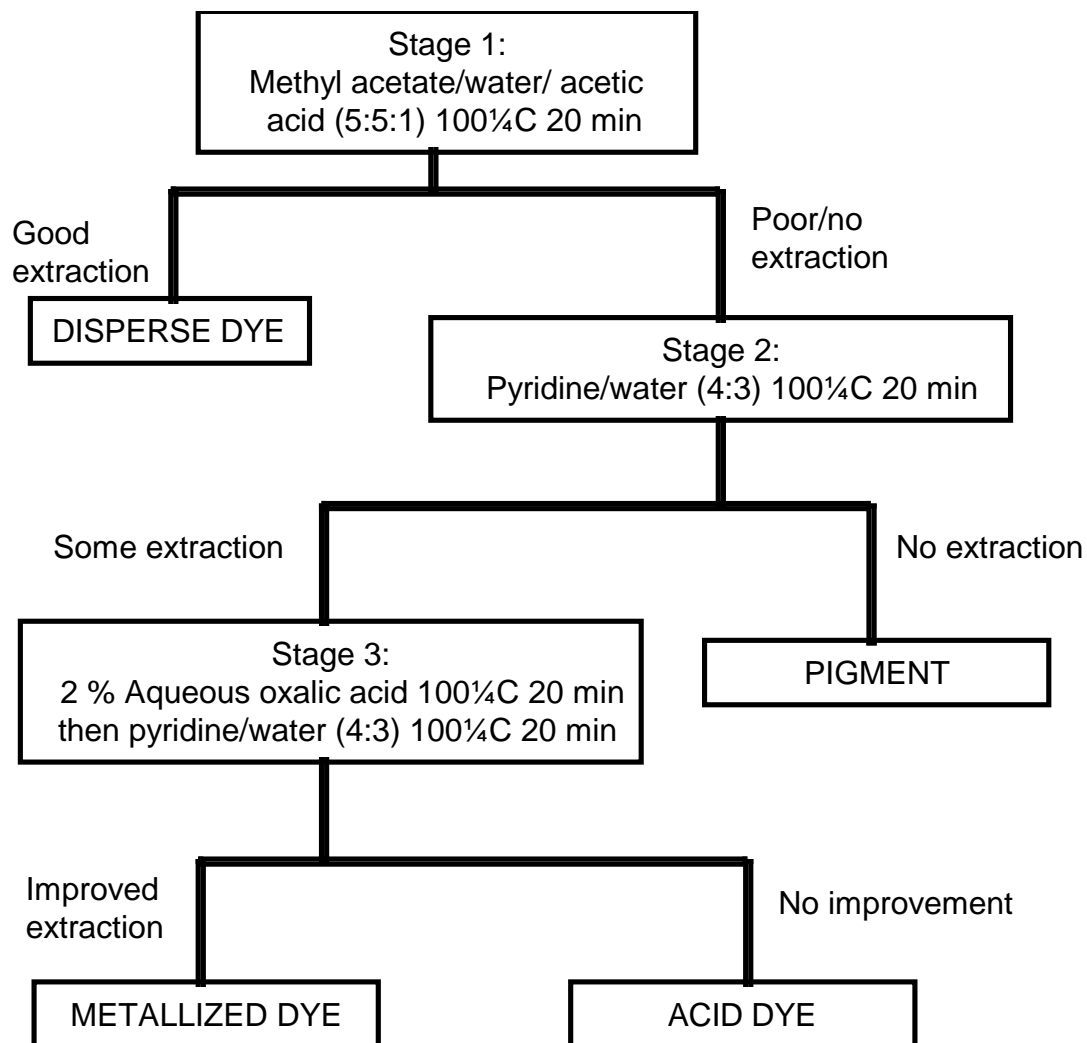


**Figure 11.5** Extraction and classification of dyes from polyamide fibres (Wiggins, 1999)





**Figure 11.6 Extraction and classification of dyes from polyester fibres (Wiggins, 1999)**



**Figure 11.7 Extraction and classification of dyes from polypropylene fibres (Wiggins, 1999)**

Some additional approaches to extraction of reactive dyes from wool and cotton fibres have been suggested. The extracts obtained are not true dye extracts, as the dyes are covalently bound to the fibres.(Wiggins, 1999) The fibre structure needs to be disrupted to release a coloured solution. The procedures are rather more involved than the simple extraction procedure outlined above. For wool, fibres are placed in a glass tube with 3  $\mu\text{L}$  sodium hydroxide solution (see Table 11.2 for details), the tube is sealed and then incubated at 45°C for 24 hours with continuous agitation. This is followed by the addition of 2  $\mu\text{L}$  citric acid, mixing and centrifugation at 7000 rpm for 5 minutes. Cotton fibres are placed in a more concentrated sodium hydroxide solution (5  $\mu\text{L}$ , see Table 11.2 for details) at 0°C for 4 hours. The solution is then discarded and the fibres re-suspended in 5  $\mu\text{L}$  acetic acid for 20 seconds. The resulting solution is again discarded and 3  $\mu\text{L}$  cellulase solution added. The tube is re-sealed and incubated at 45°C for 24 hours with continuous agitation. This is followed by the addition of 3  $\mu\text{L}$  methanol, mixing and centrifugation at 7000 rpm for 5 minutes.(Wiggins, 1999)

**Table 11.2 Extraction and Disruption Solutions for Fibre Dye Analysis**

Solution	Composition and Preparation
Pyridine/water	4:3 v/v, prepare 100 mL and use until exhausted
Formic acid/water	1:1 v/v, prepare 100 mL and used until exhausted
Aqueous oxalic acid	0.2 g in 100 mL water, use immediately and discard excess
Acetic acid	0.5 M acetic acid, prepare 100 mL and use until exhausted
Cellulase	Cellulase ( <i>Penicillium funiculosum</i> ) 1.6 mg/mL in sodium acetate buffer (0.1 M in water adjusted to pH 5 ± 0.2 with glacial acetic acid) prepare 50 mL and discard at end of each week.
Sodium hydroxide for wool	0.75 M in water, prepare 100 mL and use until exhausted or end of one month
Sodium hydroxide for cotton	3.0 M in water, prepare 100 mL and use until exhausted or end of one month

(Wiggins, 1999)

Once classification of the dye has occurred via the schemes described in Figures 11. 2 to 11.7, extraction for TLC analysis can be carried out as outlined in Table 11.3.

**Table 11.3 Choice of Extraction Solutions for Fibre Dye Analysis**

Dye class	Fibre type	Extraction Solution
Acid	Wool, silk, polyamide, protein, polyacrylonitrile, polypropylene	Pyridine/water
Azoic	Cotton, viscose	Pyridine/water
Basic	Polyacrylonitrile, modified acrylic	Formic acid/water
Direct	Polyester, polyamide	Pyridine/water
Disperse	Cotton, viscose	Pyridine/water
	Polyester, polyacrylonitrile, polyamide, polypropylene, acetate, triacetate	Pyridene/water
Metallized	Wool, polypropylene	Aqueous oxalic acid then pyridine/water

(Wiggins, 1999)

### 11.3.2 Separation

After extraction, separation of the coloured components is required and this has generally been achieved through the use of chromatographic techniques. Chromatography is defined by IUPAC as a “physical method of separation in which the components to be separated are distributed between two phases, one of which is stationary (stationary phase) while the other (the mobile phase) moves in a definite direction”.(MacNaught and Wilkinson, 1997) The chromatographic techniques that have been used for forensic fibre dye analysis are thin layer chromatography (TLC)(Beattie et al., 1981b, Home and Dudley, 1981, Laing et al., 1990, Shaw, 1980, Wiggins, 1999, Wiggins et al., 2005) and high-performance liquid chromatography (HPLC).(Griffin and Speers, 1995, Griffin and Speers, 1999, Griffin et al., 1994, Huang et al., 2005, Huang et al.,

2004, Laing et al., 1988, Oxspring et al., 1994, Petrick et al., 2006, Speers et al., 1994, Wheals et al., 1985, Yinon and Saar, 1991) More recently a non-chromatographic separation technique, capillary electrophoresis (CE) has also been proposed.(Oxspring et al., 1994, Robertson, 1999, Siren and Sulkava, 1995, Tetler et al., 1994, Xu et al., 2001)

### *Thin Layer Chromatography (TLC)*

In TLC the stationary phase is present as a thin layer upon an inert rigid support. Izmailov and Schraiber first suggested this approach in the 1930's, but TLC in the form it is recognised today was not established until the 1950's.(Robards et al., 1994) Today there is a wide range of pre-made plates with a variety of different stationary phases available to the scientist. A typical TLC separation involves application of a solution of the sample to be analysed as a discrete spot or smear upon the chromatographic plate. Once the solvent in which the sample was applied has evaporated, the plate is developed by allowing a mobile phase to move by capillary action through the stationary phase, carrying the components contained within the sample with it. These components are retained to different extents by the stationary phase thus leading to separation. The elution characteristics of compounds can be reported as  $R_f$  values, which are a measure of the relative distance travelled by each compound from the origin with respect to the solvent front.

TLC is essentially a variant of liquid chromatography or HPLC, with the mobile phases and stationary phases utilised being common to both. There are some key differences between the two approaches. In TLC, unlike HPLC, there is no need for the sample solvent to be compatible with the mobile phase as it is evaporated off when applying the sample to the plate. Similarly there is no requirement for the mobile phase to be compatible with detection as is the case with HPLC. TLC is an "open bed" method, with retention being observable at all stages, unlike in HPLC where if a component is strongly retained, the only indication will be the lack of a peak. In TLC standards and samples can be run simultaneously on a single plate under identical conditions. A key advantage of TLC is its relative simplicity when compared to other chromatographic techniques. The steps in a TLC analysis have been defined as (Robards et al., 1994):

- (i) selection of a suitable chromatographic stationary phase
- (ii) application of the sample
- (iii) selection of a mobile phase
- (iv) development
- (v) visualisation and detection

This can also be followed by quantification, however this is not generally utilised in forensic fibre dye analysis.(Wiggins, 1999)

There are, however, some disadvantages to TLC. Due to reliance on capillary action for development, flow rate of mobile phase is difficult to control with any precision. Detection limits are also an issue, with HPLC being far better in this

regard. In addition there is a certain amount of manual dexterity required to load (or “spot”) the samples onto the plate and this can introduce some variability.

A range of stationary phases is available for TLC, which can be classified on the basis of their composition and primary mechanism of retention. The most popular phases in common use are silica gel and alumina, the main retention mechanism for both being due to an adsorption process involving affinity of polar and polarisable compounds to the stationary phase.(Robards et al., 1994) Non-polar components are not retained and move further along the TLC plate. Aromatic compounds are readily polarisable; hence this mode of TLC is well suited to the separation of fibre dyes that have extensive aromaticity and many other polarisable functional groups.

The stationary phase is laid down as a thin layer (100 – 2000  $\mu\text{m}$ ) thick upon an inert rigid support, such as glass or aluminium.(Robards et al., 1994) While in earlier times the scientist had to undertake the laborious and time consuming process of preparing these plates from scratch, there are now many commercial sources of pre-made plates. A specific type of plate which has been previously recommended for forensic analysis of dye fibres is aluminium backed silica gel 60F 254, with dimensions of 5 x 7.5 cm available from Merck.(Wiggins, 1999) Prior to use, it has been recommended that these silica plates are either stored in desiccator or heated. This step is to ensure that any water that may be present is driven off, as this will alter the activity of the silica stationary phase.(Wiggins, 1999) The term activity describes the particular properties of the adsorbent, which give rise to retention of a given substance, it is determined by both the chemical structure of the sorbent and any adsorbed species. Adsorbed water has a great effect on both retention, which is decreased with increasing humidity, and also may alter the selectivity of the separation. The efficacy of heating has been questioned as re-adsorption of water occurs extremely rapidly, with a plate becoming significantly re-equilibrated with ambient humidity within 5 minutes of removal from a desiccator or other humidity controlled environment.(Robards et al., 1994) What is clear is that the plates need to be stored and prepared in a controlled and reproducible manner, preferably in a humidity-controlled environment.

Appropriate application of the sample is highly important in obtaining good separations. In principle it is very simple, using a glass capillary or micropipette the dye extract is applied as spot of approximately 2mm in diameter, typically about 1 cm from the bottom edge of the plate.(Wiggins, 1999) To ensure good results there are a number of practical issues that need to be faced. Care needs to be taken not to damage the adsorbent layer or to produce an excessive spot size. The solvent used to load the sample should be able to wet the stationary phase and it should also be volatile so that it can be driven off prior to development of the plate. This process can be accelerated through the application of heat, either applied using a hair dryer or by having the plate rest upon a hot surface. To increase the amount of dye material on the plate, thus providing a more detectable result, repeated application of sample on the initial spot could be carried out. It is recommended that both questioned samples, known samples and standard dye mixtures are run at the same time, with the questioned sample

being bracketed by known samples or standard dyes.(Wiggins, 1999) The applied spots should not be too close to each other, or to the edge of the plate.

There are a number of different approaches to developing TLC plates, with varying levels of complexity. However the simplest, and most widely used approach is the ascending linear method.(Robards et al., 1994) Once the plate is completely dry, it placed in a pool of eluent contained within a covered chamber. This can be as simple as a beaker with a petri dish cover, or alternatively a commercially available development chamber. Prior to use the eluent needs to stand for a few minutes in the covered chamber to allow the chamber to become saturated with eluent vapour.(Robards et al., 1994) The depth of eluent should be such that when the plate is placed in the chamber, the eluent level should be below the applied spots, a distance of at least 0.5 cm has been recommended.(Wiggins, 1999) The eluent will then move up the plate by capillary action, this process takes only a few minutes and separation of the components within the applied dye spots will be observed. Development should be carried out until the eluent has travelled around 2 cm beyond the origin where the spots were applied.(Wiggins, 1999) Any further than this may lead to the separated spots become diffuse, which makes visualisation and interpretation problematic.

The eluents used for TLC of fibre dyes will depend on the class of dye being analysed, Table 11.4 summarise the composition of eluent mixtures and their application to particular dye classes. It has been recommended that a minimum of two eluents should be applied to the analysis of a particular dye extract.(Wiggins, 1999) Issues which need to be considered when deciding whether a particular eluent system is suitable for a dye extract include; separation and sharpness of bands, how far the bands have moved from the origin, how close to the separated bands are to the solvent front and the strength (concentration) of the dye extract from the recovered (questioned) fibres. (Wiggins, 1999)

Interpretation of the developed TLC plates is carried out by comparing the band position and colours of the questioned and control fibre extracts. This can be done under normal laboratory lighting or the use of ultraviolet light. Rf values can be calculated, however they are of limited value when comparing between plates due to subtle differences in development that lead to different retention.

A recovered fibre may be too pale in colour or too short to enable the dye extract to be concentrated enough to obtain a successful TLC. There is no simple way to predict whether a fibre is going to be long enough, analysis of an equivalent control fibre is therefore highly recommended.(Wiggins, 1999) In these circumstances the more sensitive approach of HPLC may yield more successful results.

**Table 11.4 Eluents for TLC Analysis of Extracted Fibre Dyes**

Eluent No.	Solvents (Proportions v/v)*	Fibre type	Dye class
1.	n-butanol, acetone, water, ammonia (5:5:1:2)	Wool or silk Cotton or viscose Polyacrylonitrile Wool	Acid or metallised Direct Basic Reactive
2.	Pyridine, amyl alcohol, 10% ammonia (4:3:3)	Wool or silk	Acid or metallised
3.	n-Butanol, ethanol, ammonia, pyridine, water (8:3:4:4:3)	Cotton or viscose Cotton	Direct Reactive
4.	Methanol, amyl alcohol, water (5:5:2)	Cotton or viscose Cotton	Direct Reactive
5.	Toluene, pyridine (4:1)	Cotton or viscose Polyester	Azoic Disperse
6.	Chloroform, ethyl acetate, ethanol (7:2:1)**	Polyester	Disperse
7.	n-Hexane, ethyl acetate, acetone (5:4:1)	Polyester	Disperse
8.	Toluene, methanol, acetone (20:2:1)	Polyester	Disperse
9.	n-Butanol, acetic acid, water (2:1:5)***	Polyamide	Acid
10.	n-Butanol, ethanol, ammonia, pyridine (4:1:3:2)	Polyamide	Acid
11.	Chloroform, butanone, acetic acid, formic acid** (8:6:1:1)	Polyacrylonitrile	Basic
12.	n-Butanol, acetic acid, water (4:1:5)***	Polyacrylonitrile	Basic
13.	Propan-1-ol, methanol, water, ammonia (6:3:1:4)	Wool	Reactive
14.	n-Butanol, ethanol, ammonia, pyridine, water (8:3:4:4:6)	Cotton	Reactive
15.	n-Butanol, ethanol, ammonia, pyridine, water (6:3:2:6:6)	Cotton	Reactive

\*Ethanol used is 99 %, ammonia is 0.880 SG unless other wise stated, eluents discarded weekly except for \*\* which should be discarded daily.

\*\*\* These eluent combinations form an upper and lower phase, use upper phase as eluent (Wiggins, 1999)

**Table 11.5 Standard Dye Mixtures for TLC Analysis of Fibre Dyes**

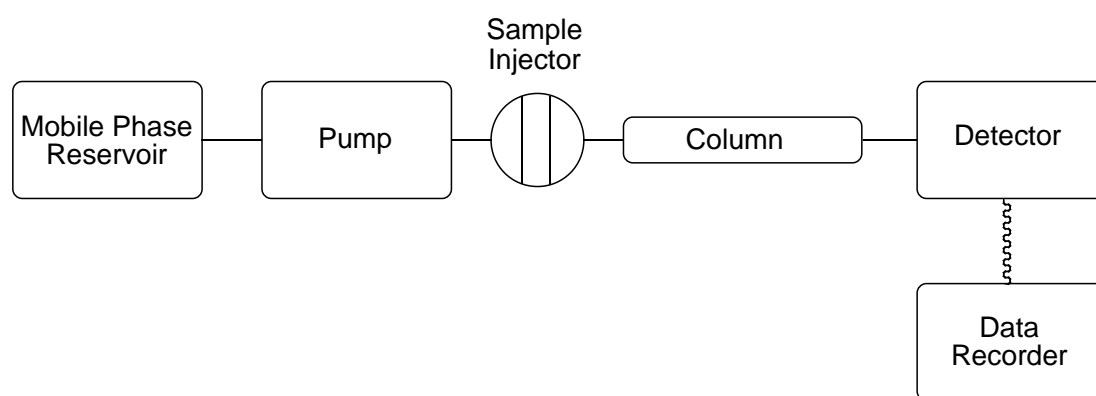
	Standard Dye Mixture*	Eluent No.
A	Solway green G (CI acid green 25) Solway blue RNS (CI acid blue 47) Naphthalene fast orange (CI acid orange 10)	1, 2, 3, 4, 9, 10, 12, 13, 14, 15
B	Superacet fast orange (CI disperse orange 3) Superacet fast violet B (CI disperse violet 8) Superacet scarlet 2G (CI disperse orange 1)	5, 7, 8
C	Superacet fast orange (CI disperse orange 3) Superacet fast violet B (CI disperse violet 8)	6
D	Solway green G (CI acid green 25) Superacet fast orange (CI disperse orange 3) Superacet fast violet B (CI disperse violet 8)	11

\*Approximately 5 mg of each dye made up to a final volume of 25 mL with pyridine/water 4:3. Use until exhausted.

(Wiggins, 1999)

## High Performance Liquid Chromatography (HPLC)

Since its introduction in the late 1960's high performance liquid chromatography (HPLC) has become perhaps the most widely used analytical separation technique in use today. In HPLC the stationary phase, typically particles in the range 3 – 5  $\mu\text{m}$  are contained within a column with dimensions of 3 to 25 cm in length and 3 to 5 mm internal diameter. The mobile phase is pumped through the stationary phase at high pressure (up to 6000 psi) with flow rates of 0.1 to 10 mL/min. Samples are introduced into the system before the separation column using a variety of injection devices which can be manual or automated. A number of different approaches can be used to detect the eluting analytes; the most common is ultraviolet-visible absorbance spectrophotometry however mass spectrometry has also been used in the analysis of fibre dyes. The resulting separation is recorded as a graph, formerly on a chart recorder but now electronically using a computer, which is referred to as a chromatogram. A schematic of a typical HPLC system is presented in Fig 11.8.



**Figure 11.8 Schematic Diagram of the Components of an HPLC System**

There are a number of different forms of HPLC depending on the type of retention mechanism involved. By far the most common is partition chromatography, which can be further divided into reversed phase chromatography and normal phase chromatography. The stationary phase for partition chromatography is chemically bonded to silica particles. For reversed phase chromatography the bonded phase is relatively non-polar with polar compounds eluting first from the column, while for normal phase chromatography, which utilises relatively polar stationary phases, non-polar compounds are the first to elute.

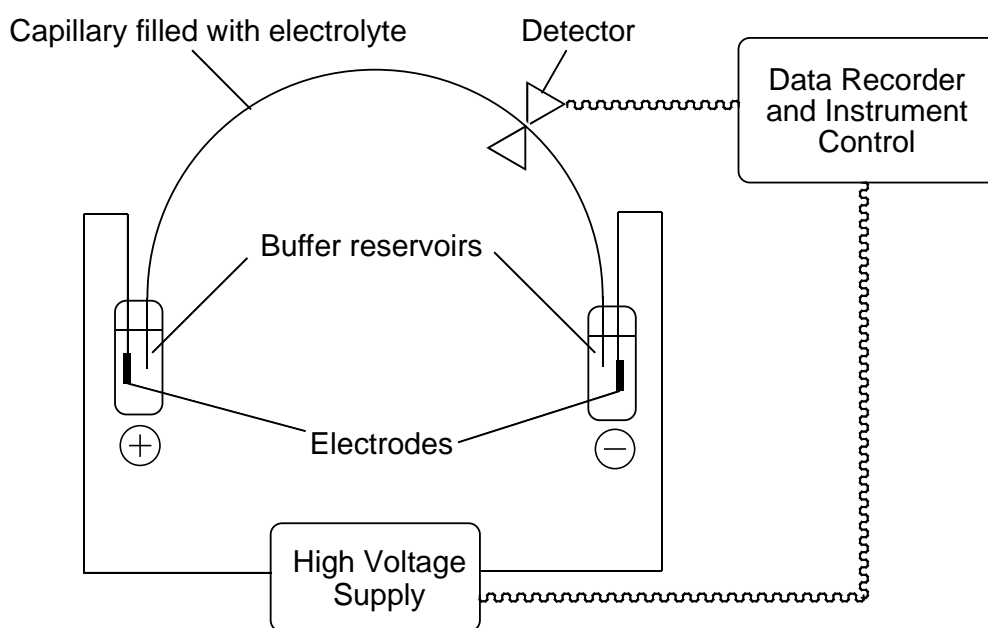
HPLC is an extremely powerful separation technique that is widely used in all areas of analytical science. A wide range of stationary phases is available to the analyst in combination with an almost limitless range of mobile phase compositions. It is this flexibility that also increases the complexity of the development process for a new analytical separation. HPLC also has high initial set-up costs and significant running costs when compared with TLC. As samples are introduced in solution into an HPLC system, another issue is the potential incompatibility between the extraction solvent and the separation conditions.(Griffin and Speers, 1999)



HPLC however has the advantages of far greater efficiency separations, being able to resolve the components of very complex mixtures, and greater sensitivity. This latter is a particular advantage when analysing extremely small samples of material. The powerful combination of HPLC coupled with mass spectrometry has been applied to forensic fibre dye analysis.(Huang et al., 2005, Huang et al., 2004, Petrick et al., 2006, Yinon and Saar, 1991) This allows the determination of molecular structure information on eluted bands and thus provides an extra dimension of information.

### *Capillary Electrophoresis (CE)*

The term capillary electrophoresis (CE) is used to describe a group of techniques where separation of the components of a chemical mixture occurs in a narrow bore capillary under the influence of an electric field. In its simplest form separations in CE are based upon the differential migration of charged species through a fused silica capillary filled with the background electrolyte. Detection is typically by ultraviolet-visible absorbance spectrophotometry, resulting in graph, which looks similar to a chromatographic separation and is often referred to as an electropherogram. A schematic of typical CE instrument is presented in Fig 11.9. Dedicated capillary electrophoresis instruments, which automate many of the processes in carrying out an analysis, are available. For neutral species separations are made possible by addition of surfactants to the background electrolyte above the critical micelle concentration. This leads to the formation of micelles, which act as a “pseudo-stationary” phase, separation being achieved by interaction between the analytes and the micelles. This hybrid of chromatography and CE is termed micellar electrokinetic chromatography (MEKC).



**Figure 11.9 Schematic Diagram of a CE System**

Highly efficient, rapid separations are possible and CE in its various modes is a well-established analytical technique with over 30,000 references to date in a diverse range of application areas. Forensic application of CE was first demonstrated by Weinberger and Lurie and since then has been the subject of a number of reviews and book chapters. What makes CE so attractive for forensic analysis is its exceptional separation power coupled with rapid analysis, minimal sample preparation low reagent usage and waste production. That being said, there has been little use of this technique for the forensic analysis of fibre dyes, with only a few applications reported in the literature.(Oxspring et al., 1994, Robertson, 1999, Siren and Sulkava, 1995, Tetler et al., 1994, Xu et al., 2001) In a similar fashion to HPLC there is the issue of compatibility between the extraction solvent and the separation conditions. Robertson in an early report of the application of CE to the separation of dyes also noted issues with reproducibility and dyes becoming trapped in the capillary.(Robertson, 1999) Nevertheless CE has tremendous potential due to its unrivalled separating power and this area is worthy of further research.

#### **11.4 Conclusions**

Despite the rise of more modern instrumental methods such as HPLC and CE, TLC still has a key role to play in the forensic analysis of dyes. Its simplicity and significant body of knowledge concerning the separation of dyes by this technique by ensure that it remains a key tool. HPLC and CE will also have a place, particularly where sensitivity is an issue. However more research is required, particularly with the latter named technique. One area, which appears not to have had much attention in the published literature over the last decade, is extraction of dyes from fibres. Many of the solvents used in the extraction schemes described earlier in this chapter are hazardous and it would be advantageous to replace them with safer alternatives. Approaches to automating the process would also be an aid in terms of increasing throughput, reducing exposure to hazardous solvents and releasing personnel for other less onerous duties. There are indications that work is commencing in this area ; however there as not been any publications on this subject to date.

#### **11.5 Sources of further information and advice**

A good overview of the basics of chromatography including TLC and HPLC can be found in SKOOG, D.A., HOLLER, F.J. & CROUCH, S.R (2007) Principles of Instrumental Analysis, 6<sup>th</sup> Edition, Belmont, Thomson Brooks/Cole. The same volume also provides a review of CE. A more in depth study of can be found in ROBARDS, K., HADDAD, P. R. & JACKSON, P. E. (1994) Principles and Practice of Modern Chromatographic Methods, London, Academic Press.

Information on dyes and their application can be found in GREGORY, P. (2000) Dyes and Dye Intermediates. Kirk-Othmer Encyclopedia of Chemical Technology. John Wiley & Son. The Colour Index can be found on-line at [www.colour-index.org](http://www.colour-index.org).

A key resource in for forensic dye analysis by TLC, with particular reference to the extraction schemes developed by the Forensic Science Service in the United Kingdom is WIGGINS, K. G. (1999) Thin Layer Chromatographic Analysis of Fibre Dyes. IN ROBERTSON, J. & GRIEVE, M. (Eds.) *Forensic Examination of Fibres*. 2 ed. London, Taylor and Francis.

## 11.6 Acknowledgments

The author would like to than Dr Susan Bennett (New South Wales Forensic Services Group) for guidance in the early stages of preparation of this chapter and Emma Patton (Curtin University of Technology) for useful comments on the draft manuscript.

## 11.7 References

- BEATTIE, B., ROBERTS, H. & DUDLEY, R. J. (1981a) The extraction and classification of dyes from cellulose acetate fibers. *Journal of the Forensic Science Society*, 21, 233-7.
- BEATTIE, I. B., DUDLEY, R. J. & SMALLDON, K. W. (1979) The extraction and classification of dyes on single nylon, polyacrylonitrile and polyester fibers. *Journal of the Society of Dyers and Colourists*, 95, 295-302.
- BEATTIE, I. B., ROBERTS, H. L. & DUDLEY, R. J. (1981b) Thin-layer chromatography of dyes extracted from polyester, nylon and poly(acrylonitrile) fibers. *Forensic Science International*, 17, 57-69.
- CHENG, J., WANOGHO, S., WATSON, N. D. & CADDY, B. (1991) The extraction and classification of dyes from cotton fibers using different solvent systems. *Journal of the Forensic Science Society*, 31, 31-40.
- CONNELLY, R. (1997) Colorant formation for the textile industry. *Color Technology in the Textile Industry*. Research Triangle Park, North Carolina, American Association of Textile Chemists and Colorists.
- GARFIELD, S. (2000) *Mauve*, London, Faber and Faber.
- GREGORY, P. (2000) Dyes and Dye Intermediates. *Kirk-Othmer Encyclopedia of Chemical Technology*. John Wiley & Sons.
- GRIFFIN, R. M. E. & SPEERS, S. J. (1995) Use of tapered vials for in situ extraction of fiber dyes for analysis by HPLC. *Science & Justice*, 35, 203-5.
- GRIFFIN, R. M. E. & SPEERS, S. J. (1999) Other Methods of Colour Analysis: High Performance Liquid Chromatography. IN ROBERTSON, J. & GRIEVE, M. (Eds.) *Forensic Examination of Fibres*. London, Taylor and Francis.
- GRIFFIN, R. M. E., SPEERS, S. J., ELLIOTT, L., TODD, N., SOGOMO, W. & KEE, T. G. (1994) An improved high-performance liquid chromatography system for the analysis of basic dyes in forensic casework. *Journal of Chromatography, A*, 674, 271-80.
- HARTSHORNE, A. W. & LAING, D. K. (1984) The dye classification and discrimination of colored polypropylene fibers. *Forensic Science International*, 25, 133-41.
- HOME, J. M. & DUDLEY, R. J. (1981) Thin-layer chromatography of dyes extracted from cellulosic fibers. *Forensic Science International*, 17, 71-8.
- HUANG, M., RUSSO, R., FOOKES, B. G. & SIGMAN, M. E. (2005) Analysis of fiber dyes by liquid chromatography mass spectrometry (LC-MS) with electrospray ionization: Discriminating between dyes with indistinguishable UV-visible absorption spectra. *Journal of Forensic Sciences*, 50, 526-534.
- HUANG, M., YINON, J. & SIGMAN, M. E. (2004) Forensic identification of dyes extracted from textile fibers by liquid chromatography mass spectrometry (LC-MS). *Journal of Forensic Sciences*, 49, 238-249.
- LAING, D. K., DUDLEY, R. J., HARTSHORNE, A. W., HOME, J. M., RICKARD, R. A. & BENNETT, D. C. (1991) The extraction and classification of dyes from cotton and viscose fibers. *Forensic Science International*, 50, 23-35.

LAING, D. K., GILL, R., BLACKLAWS, C. & BICKLEY, H. M. (1988) Characterization of acid dyes in forensic fiber analysis by high-performance liquid chromatography using narrow-bore columns and diode array detection. *Journal of Chromatography*, 442, 187-208.

LAING, D. K., HARTSHORNE, A. W. & BENNETT, D. C. (1990) Thin layer chromatography of azoic dyes extracted from cotton fibers. *Journal of the Forensic Science Society*, 30, 309-15.

MACNAUGHT, A. D. & WILKINSON, A. (1997) *IUPAC Compendium of Chemical Terminology*, Oxford, Blackwell Science.

MACRAE, R. & SMALLDON, K. W. (1979) The extraction of dyestuffs from single wool fibers. *Journal of Forensic Sciences*, 24, 109-16.

OXSPRING, D. A., O'KANE, E., MARCHANT, R. & SMYTH, W. F. (1994) The separation and determination of reactive textile dyes by capillary electrophoresis and high performance liquid chromatography. *Analytical Methods & Instrumentation*, 1, 196-202.

PETRICK, L. M., WILSON, T. A. & FAWCETT, W. R. (2006) High-performance liquid chromatography-ultraviolet-visible spectroscopy-electrospray ionization mass spectrometry method for acrylic and polyester forensic fiber dye analysis. *Journal of Forensic Sciences*, 51, 771-779.

RESUA, R. (1980) A semi-micro technique for the extraction and comparison of dyes in textile fibers. *Journal of Forensic Sciences*, 25, 168-73.

ROBARDS, K., HADDAD, P. R. & JACKSON, P. E. (1994) *Principles and Practice of Modern Chromatographic Methods*, London, Academic Press.

ROBERTSON, J. (1999) Other Methods of Colour Analysis: Capillary Electrophoresis. IN ROBERTSON, J. & GRIEVE, M. (Eds.) *Forensic Examination of Fibres*. London, Taylor and Francis.

SHAW, I. C. (1980) Micro-scale thin-layer chromatographic method for the comparison of dyes stripped from wool fibers. *Analyst (Cambridge, United Kingdom)*, 105, 729-30.

SIREN, H. & SULKAVA, R. (1995) Determination of black dyes from cotton and wool fibers by capillary zone electrophoresis with UV detection: application of marker technique. *Journal of Chromatography, A*, 717, 149-55.

SPEERS, S. J., LITTLE, B. H. & ROY, M. (1994) Separation of acid, basic and dispersed dyes by a single-gradient elution reversed-phase high-performance liquid chromatography system. *Journal of Chromatography, A*, 674, 263-70.

TETLER, L. W., COOPER, P. A. & CARR, C. M. (1994) The application of capillary electrophoresis/mass spectrometry using negative-ion electrospray ionization to areas of importance in the textile industry. *Rapid Communications in Mass Spectrometry*, 8, 179-82.

WEST, J. C. (1981) Extraction and analysis of disperse dyes on polyester textiles. *Journal of Chromatography*, 208, 47-54.

WHEALS, B. B., WHITE, P. C. & PATERSON, M. D. (1985) High-performance liquid chromatographic method utilizing single or multi-wavelength detection for the comparison of disperse dyes extracted from polyester fibers. *Journal of Chromatography*, 350, 205-15.

WIGGINS, K. G. (1999) Thin Layer Chromatographic Analysis of Fibre Dyes. IN ROBERTSON, J. & GRIEVE, M. (Eds.) *Forensic Examination of Fibres*. 2 ed. London, Taylor and Francis.

WIGGINS, K. G., COOK, R. & TURNER, Y. J. (1987) Dye Batch Variation in Textile Fibres. *Journal of Forensic Sciences*, 33, 998-1007.

WIGGINS, K. G., HOLNESS, J.-A. & MARCH, B. M. (2005) The importance of thin layer chromatography and UV microspectrophotometry in the analysis of reactive dyes released from wool and cotton fibers. *Journal of Forensic Sciences*, 50, 364-368.

[WWW.COLOUR-INDEX.ORG](http://WWW.COLOUR-INDEX.ORG) (2007) Colour Index International. Society of Dyers and Colourists, American Association of Textile Chemists and Colorists.

XU, X., LEIJENHORST, H., VAN DEN HOVEN, P., DE KOEIJER, J. A. & LOGTENBERG, H. (2001) Analysis of single textile fibres by sample-induced isotachopheresis - micellar electrokinetic capillary chromatography. *Science & Justice*, 41, 93-105.

YINON, J. & SAAR, J. (1991) Analysis of dyes extracted from textile fibers by thermospray high-performance liquid chromatography-mass spectrometry. *Journal of Chromatography*, 586, 73-84.