

Application of UPFC to Improve the FRT Capability of Wind Turbine Generator

Yasser M. Alharbi
Ministry of Higher Education, Saudi Arabia
King Abdullah scholarship Program
y.alharbi77@gmail.com

A. M. Shiddiq Yunus
Mechanical Eng. Department, Energy Conv. Study Prog.
State Polytechnic of Ujung Pandang
South Sulawesi, Indonesia
shiddiq_96@yahoo.com.sg

Ahmed Abu-Siada
Electrical and Computer Eng. Department
Curtin University
Perth, Western Australia
a.abusiada@curtin.edu.au

Abstract—Variable speed wind turbine generators installation has been significantly increased worldwide in the last few years. Faults at the grid side may call for the disconnection of the wind turbine from the grid as under such events, wind turbine generator (WTG) may not comply with the recent developed grid codes for wind energy conversion systems (WECS). In this paper, a unified power flow controller (UPFC) is applied to improve the fault ride through (FRT) capability of doubly fed induction generator (DFIG)-based WECS during voltage swell and voltage sag at the grid side. Simulation is carried out using MATLAB/Simulink software. Results show that UPFC can effectively improve the FRT capability of DFIG-based WECS and hence maintaining wind turbine connection to the grid during certain levels of voltage fluctuation at the grid side.

Index Terms— HVRT, LVRT, UPFC, DFIG, WTG

I. INTRODUCTION

RENEWABLE energy sources have been recently given a significant concern worldwide as they generate electricity from infinite and clean natural resources [1, 2]. Wind energy is one of the most efficient and promising renewable energy resources in the world which is continuously growing with the increase of electrical power demand and the decrease in conventional electricity generation resources [3]. In the year 2012, the growth rate in wind power generation worldwide was 28% and by the year 2015 the global wind power capacity is expected to be 600 000 MW which is expected to increase to 150 000 MW by the year 2020 [4]. In the early stages of using wind turbine generators (WTG), it was allowed to disconnect the WTG from the grid during the event of grid

disturbances to avoid wind turbine damages. Due to the significant increase in WTGs and the global trend to establish reliable smart grids, the transmission system operators (TSOs) require the connection of WTGs with the grid to be maintained during certain level of faults to provide support to the grid during fault conditions. Therefore, grid codes have been established in many countries to comply with the new requirements. Since voltage fluctuation is a common power quality problem in power systems, most of studies are focused on the performance of WTGs during voltage sag [5-7]. Although it is a less power quality problem, voltage swell may also lead to the disconnection of WTGs from the grid. Voltage swell is mainly caused by switching off a large load, energizing a capacitor bank and voltage increase in un-faulted phases during a single line-to-ground fault and is defined as an increase in voltage level in a range of 1.1 pu to 1.8 pu for a duration of 0.5 cycle to 1 minute [8]. On the other hand, voltage sag is defined as a decrease in voltage level within a range of 0.9 pu to 0.2 pu of the nominal steady state level for a duration of 0.5 cycle to 1 minute [8]. There are many international codes related to the fault ride through (FRT) capability of WTGs. Among these codes, this paper focuses on the FRT grid codes for Spain and the US shown in Fig. 1.

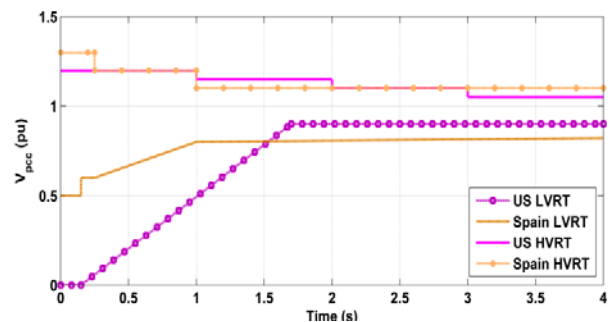

Fig. 1. FRT grid codes of Spain and US

Y. M. Alharbi is with king Abdullah scholarship program (e-mail: eng.yh2@gmail.com).

A. M. Shiddiq Yunus is with the Departement of Mechanical Engineering, State Polytechnic of Ujungpandang, Indonesia (email Shiddiq@poliupg.ac.id).

A. Abu-Siada is with the Department of Electrical and Computer Engineering, Curtin University, Perth, WA 6845 Australia (e-mail: a.abusiada@curtin.edu.au).

Fig. 1 shows the Spain and US grid codes for FRT capability of wind turbine generators. The allowed voltage swell at the point of common coupling (PCC) of the US grid code is 1.2 pu that lasts for a duration of 1s from the fault occurrence. After that the HVRT profile decreases by 0.05 pu every 1s during the following 3s after which the voltage at the PCC has to be maintained within a safety margin of 0.05 pu from the nominal value [9]. On the other hand, the maximum voltage swell at the PCC for Spain grid code at the instant of fault occurrence is 1.3 pu which remains for 0.25s after which it decreases by 0.1 pu that lasts for 1 s. Then the voltage level at the PCC has to be maintained within a safety margin of 0.1 pu above the nominal value [9].

The allowed voltage sag at the PCC of US grid code is 0 pu that lasts for a duration of 0.15s from the occurrence of the fault after which the LVRT profile increases linearly during the following 1.5s to 0.9 pu at which the voltage level is maintained [9]. On the other hand, the minimum acceptable voltages sag at the PCC for Spain grid code at the instant of fault occurrence is 0.5 pu which remains for 0.15s after which it increases to 0.6 pu that lasts for 0.1s. Then LVRT profile ramps to 0.8 pu during the next 0.75s and remains at this level for 3s [9]. WTGs are to be disconnected from the grid in case of voltage levels at the PCC fall outside the area bounded by the LVRT and HVRT margins of the US and Spain grid codes. Flexible AC transmission system (FACTS) devices have been used to maintain the WTGs penetration to the electricity grid during fault conditions [10-12]. This paper investigates the application of unified power flow controller (UPFC) to improve the wind turbine FRT capability in compliance with Spain and US grid codes. To examine the improvement in system performance using UPFC, simulation results of the studied system with and without the connection of the proposed UPFC controller are presented.

II. SYSTEM UNDER STUDY

Fig. 2 shows the system under study, which consists of six 1.5MW DFIG connected to a grid that is simulated as an ideal 3-phase voltage source of constant voltage and frequency through 25 km transmission line and two transformers. The UPFC is connected to the PCC bus to increase the WTG damping and to provide support to the system during fault conditions.

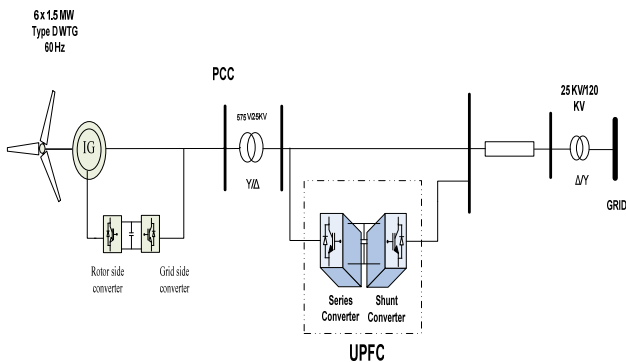

Fig. 2. System under study

The DFIG stator windings are connected directly to the grid through a coupling transformer while the rotor is fed through

two back-to-back voltage source converters linked together by a DC-link capacitor. During normal operation, the reactive power produced by the wind turbines is regulated at 0 Mvar to achieve unity power factor operation. For an average wind speed of 14 m/s, which is used in this study, the turbine output active power is 1.0 pu and the generator speed is 1.0 pu. The UPFC is used to improve the FRT of the WTGs, by controlling the active and reactive power at the bus it is connected to [13].

III. UNIFIED POWER FLOW CONTROLLER

With the enormous global growth in electrical power demand, there has been a challenge to deliver the required electrical power considering the quality, sustainability and reliability of the delivered power. To achieve this goal, it is essential to control the existing transmission systems for efficient utilization and to avoid new costly installations [14].

FACTS technology play an important role in improving the utilization of the existing power system as it can provide technical solutions to improve the power system performance [15]. As a FACTS device, unified power flow controller allows power systems to be more flexible by using high-speed response and decoupled active and reactive power compensations and by installing UPFC at particular locations of the transmission system, the power dispatch can be increased up to the power rating of generators, transformers and thermal limits of line conductors, by increasing the stability margin. Shunt and series converters of the UPFC can control both active and reactive powers in four quadrants smoothly, rapidly and independently [16].

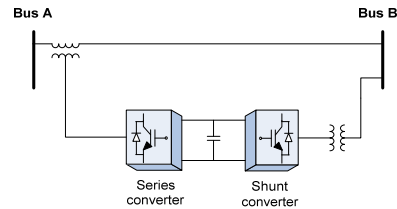

Fig. 3. UPFC configuration

Fig.3 shows a typical configuration of the UPFC where the shunt converter regulates the voltage at the ac bus by maintaining the voltage across the DC link. On the other side, the series converter regulates the AC system active and reactive power by regulating the voltage with respect to line current [16, 17].

Figs. 4 and 5 show the proposed controller for the UPFC series and shunt converters respectively. Clarke-Park transformation is used to convert the a-b-c quantities for the voltage at the PCC along with the transmission line current to the d-q reference frame.

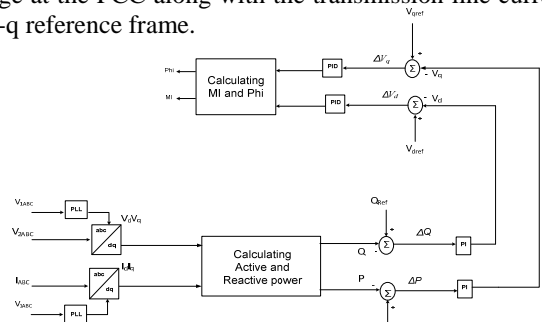

Fig. 4. Control system of the series converter

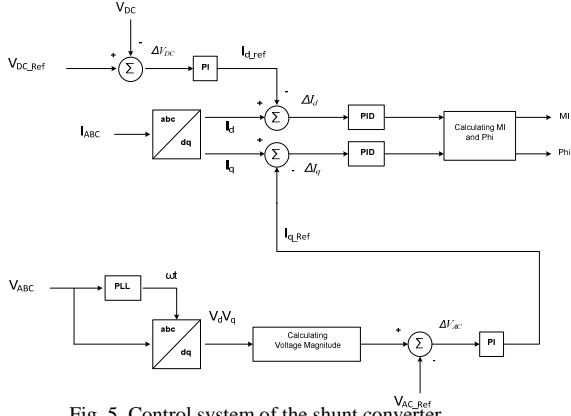

Fig. 5. Control system of the shunt converter

Fig. 4 shows that the active power P and reactive power Q are used to calculate respectively V_q and V_d while Fig. 5 shows that the reactive power can be controlled by the control of the current that is in quadrature with the voltage (I_q) While the current in phase with voltage (I_d) regulates the active power [8].

IV. SIMULATION RESULTS

To show the robustness of the proposed UPFC controller, voltage swell and voltage sag at the grid side are simulated with and without the connection of the UPFC controller as elaborated below.

A. Voltage Swell

Two scenarios are assumed; (i) a voltage swell is simulated at 30s at the PCC and is assumed to last for a duration of 5 cycles on 50 Hz basis.(ii) A voltage swell is assumed to take place at the PCC at $t= 30s$ and lasts for a duration of 0.3s,

The PCC voltage profile for the first scenario compared with the US HVRT grid code as shown in Fig. 6. Without the connection of UPFC, voltage swell at the PCC violates the safety margin of HVRT of the US grid code and therefore the WTGs have to be disconnected from the grid. However, when the UPFC is connected to the system, voltage swell can be maintained within the safety margins specified by the US grid codes as can be shown in Fig.7 and therefore, the WTGs connection can be maintained to support the grid during the fault

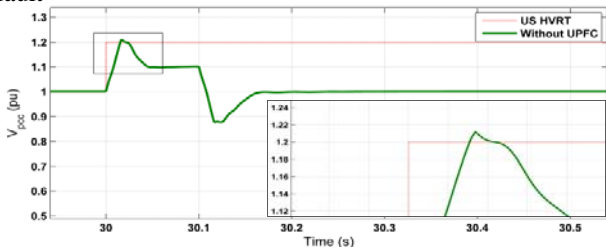

Fig. 6. DFIG compliance with US HVRT without UPFC

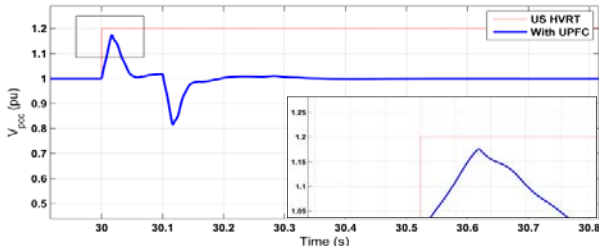

Fig. 7. DFIG compliance with US HVRT with UPFC

The second scenario is compared with the HVRT of Spain grid code is shown in Fig. 8. As can be shown in the figure, the voltage at the PCC violates Spain HVRT level, which calls for the disconnection of the wind turbine from the grid to avoid any possible damages to the WTG. By connecting the UPFC to the PCC bus, the amount of voltage drop at the PCC bus is corrected to reach a safety margin of the Spain grid requirement as shown in Fig. 9 and therefore maintaining the connection of the wind turbine.

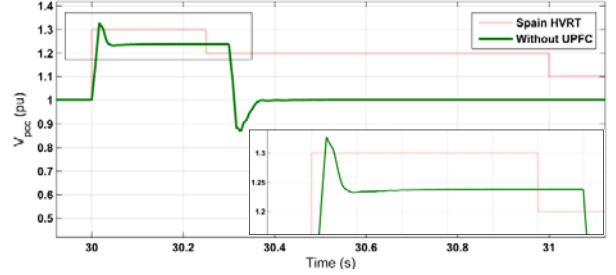

Fig. 8. DFIG compliance with Spain HVRT without UPFC

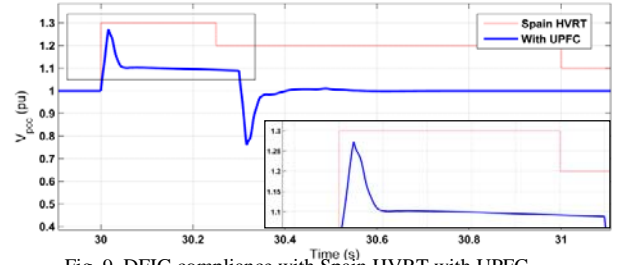

Fig. 9. DFIG compliance with Spain HVRT with UPFC

B. Voltage Sag

Simulation is carried out with a fault at the grid side that causes voltage sag at the PCC bus at $t= 13s$ for duration of 0.7s. The voltage performance at the point of common coupling is investigated during the fault without and with the connection of the UPFC to the PCC bus. Fig. 10 shows that the grid fault causes the voltage at the PCC to decrease to a level lower than 0.5pu. Referring to the Spain LVRT grid code the WTGs are to be disconnected from the grid as this violates its lowest permissible limit as shown in Fig. 10. However, by connecting the UPFC to the grid at the PCC bus, the amount of voltage sag reaches a safety margin of the Spain grid requirement as can be shown in Fig. 11 and hence avoiding the disconnection of WTG.

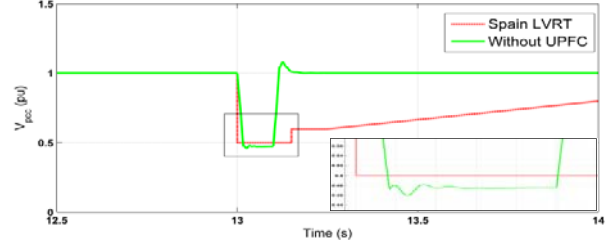

Fig. 10 DFIG compliance with Spain LVRT without UPFC

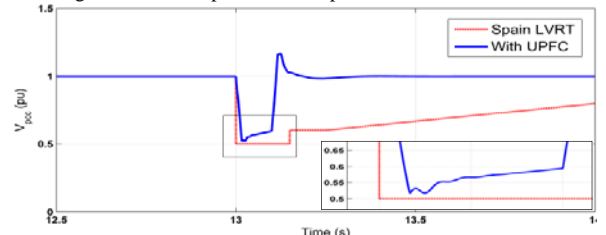

Fig. 11 DFIG compliance with Spain LVRT with UPFC

If the US grid code is applied, without UPFC, voltage sag at the PCC violates the safety margin of LVRT grid code as shown in Fig. 12. When the UPFC is connected to the system, voltage sag can be maintained at a safe level and the WTGs connection to the grid can be maintained during the fault as can be shown in Fig. 13.

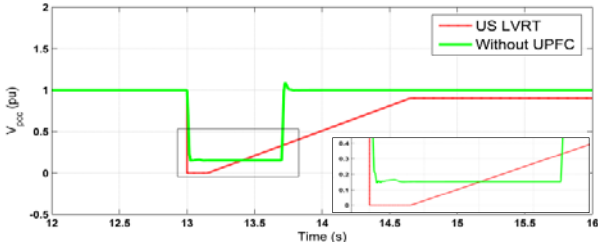

Fig. 12. DFIG compliance with US LVRT without UPFC

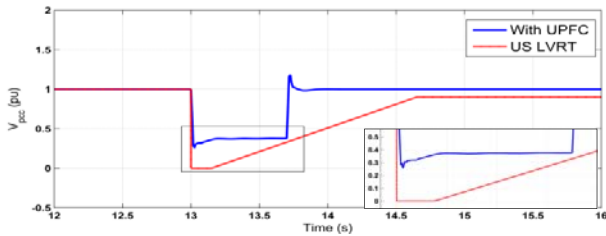

Fig. 13. DFIG compliance with US LVRT with UPFC

Fig. 14 shows the voltage across the DC-link capacitor of the WTG (V_{DC}) with and without the connection of the UPFC. With the UPFC connected to the system, the overshooting and settling time are substantially reduced compared to the system without the connection of the UPFC.

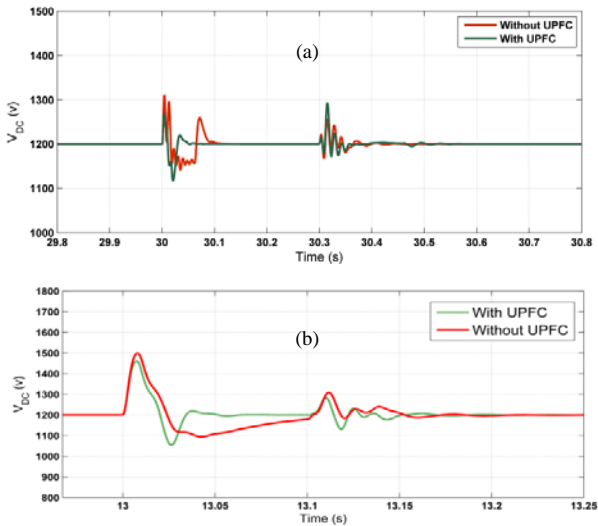

Fig. 14. V_{DC} waveform (a) voltage swell, (b) voltage sag

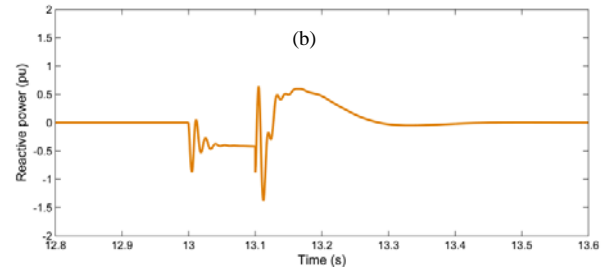
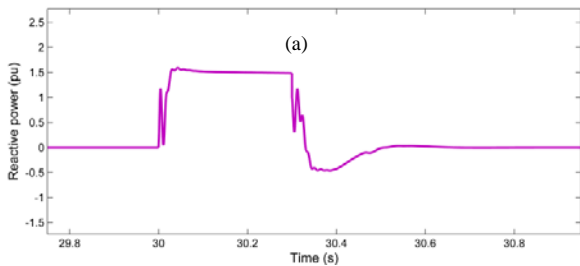

Fig. 15. Reactive power response of UPFC (a) voltage swell, (b) voltage sag

The performance of the UPFC during fault can be examined in Fig. 15. When voltage swell or sag at the PCC is applied, the UPFC controller acts to instantly exchange reactive power with the AC system (delivering in case of voltage sag and absorbing in case of voltage swell) to regulate the voltage at

the PCC within a safety level. It worth to notice that during normal operating conditions, there is no reactive power exchange and the reactive power is maintained at zero level to achieve unity power factor operation for the WTG. The direct and quadrature currents response of the UPFC during the fault are shown in Fig. 16. At normal operating conditions both currents are set to zero level there will be no power transfer between the UPFC and the system. Upon fault occurrence, I_d and I_q levels change accordingly to provide reactive power support to the system during the fault. After fault clearance, both currents return to zero level.

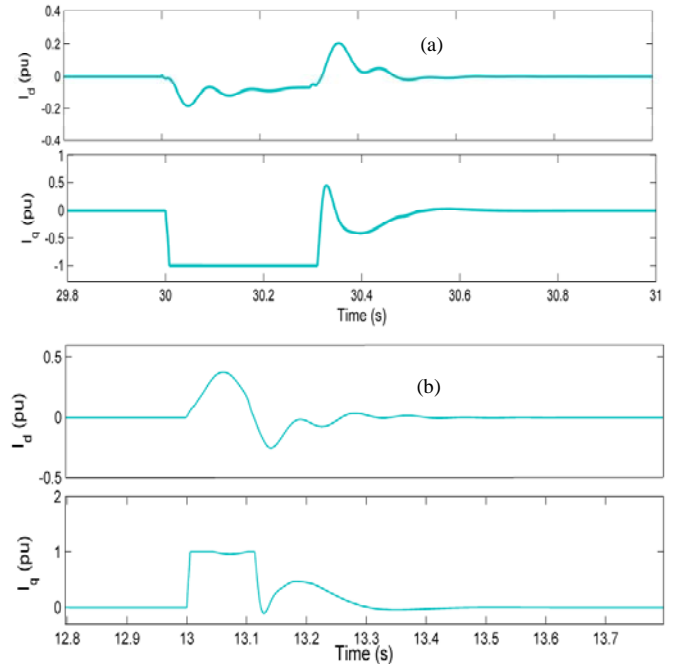

Fig.16. Shunt converter d-q current during (a) voltage swell (b) voltage sag

V. CONCLUSION

This paper investigates the application of UPFC to enhance the FRT of wind energy conversion system to comply with the grid codes of Spain and US. Results show that, without UPFC, WTGs must be disconnected from the grid during voltage swell or voltage sag event to avoid the turbines from being damaged, as the voltage at the PCC will violate the safety

margin requirements of both studied grid codes. The proposed controller for the UPFC can significantly improve the FRT capability of the WTGs and hence their connection to the grid can be maintained to support the grid during fault conditions and to guarantee the continuity its power delivery to the grid.

Appendix

PARAMETERS OF DFIG

Rated Power	6-@1.5MW
Stator Voltage	575 V
Frequency	60 Hz
R_s	1.2pu
V_{DC}	1200 V

ACKNOWLEDGMENT

The first author would like to thank the Higher Education Ministry of Saudi Arabia and King Abdullah scholarship program for providing him with a PhD scholarship at Curtin University, Australia

REFERENCES

- [1] S. Mathew, "Wind energy conversion systems," in *Wind Energy*, ed: Springer Berlin Heidelberg, 2006, pp. 89-143.
- [2] S. Mathew, "Wind energy and environment," in *Wind Energy*, ed: Springer Berlin Heidelberg, 2006, pp. 179-207.
- [3] S. M. Muyeen, *et al.*, "Introduction," in *Stability Augmentation of a Grid-connected Wind Farm*, ed: Springer London, 2009, pp. 1-22.
- [4] "www.wwindea.org/"
- [5] M. M. Kyaw and V. K. Ramachandaramurthy, "Fault ride through and voltage regulation for grid connected wind turbine," *Renewable Energy*, vol. 36, pp. 206-215, 2011.
- [6] A. M. Shiddiq Yunus, *et al.*, "Effect of STATCOM on the low-voltage-ride-through capability of Type-D wind turbine generator," in *Innovative Smart Grid Technologies Asia (ISGT), 2011 IEEE PES*, 2011, pp. 1-5.
- [7] A. M. S. Yunus, *et al.*, "Improvement of LVRT capability of variable speed wind turbine generators using SMES unit," in *Innovative Smart Grid Technologies Asia (ISGT), 2011 IEEE PES*, 2011, pp. 1-7.
- [8] E. F. Fuchs and M. A. S. Masoum, "Power Quality in Power Systems and Electrical Machines," ed: Elsevier.
- [9] Alt, *et al.*, "Overview of recent grid codes for wind power integration," in *Optimization of Electrical and Electronic Equipment (OPTIM), 2010 12th International Conference on*, 2010, pp. 1152-1160.
- [10] R. Grunbaum, "FACTS for grid integration of wind power," in *Innovative Smart Grid Technologies Conference Europe (ISGT Europe), 2010 IEEE PES*, 2010, pp. 1-8.
- [11] M. T. Hagh, *et al.*, "Dynamic and stability improvement of a wind farm connected to grid using UPFC," in *Industrial Technology, 2008. ICIT 2008. IEEE International Conference on*, 2008, pp. 1-5.
- [12] A. M. S. Yunus, *et al.*, "Application of SMES to Enhance the Dynamic Performance of DFIG During Voltage Sag and Swell," *Applied Superconductivity, IEEE Transactions on*, vol. 22, pp. 5702009-5702009, 2012.
- [13] "<http://www.mathworks.com/>"
- [14] V. Mahajan, "Power System Stability Improvement with Flexible A.C. Transmission System (FACTS) Controller," in *Power System Technology and IEEE Power India Conference, 2008. POWERCON 2008. Joint International Conference on*, 2008, pp. 1-7.
- [15] R. M. Mathur and R. K. Varma, "Thyristor-Based FACTS Controllers and Electrical Transmission Systems," ed: Wiley - IEEE Press.
- [16] H. Akagi, *et al.*, "Instantaneous Power Theory and Applications to Power Conditioning," ed: Wiley-IEEE Press.
- [17] L. G. c. E.-H. Narain G. Hingorani, consulting editor., *Understanding FACTS : concepts and technology of flexible AC transmission systems* New York : IEEE Press 2000.

BIOGRAPHIES

Yasser Mohammed R Alharbi (S'11) Received his B.Eng. from Riyadh collage of technology, Riyadh, Saudi Arabia, in 2007. He also received his M.Sc. from Curtin University of Technology, Perth, Australia, in 2010. He is currently pursuing his PhD study at Curtin University of Technology. His research interest includes Power quality, Renewable energy and power system stability.

A. M. Shiddiq Yunus (S'11) was born in Makassar, Indonesia, on August 4, 1978. He received his B.Sc. from Hasanuddin University in 2000 and his M.Eng.Sc from Queensland University of Technology, Australia in 2006 both in Electrical Engineering. He is recently towards his PhD study in Curtin University, WA, Australia. His employment experience included lecturer in the Department of Mechanical Engineering, Energy Conversion Study Program, State Polytechnic of Ujungpandang since 2001. He is also member of assessor institution of Indonesia in electrical engineering since 2007. His special fields of interest included superconducting magnetic energy storage (SMES) and renewable energy.

A. Abu-Siada (SM'12) received his B.Sc. and M.Sc. degrees from Ain Shams University, Egypt and the PhD degree from Curtin University of Technology, Australia, All in Electrical Engineering. Currently, he is a senior lecturer in the Department of Electrical and Computer Engineering at Curtin University. His research interests include power system stability, Condition monitoring, Power Electronics, Power Quality, Energy Technology and System Simulation. He is a regular reviewer for the IEEE Transaction on Power Electronics, IEEE Transaction on Dielectrics and Electrical Insulations, and the Qatar National Research Fund (QNRF).