

Science and Mathematics Education Centre

**The Effectiveness of Predict-Observe-Explain Technique
in Diagnosing Students' Understanding of Science
and Identifying Their Level of Achievement**

Chong-Wah Liew

**This thesis is presented for the degree of
Doctor of Science Education
of
Curtin University of Technology**

October 2004

DECLARATION

This thesis contains no material which has been accepted for the award of any other degree or diploma in any university. To the best of my knowledge and belief this thesis contains no material previously published by any other person except where due acknowledgement has been made.

Signature _____

Date: 15th Oct 2004

ABSTRACT

The purpose of this research program was to explore the effectiveness of the Predict-Observe-Explain (POE) teaching/learning technique to diagnose students' understanding of science and identify students' level of achievement with reference to the Science Student Outcome Statements for Australian schools.

This research employed an interpretive action research approach with a sample of students from three Australian metropolitan high schools in grades 9, 10, 11, and 12, whose ages ranged between 14 and 17 years. Three data collection methods were used to generate data for interpretation, namely, written POE responses of students, in-class journals and student interviews. Data collected were interpreted using three theoretical perspectives, namely, Chi et al.'s theory of ontological categories, Hewson and Hennessey's conceptual change theory to determine the epistemological status of students' understanding of science, and Chinn and Brewer's model to classify types of students' responses to contradictory observations. This purpose of using this methodology was to obtain an in-depth, plausible and credible account of students' understanding and their level of achievement.

POE tasks were concerned with heat and the expansion of water, solubility of salt, and power and resistance of light globes. The data revealed common ideas amongst students that are contrary to scientists' science; furthermore, students showed that they were able to articulate their own ideas based on the POE tasks.

The findings in this research reveal that these POEs were effective in capturing a range of possible student observations and prediction outcomes when worded in an open-ended format. Quality information on students' understanding and on the way they responded to contradictory data was obtained when POEs were administered by teacher demonstrations and were designed to produce phenomena that were clear, immediate and had only one aspect to observe. Furthermore, the data suggest that POEs are effective in identifying students' achievement across levels within a substrand of the Australian Student Outcome Statements and enable the teacher to observe and document a spread of achievement over a range of levels rather than a

single outcome. The results of this research suggest that POEs are effective in diagnosing students' understanding of science and their level of achievement.

The POE tasks can be used by teachers to insightfully design learning activities and strategies that start from the students' viewpoint rather than that of the teacher or the scientist. Findings in this research have implications for curriculum development and learning strategies, teacher development, and the promotion and assessment of students' understanding and level of achievement.

ACKNOWLEDGEMENTS

This thesis has been written based on the findings from many participating students in several schools where I have worked over the past 10 years. I am grateful to all of them for their willingness to be involved in these teacher/researcher investigations and their articulated insights and reflected understandings.

I wish to especially thank my supervisor, Professor David Treagust, whose unending patience, insightful and caring criticism has kept me on track from the start and until the completion of this thesis. He has been a source of wisdom, enthusiasm and encouragement during difficult times encountered in the course of conducting this research and the writing of this thesis.

I am also grateful to the staff, doctoral students of the Science and Mathematics Education Centre, Professor John Wallace, Professor John Malone and Dr. Peter Taylor whose encouragement and cheerful counsel have been very helpful and enabled me to complete this thesis.

Lastly, I thank my family and friends, who have provided constant support and encouragement. I am very thankful to my dear wife Mavis and children, Der Ree, Joy, and Jun for their unfailing support and encouragement. I am also grateful for my mother, who has recently gone to be with the Lord, my brothers and sisters and friends of the Seremban Gospel Chapel for their prayer support and encouragement.

TABLE OF CONTENTS

	Page
ABSTRACT	i
ACKNOWLEDGEMENTS	iii
TABLE OF CONTENTS	iv
LIST OF TABLES	vii
LIST OF FIGURES	ix
CHAPTER 1 INTRODUCTION	1
Introduction	1
Background to the study	1
Rationale for the study	4
The Research Problem	7
Specific Research Questions	7
Significance of the study	8
Summary of Chapter 1 and Overview of the Thesis	9
CHAPTER 2 REVIEW OF THE LITERATURE - DIAGNOSING STUDENT'S UNDERSTANDING	11
Introduction	11
The construct of understanding	12
Some models of understanding	12
Background to the proposed study	15
The use of POEs in schools	15
Cognitive conflict teaching/learning strategies	18
Chinn and Brewer's model of responses to contradictory data	20
Anomalous data and POEs	22
Ontological perspective for interpreting students' understanding	34
Epistemological perspective for interpreting students' understanding	44
Action research	50

Student outcome statement and POEs	57
Summary of Chapter 2	60
CHAPTER 3 METHODOLOGY	62
Introduction	62
Ontological perspective for interpreting students' understanding	62
Epistemological perspective for interpreting students' understanding	64
Chinn and Brewer's model for understanding students' responses to contradictory information in POE tasks	64
Research methodology	66
The sample	68
Data sources and collection methods	69
Requirements for the designing POEs for credible data collection	71
Procedure for administering POEs	73
Pilot studies	75
Ethical issues	76
Summary of Chapter 3	76
CHAPTER 4 PILOT STUDY	77
Introduction	77
Trial of the water-in-glass POE task	77
Trial of the salt-in-water and salt-in-oil POE tasks	82
Summary of Chapter 4	87
CHAPTER 5 RESULTS OF THE WATER-IN-GLASS-TUBING POE TASK	88
Introduction	88
The water-in-glass-tubing POE task	88
Results of the water-in-glass-tubing POE task	90
Data analysis and interpretation	92
Summary of Chapter 5	110

CHAPTER 6 RESULTS OF THE LIGHT-GLOBES POE TASKS	112
Introduction	112
Diagnosis of students' existing conception of electricity:	115
Light-globe POE 1 task	
Diagnosis of students' responses to contradictory data:	126
Light-globes POE 2	
Reflection on the effectiveness of light-globe POEs in diagnosing students' understanding	144
The skills of the teacher/researcher who used POEs	146
Summary of Chapter 6	147
CHAPTER 7 DIAGNOSING STUDENTS' RESPONSES IN THE COURSE OF INSTRUCTION	150
Introduction	150
Overview	150
Case study 1: Diagnosing one grade-10 student's epistemological and ontological understanding and her level of achievement	151
Case study 2: Profiling student's progress over time using the globe-and-switch POE	158
An analysis of Sheila's response to the globe-and-switch POEs	165
Reflection	172
Summary of Chapter 7	173
CHAPTER 8 SUMMARY OF THE THESIS	175
Introduction	175
Overview of the scope of the thesis	175
Major findings	176
Implications for teaching and learning	179
Limitations of this research	181
Suggestions for further research	181
REFERENCES	183

LIST OF TABLES

Table 2.1	Summary of some content areas where POE related tasks are used in Book 4 of Science Australia	16
Table 2.2	Summary of some POE related tasks in Book 4 of Primary Investigations	17
Table 2.3	Taxonomy of substance predicates with examples for material substance category (After Slotta et al., 1995)	39
Table 2.4	Taxonomy of process predicates with examples for constraint-based interaction category (After Slotta et al., 1995)	39
Table 2.5	Descriptors of status of students' conceptions (adapted from Hewson & Hennessey, 1992, p. 177)	47
Table 2.6	Grade 9 students' categories	53
Table 2.7	Categories of Grade 11 students on solubility	53
Table 2.8	Categories of Grade 11 students on the dissolving process	54
Table 3.1	Description of types of responses to anomalous data of Chinn and Brewer's model	65
Table 3.2	Features of each of the responses to anomalous data (after Chinn and Brewer, 1998)	66
Table 4.1	Prediction and observations of Grade 11 students on the change in water level	80
Table 4.2	Students' reasons and explanations for predicted rise in water level in the glass tubing	80
Table 4.3	Prediction and observations about the change in water level for the two groups of students	81
Table 4.4	Students' reasons for predicting a rise in water level for two groups of students	82
Table 4.5	Predictions and observations of grade-11 students	84
Table 5.1	Prediction and observations about the change in water level (n=18, Grade 10-12)	91

Table 5.2	Students' reasons and explanations for predicted rise in the water level (n=18, Grade 10-12)	91
Table 5.3	Features of each of the responses to anomalous observations (n=18)	93
Table 5.4	Types of responses of mixed Grade 10-12 class (n=18)	94
Table 5.5	Epistemological responses of students who observed an initial drop in water level (Grade 10-12)	110
Table 6.1	Predictions and observations for Light globes POE1 on which globe would glow brighter (n=16, Grade 9-12)	117
Table 6.2	Students' prediction and observation reasons on light globes POE1 (n=16)	118
Table 6.3	Predictions and observations of second light-globes POE (n=18)	128
Table 6.4	Features of each of the responses to anomalous observations (n=18)	129
Table 6.5	Summary of students' responses to POE2 in terms of a modified Chinn & Brewer's model (n=18)	142
Table 7.1	Predictions and observations of mixed grade class (n=17, Grade 9-12)	159
Table 7.2	Features of each of the response type to anomalous observations (n=17)	160

LIST OF FIGURES

Figure 2.1	Light globes and resistor series circuit diagrams	23
Figure 2.2	A bicycle wheel serving as a large pulley. (After White and Gunstone, 1992)	24
Figure 2.3	The simple circuit diagrams (After Shepardson and Moje, 1999)	27
Figure 2.4	Ontological categories (After Chi, et al., 1994)	36
Figure 2.5	Action research cycle (After Tripp, 1996, p.2)	52
Figure 4.1	Water-in-glass-tubing POE	78
Figure 6.1	Light globes POE 1 and 2 circuit diagrams	113
Figure 6.2	Circuit and questions for light-globes POE 1	115
Figure 6.3	Students' free hand circuit diagram	119
Figure 6.4	Circuit and questions for light globes POE 2	127
Figure 7.1	Globe-and-switch POE 1 and 2 circuit diagrams	158
Figure 7.2	Sheila's circuit diagram 1	167
Figure 7.3	Sheila's circuit diagram 2	171

CHAPTER 1

INTRODUCTION

Background to the Study

This research came about because of the author's interest in improving students' learning of science in his own classroom using three teaching strategies derived from Grant, Johnson and Saunders (1991) and White and Gunstone (1992), namely, concept mapping, the predict-observe-explain technique (POE) and analogies. These efforts produced students' work, which informed the author about some aspects of students' learning and understanding of science. Some of these aspects are described in the following paragraphs based on the author's initial experience using the POE teaching technique.

In a practical lesson, a class of 18 Grade-11 Physics students were asked by the author to predict and explain what will happen to the water level in a glass-tubing fitted to a round bottomed flask filled with coloured water that was to be plunged into hot water. Sixteen students predicted an immediate rise in the water level and 13 of these 'observed' an immediate rise during their experiment conducted in groups of two. Although there was an initial fall in level of the water caused by the expansion of glass which became heated and expanded before the heat had time to be conducted through the glass into the coloured water, students tended to observe or focus on the aspect of the experiment that supported their preconceived reasons and views. These students selected an aspect of the phenomenon, the subsequent rise in water level, as their focus of attention while disregarding the initial fall in water level. They tended to see what they wanted to see during the experiment. This selective attention tendency of students in making observations also was documented by White and Gunstone (1992). As it can be difficult to miss observing the initial fall of water level in the glass tube, these findings may be due to students' poor observational skills. However, these Grade-11 physics students were among the most able science students in their year. Consequently the first aspect was becoming aware how students' prior knowledge and beliefs influenced their observations of

natural phenomena in science and hence hindered their new learning (Liew & Treagust, 1995). The second aspect gained by listening intently to student responses and carefully reading their practical reports, was becoming aware of students' explanations for their predictions and observations. These explanations were personal constructions using their background knowledge of molecules and related energy. For instance, four students explained that 'water expands when heated' because 'molecules move quicker'.

As an example of student thinking, three students predicted a rise in the water level and observed that there was an initial drop followed by a steady rise. They individually constructed (during the experiment) a dual view by asserting that the molecules move more quickly when heated, initially contracted (hence the initial drop in the water level) and then the molecules expanded (hence the steady rise of expanding water). These students appeared to have incorporated a 'squashy molecules model' into their understanding of the kinetic theory of matter. Consequently, the third aspect was acknowledging that the personal construction process for each student was a mentally active and continuous one. The fourth aspect was that these students' personally constructed ideas were different from scientists' or what was taught in the classroom. Students constructed a 'squashy molecules model' instead of using a 'molecules moving faster and further apart' model introduced by the teacher to explain the expansion of water.

In addition to the author's experience with the POE technique to study students' understanding of science concepts, Treagust, Duit and Fraser (1996), Gunstone (1988), and Driver and Oldham (1986) cited many empirical studies that revealed more aspects of students' understanding of science. Research showed that there is wide acceptance that students hold ideas and beliefs about the natural world before they are formally taught. Preinstructional ideas of science have been observed consistently across age groups and nationalities (Hewson & Hewson, 2003). The importance of these conceptions for students' learning has been recognised by many science educators (Driver, Squires, Rushworth & Wood-Robinson, 1994; Treagust, Duit & Fraser, 1996). Some of these student ideas are firmly held and often persist despite science teaching (Sencar & Eryilmaz, 2004). Thus, taught science ideas are

often used to answer questions in science tests and their pre-instructional ideas are retained to explain everyday phenomena outside the classroom. Furthermore, studies have indicated that students' pre-instructional ideas may persist into university science learning and even into adulthood despite traditional teaching. Further, students' pre-instructional concepts are frequently unrecognised by teachers (Sencar & Eryilmaz, 2004) and this can affect instruction in unpredicted ways (Treagust, Duit & Fraser, 1996). This realisation suggested the importance of acknowledging and building on pre-instructional concepts in science classes (Driver, Squires, Rushworth & Wood-Robinson, 1994).

The current literature on science learning includes many instructional approaches that take students' pre-instructional theories into consideration and are designed to convince students to change their theories (Treagust & Chittleborough, 2001). Most of these approaches share a common aspect: the use of anomalous data, that is, presenting students with evidences or experiences that contradict their pre-instructional theories. The anomalous data are intended to cause students to realise that their pre-instructional theories cannot account for the anomalous data, and to adopt instead the target scientific theory, which can explain the data. Researchers who have used anomalous data to convince students to change their theories include Brown and Clement (1992); Champagne, Gunstone, and Klopfer (1985); Gorsky and Finegold (1994); Osborne & Wittrock (1983); and Posner, Strike, Hewson and Gertzog (1982).

While it is plausible to assume that anomalous data are needed to convince students to abandon their pre-instructional theories, science students are found to frequently respond to anomalous data by discounting the data in many ways, thus preserving their pre-instructional theories (Chinn & Brewer, 1993; 1998). Among many examples cited by Chinn and Brewer (1993) was a study conducted by Champagne et al. (1985) in which students who believed that heavier objects fall faster than lighter objects were asked to observe the fall of two objects of different weights from a common height of approximately one meter. Although the blocks seemed to strike the ground at the same time, many students discounted the anomalous data and 'reasoned that the blocks had in fact fallen at different rates, but the difference in

descent times was too small to be observed over the short distance used in the original demonstration'. In the light of these findings, Chinn and Brewer stressed the need to better understand how students respond to data that contradict their pre-instructional theories for improving science instruction.

In addition to taking into account what the learner already knows, understanding students' understanding of science concepts also involves acknowledging that students' personal and social construction of knowledge is an active and continuous process. This realisation of the students' learning process gives rise to the need for a constant diagnosis of students' understanding as their learning progresses. In the classroom, Driver et al. (1994) emphasised that

Probing children's thinking is not limited to the start of teaching, it can be an integral and ongoing part of classroom activity and it can be the main purpose of some activities. (p. 10)

It was an acknowledgement of these issues of students' learning which led to the research described in this thesis - research into diagnosing students' understanding of science using the Predict-Observe-Explain teaching technique.

Rationale for the Study

Over the last two decades, a vast body of evidence in the literature has echoed the need for science educators to understand students' understanding of science concepts, processes and phenomena as a prerequisite to improving teaching and learning in science. This need has been influenced by Ausubel's theory of learning which takes into account what the learner already knows and the constructivist's view of learning which acknowledges students' personal and social construction of knowledge. In the classroom, Driver et al. (1994, p.8) emphasised the need for teachers '...to be aware of students' existing ideas ...when they are planning and implementing teaching...' and '...to respond in ways which address the sense that learners are making of their learning experiences.' This emphasis on the students' learning processes calls for the need to probe into and diagnose their current understanding of science. Information obtained from this diagnosis could then be

used by teachers to insightfully design learning activities and strategies that start with the students' viewpoint rather than the teacher's or the scientist's.

To unravel students' understanding of science, a wide range of techniques have been developed and documented by researchers (Carr, 1996; Duit, Goldberg & Niedderer, 1992; White & Gunstone, 1992). The 'interview about instances/events' (Osborne & Freyberg, 1985), for example, has been widely used with individual students, and written tests such as those developed by Tamir (1990) and Treagust (1988) have been found useful with larger groups of students. Another technique developed by White and Gunstone (1992), which has been widely used with student groups, is the Predict-Observe-Explain (POE) learning/teaching sequence.

In the POE learning/teaching sequence, students are informed about an experiment or demonstration which will be performed and, based on their current understandings, students are asked to predict what will happen and provide reasons for their predictions. The experiment or demonstration is then performed and the observations made by the students are probed. When the predictions and observations are inconsistent with each other, the students' explanations are explored. Occasional use of POEs in primary schools and high schools has been described by Aguis (1993), Costa (1994), Grant, Johnson and Sanders (1991), Liew and Treagust (1995), Palmer (1995), Tytler (1993) and White and Gunstone (1992).

Although POEs have been used in schools, their effectiveness in diagnosing students' understanding of science concepts, processes and explanations of natural phenomena is still an open question. An area in need of research is the teacher's skill in using POEs for effective diagnosis of students' understanding. For example, in a study on the use of POEs by pre-service primary teachers, Palmer (1995) found that teachers' evaluations were generally positive. However, teachers have difficulty in inventing POEs in topics other than the physical sciences. Moreover, when oral responses rather than written responses are used, teachers have difficulty obtaining feedback from each individual child; quieter children are dominated by louder individuals, and children simply repeat the answers of other children.

An issue related to this research is the assurance of credibility of information obtained on students' understanding of science using the POE technique. In other words, it is imperative to know that it is the students' conceptions and understanding that are actually being unravelled and not being created by the investigating method. Treagust, Duit and Fraser (1996, p.18) believed that when students are asked about concepts or phenomena that they have never seen or heard before, they could invent explanations and ideas to please the researcher. Information gained from probing into students' understanding needs to be credible before it can be used for improving science teaching and learning.

Improving the quality of science teaching and learning is a very much recognised and accepted rationale by the Education Department of Western Australia and it has influenced the development of the Science Student Outcome Statements (1998). This rationale is expressed explicitly in their Working Edition of the Science Student Outcome Statements (1994) by the following excerpt:

These (Statements) involve the identification of where children are in their learning, followed by planning to assist the child to make progress. This is seen to be clearly preferable to simply teaching a course, a stage or a year, which may or may not be related to the developmental stage of the student. To assist such approaches, a framework which describes a continuum of student achievements and which enables teachers to identify and recognise individual and class achievement was necessary. (p. 8)

The Student Outcome Statements are a result of a collaborative national education initiative of the States, Territories and the Commonwealth in Australia since 1989 (A Statement for Science for Australian Schools, 1994). The statement provides a framework for curriculum development in science education, setting broad goals and defining the scope and sequence of learning science in Australian schools. It is neither a classroom curriculum resource material/syllabus, nor does it provide teaching methods or assessment procedures. However, for each outcome statement in each strand and strand organiser (sub-strand) of science content, concepts and processes in each level of the science profile, pointers are provided to indicate the achievement of an outcome. Other pointers not mentioned in the profile also could indicate achievement of the outcome (Science - A curriculum profile for Australian

Schools, 1994). The pointers can be used as a guide for teachers to generate learning tasks and activities to help identify students' achievement of the outcomes.

In the Working Edition of the Science Student Outcome Statements (1994) prepared by the Department of Education of Western Australia, many questions were raised regarding pointers and work samples. Questions included, 'How relevant are they to students in Western Australia?' 'How do they match existing resources?', 'Are they reasonable examples to illustrate a particular level?', 'How do current assessment instruments assist in making judgements about achievement of outcomes?'. These questions imply a need for teachers to design learning activities and tasks that are effective in identifying students' achievement of the outcomes. Willis (1997) asserted the important need for teachers to establish reliable judgements of students' levels of achievement on the basis of the student outcome statements. To do this, the teacher needs to obtain good quality information about his or her students' learning. Relevant to this goal, this study seeks to explore the effectiveness of the POE technique, which according to Gunstone (1988, 1990) is both a probe and a teaching strategy, to obtain quality information on students' understanding. In this way students' levels of achievement can be identified on the basis of the Science Student Outcome Statements (1998).

The Research Problem

The research problem is concerned with exploring the effectiveness of the Predict-Observe-Explain learning/teaching sequence as a means of diagnosing students' understanding and identifying their level of achievement in science.

Specific Research Questions

There is a need for teachers and science educators to understand students' understanding of science as a prerequisite to improving teaching and learning (Treagust, Duit, & Fraser, 1996). Additionally, there is also a need for teachers to identify students' level of achievement and use it as a basis to plan and provide

learning activities to assist students to make progress in their science education. These needs give rise to the following specific research questions:

1. How effective is the Predict-Observe-Explain technique in diagnosing students' understanding of science across mixed grade classes?
2. How effective is the Predict-Observe-Explain technique in diagnosing types of students' responses to contradictory observations?
3. How effective are Predict-Observe-Explain technique in diagnosing individual students' epistemological and ontological beliefs and understanding?
4. How effective is the Predict-Observe-Explain technique in identifying students' level of achievement in terms of the Australian Student Outcome Statements?

Significance of the Study

The results obtained in this study about students' understanding of particular science concepts could be used by teachers to insightfully design learning activities and strategies that start with the students' viewpoint rather than the teacher's or the scientist's. Using the POE learning/teaching sequence in lessons was specifically designed to obtain credible information on students' understanding. The results may impress upon teachers to appreciate the need of obtaining credible information when using any method of probing students' understanding (Duit, Treagust, & Mansfield, 1996).

Moreover, credible information obtained on students' understanding of particular science concepts would help teachers to identify students' level of achievement according to the Student Outcome Statements and plan further learning activities to assist students' progress in science. In short, the results of this study have implications for curriculum development and learning strategies, teacher development, and the promotion and assessment of students' understanding and level of achievement from a constructivist viewpoint in the context of the Student Outcome Statements for Australian Schools.

Summary of Chapter 1 and Overview of the Thesis

This chapter began with the background to the study to describe how this research came about in terms of the author's interest in improving students' learning of science in his own classroom. Following this is the rationale for the study which highlights the need to diagnose students' understanding of science and identifying their level of understanding using the Predict-Observe-Explain technique. This leads on to the research problem and research questions which are concerned with researching on the effectiveness of POEs in obtaining credible information on students' understanding of science. The significance of the study section describes the usefulness of such credible information in terms of designing learning activities, assessment and level of students' achievement in the context of the Student Outcome Statements for Australian schools.

The rest of this chapter briefly outlines the content of the remaining chapters of this thesis. Chapter 2 describes the review of the literature that relates to the research questions stated in Chapter 1. It highlights the lack of research on the effectiveness of POEs in diagnosing the types of student responses to contradictory observations based on the model of Chinn and Brewer. Chapter 3 describes the interpretive action research methodology, the student sample, data collection methods, theories used to interpret the data and ethical issues related to the research. Chapter 4 describes a pilot study that answered Research Question 1: How effective is the Predict-Observe-Explain technique in diagnosing students' understanding of science across mixed grade classes? The efficacy of POEs in diagnosing students' understanding of science was demonstrated. Chapter 5 sought to answer Research Question 2: How effective are POEs in diagnosing types of students' responses to contradictory observations. The research question was somewhat answered. Chapter 6 provides answers to two emerging questions that follow Research Question 2 in Chapter 5: Research Question 2.1. How effective are POE tasks in diagnosing students' existing conceptions of electricity? and Research Question 2.2 How effective are POE tasks in diagnosing how students' responses to contradictory data are influenced by their existing conceptions of electricity? This chapter specifically focuses how students' responses to contradictory data are influenced by their existing conception of

electricity. Chapter 7 sought to answer the following research questions: Research Question 3: How effective are POEs in diagnosing individual students' epistemological and ontological beliefs and understanding? Research Question 4: How effective is the Predict-Observe-Explain technique in identifying students' level of achievement in terms of the Australian Student Outcome Statements? The chapter focuses on two case studies of individual students to demonstrate the effectiveness of POEs in diagnosing individual students' epistemological and ontological beliefs and understanding of science, electricity in particular. It also describes how POEs can be effectively used to profile an individual student's progress over time in terms of epistemological and ontological understanding and level of achievement. Chapter 8 describes the thesis overview, major findings, implication, limitations and recommendations for teaching, research and curriculum development.

CHAPTER 2

REVIEW OF THE RELATED LITERATURE: DIAGNOSING STUDENTS' UNDERSTANDING

Introduction

Probing students' understanding of science is important in the process of planning and implementing students' learning experiences to achieve desired learning outcomes. Constructivist epistemology of learning informs the teacher that knowledge construction is a continuous process and hence probing students' understanding needs to be an on-going part of classroom activity. The Predict-Observe-Explain teaching/learning sequence is one of many probing techniques that have been used in the classroom. Its effectiveness in diagnosing students' understanding of science will be the focus of literature discussed in this chapter.

The literature described in this chapter informs this thesis in the following ways: First, the construct of understanding is a complex and viable construct in the context of the researcher's own classroom and is needed to assist him to develop or adopt and evaluate the effectiveness of a probing technique such as the Predict-Observe-Explain (POE) learning/teaching sequence in diagnosing students' understanding of science. Second, POEs have been used in schools to investigate students' understanding of science but its effectiveness is still an open question. Third, teaching strategies that use contradictory data have often failed to promote conceptual change because students tend to discount contradictory data and retain their existing theories. This awareness gives rise to the need to investigate the effectiveness of POEs in diagnosing the ways students discount contradictory data. Fourth, students' preinstructional theories or beliefs are ontologically different from those of scientists and also students are epistemologically committed to their own theories. This realization creates a need to evaluate the effectiveness of POEs in diagnosing students' ontological and epistemological understanding of science. Fifth, the nature of 'Student Outcome Statements' and a trial of the statement by teachers, suggests the use of open-ended activities to allow teachers to observe a spread of

achievement over a range of levels. Thus POE tasks need to be worded in an open-ended format to be evaluated for their effectiveness in capturing a range of students' responses including those unintended or unexpected by the teacher-researcher.

The Construct of Understanding

The word 'understanding' or the phrase 'Do you understand?' is often used in the classroom by many teachers and even students would utter phrases like 'No, I don't understand' or 'Oh I see...' These phrases reflect that to try to understand something on the part of students and teaching for understanding on the part of teachers are common and important goals in the science classroom. Almost every statement of aims of education, whether addressed to a whole nation, state, school or classroom, includes understanding as an important outcome (Australian Education Council, 1994; Curriculum Council, Western Australia, 1998; White & Gunstone, 1992). Although, the construct of understanding is neither simple nor easily defined, it is essential for teachers to examine some models for understanding to assist in constructing their own viable understanding of the construct in the context of their own individual classrooms. Such an approach would help teachers to develop or select effective probing techniques to diagnose students' understanding and subsequently to design teaching/learning strategies to promote understanding.

Some Models of Understanding

To Nickerson (1985), understanding is an active process of connecting facts and relating existing knowledge to the new into an integrated cohesive whole. That is, it involves knowing and doing something with the knowledge. Understanding is context dependent and it varies in degree or completeness. For example, an expert physicist's conceptualisation of problems differs from those of the novice in the degree of abstractness of the concept involved. Thus the development of understanding in the novice involves and maybe is facilitated by a progressive change in his or her conceptual viewpoint towards that of the expert. Experts demonstrate their understanding by their greater ability to construct and use scientific representations to explain scientific phenomena.

In the context of expansion of water, scientists constructed and use the kinetic theory of matter, which suggest that molecules move faster and further apart when water is heated. In contrast, school students may use a 'squashy molecules model' they have constructed to suggest that molecules expand to explain that water expands when heated.

In the context of mathematics, Skemp (1976) distinguishes two kinds of understanding-instrumental and relational understanding. Knowing what and knowing how mathematical rules and algorithms are used in solving mathematics exercises is instrumental understanding while explaining why a rule can be used is relational understanding. An example to illustrate these differences is the well known mathematics, 'the area of a square with length equal to that of the hypotenuse of a particular right angled triangle is the sum of the areas of two other squares with lengths respectively equal to the other two sides of the same triangle.' A student who can demonstrate the above statement using model squares and triangles to explain Pythagoras theorem demonstrates relational understanding. Alternatively, only quoting and using the theorem to solve problems demonstrates instrumental understanding (i.e., using the rules without knowing why). One must bear in mind that Skemp's model of understanding also is applicable in the context of science learning.

Based on Skemp's model, Buxton (1978) developed a linear, hierarchical, four level model of understanding. The four levels in increasing order are rote, observational, insightful and formal. He explained that rote learning is instrumental understanding and insightful understanding is the knowing of how and why, which is fully developed relational understanding. Beyond insightful understanding is formal understanding (the ability to provide formal mathematical proof) which is often required in mathematics learning beyond secondary school.

Instead of a linear and hierarchical model, Byers and Herscovics (1997) proposed a non-linear, non-hierarchical, dynamic tetrahedral model of understanding. It constitutes four different kinds of understanding, which interact in the process of developing understanding. Again, instrumental understanding is the ability to apply

rules without knowing why. Relational understanding is the ability to deduce specific rules or procedures from more general mathematical relationships. Intuitive understanding is the ability to solve problems without apparent prior analysis (i.e., it is not guessing). And formal understanding is the ability to connect symbolism and notation with relevant mathematical ideas and to combine these ideas into chains of logical reasoning. These four kinds of understanding are represented by the four vertices of a tetrahedron while a student's current state of understanding is represented by a moving point in the tetrahedron. The relative importance of the four kinds of understanding changes with time and interact with one another, indicating the change of state of understanding of the student. The tetrahedral model seems to focus on the cognitive processes such as applying a rule, making deductions, solving with prior analysis and connecting ideas into logical chains.

Science and mathematics educators have proposed many models of understanding. But what are some actual classroom practices of understanding? In the context of secondary school mathematics, Miller and Kandl (1991) have observed that classroom practices of understanding are multidimensional. The first is 'knowing that' (factual knowledge) where students can state facts, definitions and quote formulas. The second dimension is 'knowing how' (procedural knowledge) which is the ability to use rules, algorithms and procedures to solve problems. The third dimension, which is not readily observed but proposed by Miller and Kandl (1991), is that of 'knowing why' which is the ability to derive a formula or to provide a plausible explanation. Knowing what and how reflects instrumental understanding and knowing why demonstrates relational understanding in Skemp's model (1976).

Following the review of some models of understanding, one would describe the construct of understanding as one that is complex, not confined to a definition, multidimensional, multilevel (linear, hierarchical or tetrahedral) and the various levels can interact as the state of understanding of a student changes with time. It is context dependent and varies in degree and completeness. Understanding generally involves the ability to recall factual and procedural knowledge and the ability to explain why. This includes making connections between bits of knowledge or concepts into an integrated cohesive whole. It also includes the cognitive processes

of abstract thinking, memory, constructing scientific representation, deduction from general to the specific, qualitative problem analysis and the ability to apply synthesised knowledge to explain natural phenomena in science.

Background to the Proposed Study

Over the last two decades, a vast body of evidence in the literature has echoed the need for science educators to understand students' understanding of science concepts, processes and phenomena as a prerequisite to improving teaching and learning in science. This need has been influenced by Ausubel's theory of learning which takes into account what the learner already knows and the constructivist's view of learning which acknowledges students' personal and social construction of knowledge (Driver, Squires, Rushworth & Wood-Robinson, 1994; Treagust, Duit & Fraser, 1996).

To unravel students' understanding of science, a wide range of techniques have been developed and documented by researchers (Carr, 1996; Duit, Goldberg & Niedderer, 1992; White & Gunstone, 1992). The 'interview about instances/events' (Osborne & Freyberg, 1985), for example, has been widely used with individual students, and written tests such as those developed by Tamir (1990) and Treagust (1988) have been found useful with larger groups of students. Another technique developed at the University of Pittsburgh (Champagne, Klopfer & Anderson, 1980) and used widely by White and Gunstone (1992) with student groups is the Predict-Observe-Explain (POE) learning/teaching sequence.

The Use of POEs in Schools

In the POE learning/teaching sequence, students are informed about an experiment or a demonstration that will be performed. Based on their current understandings, students are asked to predict what will happen and provide reasons for their predictions. The experiment or demonstration is then performed and the observations made by the students are probed. When the predictions and observations are inconsistent with each other, the students' explanations are explored. Occasional use of POEs in primary schools and high schools to investigate students' ideas has been

described by many teachers and researchers including Agius (1993), Baird and Mitchell (1986), Costa (1994), Grant, Johnson and Sanders (1991), Liew and Treagust (1995), Tytler (1993), and White and Gunstone (1992). POE tasks also are used either explicitly or implicitly to facilitate students' learning of inquiry and investigative skills in published school curriculum materials including *Science Australia Book 1-4* (Curriculum Corporation, 1999) for junior high schools (Year 8 to 10) and *Primary Investigations Book 1-7* (Australian Academy of Science, 1994) for primary schools students. A summary of some content areas where POE related tasks are (i.e., activities such as prediction, observation, and explanation related to the tasks) used in Book 4 of *Science Australia* is presented in Table 2.1.

Table 2.1. Summary of some content areas where POE related tasks are used in Book 4 of *Science Australia*.

Content area	Page	POE related tasks
Motion/falling object	5	Predict time difference for different-sized marbles rolling down inclined plane
Frictional force	9	Predict frictional force size between surfaces with different lubricant
Falling object	10	Which falling piece of paper will hit the ground first?
Air pressure/flight	15	What will happen if you blow between two ping-pong balls each hanging on a length of cotton thread?
Oxidation of iron	27	What will happen to the mass of iron when it is burned?
Metal/acid reaction	37	Predict what will happen when zinc reacts with sulfuric acid. Give reasons.
Metals displacing metals	39	What will happen if zinc is placed in a solution of lead acetate?
Microwave energy/heating	104	What will happen to the temperature against time graph as the amount of water heated is doubled or tripled?
Temperature control/body warmth	150	What will happen to the body temperature of a person after five minutes of strenuous exercise?
	151	Which model 'animal' (beaker of water) will cool the quickest?
Forensic investigation	176	What type of evidence the forensic scientists would look for at the accident scene?

Similarly, a summary of POE related tasks used in book 4 of *Primary Investigations* to facilitate learning of investigative skills in primary schools is presented in Table 2.2.

Table 2.2. Summary of some POE related tasks in book 4 of *Primary Investigations*

Investigative skills	Page	POE related tasks
Guess/prediction distinction	34-42	Mobius strips - paper rings with odd number of twists. Predict the number of strips that would result before cutting paper rings with even/odd number of twists. Tabulate predictions and compare with actual results after cutting rings.
Guessing based on insufficient information.	54-59	
Predicting pattern in sequence- Prediction based on prior knowledge/experience.	44-46 54-59	Predict what comes next and fill in the blank (repetitive patterns, sounds, movements, numbers or pictures).
Recognise and use patterns shown in data to make a prediction.	67-73	Make bar graphs of fingerprints patterns collected from class members. Use the bar graph to predict most or least frequently occurring fingerprint patterns of another class of students.
Compare predictions with actual data.	87-91	Predict which colour 'caterpillars' are easier to find in two different locations (lawn versus bare ground). Compare predictions with actual data collected.
Testing predictions using graphical representation of data to make predictions.	96-104	Pushing a paper cup using a marble rolling down a grooved ramp. Measure distances moved by paper cup for various heights the marble is released on the ramp. Use graph of the data collected to make predictions.
Structural patterns and their strength.	45-151	Predict strength of bridges built and test predictions.
Weather forecasting	186-189	Study weather conditions over time. Use information gathered to predict weather.

Although POEs have been used in schools, the effectiveness in how they are used and in diagnosing students' understanding of science concepts, processes and explanation of natural phenomena is still an open question.

As an example of the above studies identified on page 16, Palmer's study (1995) on the use of POEs by preservice primary teachers, found that teachers' evaluations were generally positive. However, teachers have difficulty in inventing POEs in topics other than the physical sciences. Moreover, when oral responses rather than written responses are used, teachers have difficulty getting feedback from each individual child because louder individuals dominate quieter children, and children simply repeat the answers of other children.

In the computer environment, POEs in computer programs were used as a means to investigate how collaborative learning would facilitate conceptual change in the topic of mechanics among Year 10 high school students (Tao & Gunstone, 1997). Other studies that also used computer programs to facilitate conceptual change were those of Gorsky and Finegold (1994) in the topic of mechanics and Goldberg and Bendall (1996) in the topic of geometrical optics. Although the POE strategy was not explicitly mentioned in these studies, computer programs were designed to promote student predictions and observations. In a recent study, Kearney and Treagust (1999, 2001) used 16 POE computer tasks incorporating digital video clips of real life events to promote discussion, reflection and probing of understanding of Year 10 and Year 11 science students in the topic of motion. Regardless of how POEs were used, whether in a normal class demonstration or in a computer environment, there seems to be a lack of studies on how students respond to contradictory observations, which is a key feature of POE tasks in probing students' understanding of science (Kearney, Treagust, Yeo & Zadnik, 2001). However, related studies do exist that used cognitive conflict teaching/learning strategy to promote conceptual change.

Cognitive Conflict Teaching/Learning Strategies

Cognitive conflict has been used in teaching strategies to promote conceptual change among students. These teaching strategies used situations where students' existing

ideas about some physical phenomena are made explicit and contrasted with those of scientists', as for example, comparing students' sequential electric current ideas with the scientist's instant current in a series circuit. Additionally, Scott, Asoko and Driver (1991) have cited studies which revealed that conflict-based teaching strategies also might use discrepancies in three other ways. First, discrepancies may occur between two sets of ideas already available to the student as, for example, when there is a conflict between two different representational systems that a student uses to describe temperature, namely, the qualitative-intuitive system and the quantitative-numerical system. Specifically, at the age of 9 or 10 years a student may assert that warm water added to warm water will still produce warm water (qualitative-intuitive system) and yet he or she will maintain that water at 30°C plus more water at 30°C will produce water at 60°C (quantitative-numerical system). Second, discrepancies may occur between a student's explanatory model and an event that cannot be explained by this model as, for example, a student's continuous model for the structure of a gas versus evidence that a gas can be compressed. Third, discrepancies may occur between the ideas, which a student holds, and the ideas of his/her classmates, such as the various student ideas (such as heavy objects fall faster than light objects) about the motion of objects.

Conflict-based teaching strategies assume that discrepancies or anomalous data produce cognitive conflict and students will recognise and resolve the conflict by bringing their personal conceptions closer to that of scientists. However, there is a contrasting view to this assumption in that while the teacher may be aware of conflict situations, the student may be entirely unaware. Indeed, even if the conflict is made obvious by some means, there is no absolute certainty that the student will recognise either its existence or its significance (Scott, Asoko & Driver, 1991). Even when a discrepancy is recognized, this by itself does not necessarily enable a student to change his or her existing conceptions (Driver, 1989).

On other hand, research evidence by Chinn and Brewer (1998) suggest that students can recognise and are able to resolve conflict generated by anomalous data in ways unexpected by the teacher. The use of anomalous data in the classroom assumes that science students, including children, are like scientists with the following four

characteristics: they possess theories/beliefs about how the physical world works; they can recognise or notice contradictory data or situations that are incompatible to their theories/beliefs; they recognise that contradictory data pose a threat to their current theories; and they sometimes choose to adopt or construct alternative theories to explain contradictory data.

On the basis of these characteristics of students, Chinn and Brewer argued that students like scientists can and do distinguish between theories and data and that students can use data to choose rationally between theories. They supported their argument by citing studies conducted by a number of researchers with primary school children, the results of their own research on responses to anomalous data by 168 undergraduates at the University of Illinois (Chinn & Brewer, 1998) and responses to anomalous data by scientists, nonscience adults and science students obtained from literature search on the history of science, and on science education and psychology (Chinn & Brewer, 1993). The results of Chinn and Brewer's literature search and their own research on undergraduates provided a framework to describe the types of responses to anomalous data used by students and scientists. The framework explained the frequent failure of teaching strategies that use anomalous data to promote conceptual change; like scientists, students have a tendency to discount or discredit the anomalous data and retain their existing theories. Although studies were conducted on the effectiveness of many teaching strategies that use anomalous data to promote conceptual change in school students, there are no studies available that explicitly explore their effectiveness in diagnosing the types of students' responses based on the model or framework of Chinn and Brewer(1993, 1998) summarised in Table 3.3 in Chapter 3.

Chinn and Brewer's Model for Understanding Students' Responses to Contradictory Information in POE Tasks

This section describes a framework for diagnosing and understanding students' responses to POE tasks adapted from Chinn and Brewer (1993, 1998) who argued that understanding how students respond to contradictory information, which is typical of many POE phenomena, is essential to understand how students interpret

science in the classroom. Their argument is based on two reasons: contradictory information in science lessons is very commonly experienced and, typically, students prefer to retain rather than to change their preinstructional theories and beliefs, even in the face of contradictory information.

According to Chinn and Brewer's model (1993, 1998), there are eight types of students' responses to account for how they respond to new information:

1. *Ignoring* occurs when the data contradict a favoured causal hypothesis, an explanation or the reason why the data are not accepted is given. But the data are neither explained nor accounted for and there is no theory change.
2. *Rejection* is a case when the data are not accepted as valid and an explanation for the data is articulated. The explanation could be that the data collection procedure is flawed (such as being a small data sample or inaccuracy of measurement), there are random errors or chance errors, or even fraud; also there is no theory change.
3. *Uncertainty* is a response in which the student is not sure whether the data are believable or valid. He or she has not yet committed himself or herself to judge the validity of the data and may need more information. The student is skeptical yet open-minded and does not explain how the data are obtained because there is an uncertainty as to whether the existing theory can explain the data. There is no theory change.
4. *Exclusion* is a type of response in which the new information is considered to be outside the domain of one's theory or field of theories, or one's theory is not intended to account for the data, or the problem is outside the existing discipline of study. As the data are considered to be irrelevant to the student's existing theory, the student does not have to make judgments about the validity of the data and there is neither a need to explain the data nor a need for a theory change. The student may or may not accept the data.
5. *Abeyance* is a type of response in which the student does not have an immediate explanation but assumes that an existing theory will (or hopefully will) someday explain the data. Additionally, the student may be uncertain about whether an existing theory can explain the data now or in the future. He

or she accepts the validity of the data but is undecided on providing an explanation and no theory change occurs.

6. *Reinterpretation* is a type of response when a student accepts contradictory data as something that should be explained by one's theory or by an alternative explanation consistent with the initial theory and hence no theory change occurs.
7. *Peripheral theory change* is a type of response when a student accepts anomalous data and modifies slightly an existing theory without changing the core of the current theory. Modifications to an established theory may occur by adding or abandoning auxiliary theoretical hypotheses to a theory, changing beliefs about how experiments in the theoretical domain should be conducted, adjusting the definition of a theoretical construct, altering the domain of the theory or subtyping. For example, an individual may hold a view that there are three types of physics: physics in outer space, physics of falling objects on earth and physics of objects on earth.
8. *Theory change or accept an alternative theory* is a type of response when a student accepts anomalous information and explains it by changing the core beliefs of his/her theory or shift to an alternative theory. Theory change is a changing of conceptions, even if neither the initial nor final conception has the structure of a formal scientific theory.

Anomalous Data and POEs

Anomalous data may be viewed as 'experiences that are incongruous ...with respect to current conceptions' (Chinn & Brewer, 1998, p. 624), or as 'information encountered or presented during science instruction that contradicts with students' existing theories or beliefs about the physical world' (Chinn & Brewer, 1993, p. 1) and these contradictory data are a key feature of POE tasks. While POE tasks were frequently used to probe students' understanding of science concepts, there seem to be a lack of research that focuses on how students respond to contradictory observations. The following are some related studies that provide some insights into how students respond to contradictory data.

To investigate the reason for a limited success in changing students' concepts in electricity using a cognitive conflict teaching strategy, Closset (1984) found that students 'refused results' when they were presented with contradictory information. Specifically, a series circuit with a resistor connected in between two identical globes (see Figure 2.1a) was presented to university students.

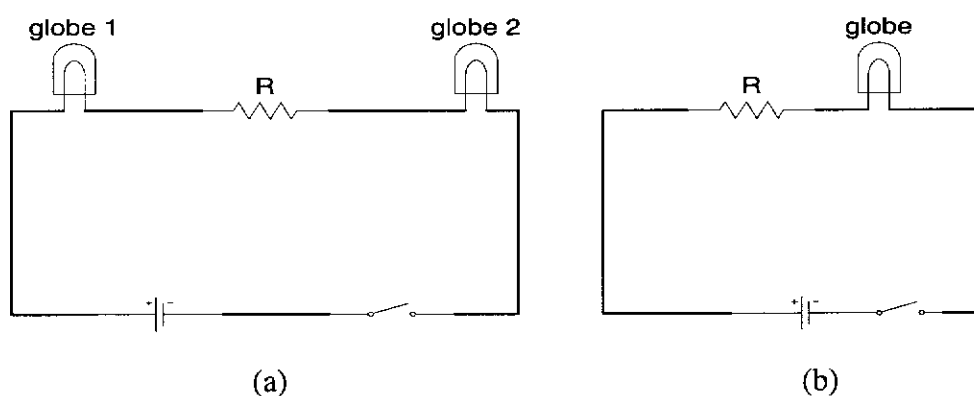

Figure 2.1. Light globes and resistor series circuit diagrams

When asked to predict if globe 1 will be brighter, dimmer or having the same brightness as bulb 2, a frequent answer was 'globe 2 will be dimmer than 1 because R consumes current or restrains the current' (p. 268). On observing that the globes glowed with equal brightness after the switch was turned on, a student 'refused the results' stating that 'Oh Yes, the resistance is not big enough for globe 2 to be dimmer'. Students were using a 'sequential current consumed' model to explain the unexpected observation and suggested that the resistance between the two globes to be increased. Another student supported the 'bigger resistance' idea by building another circuit with a 470 ohm resistance (a much bigger resistance) and a globe in series as shown in Fig 2.1b and stating that 'Look, the resistor consumes too much current and the globe cannot shine' (p. 296). A third student who explained the contradictory explanation using a 'flowing-water' analogy stating that 'The current is just like water, in the resistance it slows down and after it, it recovers the rate it has had before; so the two bulbs shine in the same way' (p. 270).

Using Chinn and Brewer's (1993, 1998) descriptions, this type of response to anomalous data falls in the 'rejection' category, where the data or observations were considered invalid and an explanation to account for the contradictory phenomenon

was provided by the responding student. The three university students in Closset's paper rejected the contradictory data and considered their observations (the bulbs glowed with equal brightness) as invalid and used 'a larger resistor between the globes' current consumer idea and a 'flowing-water' analogy to account for their contradictory observations.

To study the effect of belief or theory on observations in POEs, White and Gunstone (1992) used a bicycle wheel that could be turned freely on its mount. It formed a large pulley, with a bucket of sand and a large block of wood suspended on opposite side as shown in Figure 2.2. These POEs were administered to science and physics students from age 15 to graduate level.



Figure 2.2. A bicycle wheel serving as a large pulley. (After White and Gunstone, 1992)

The first of these POEs involved the bucket of sand and block of wood being at rest with no one touching them (that is, in balance). Just before a small teaspoon of sand was added to the bucket, students were asked to predict what would happen. Some predicted that the bucket would move down a little, and thus come to rest again at a lower position as 'it will fall to a new equilibrium' (p. 51). When the sand was added, the majority of students observed a movement of neither the bucket nor the wooden block. This was due to added sand having insufficient weight to overcome the friction at the centre of the wheel. However, many students who predicted a small

movement to a new position observed that they did see a little movement and some observed that 'the bucket moved so little that I could not see it' (p. 51). Although one may infer that students' theory had influenced their own observations, which supported their prediction, one also could infer, using Chinn and Brewer's (1993) descriptor, that students were ignoring an unexpected outcome or contradictory observation, giving an explanation (movement was too little to be noticed) for not accepting the outcome, instead of accounting for the 'no movement' observations encountered by most students.

Following the completion of the teaspoon of sand POE, students were asked to predict what would happen when a small shovel full of sand was added to the bucket. Again some predictions were that the bucket would move down a distance before coming to rest at a new balance point. Observing that the bucket moves downwards until it reached the floor, students explained their contradictory observations by suggesting that the bucket reached the floor before it reached the new balance position. To White and Gunstone (1992, p. 51), these students were reconciling their predictions and contradictory observations that involved holding on to the prediction and interpreting the observation using their prediction reason, implying that there was no conflict between predictions and their contradictory observations. Alternatively, using Chinn and Brewer's descriptor, one could infer that these students reinterpreted their anomalous observations using their own existing theory, which they also used in making predictions. Instead of ignoring what was observed by all, these students accepted their anomalous observations while still holding on to their predictions and theory.

Although White and Gunstone were focusing on how students reconciled their predictions and observations in terms of the influence of students' existing ideas and beliefs, these researchers, however, reported 'the extreme case of [students] interpreting an observation solely in terms of prediction results in the denial of the observation' (p. 52). To illustrate their point, a further POE using the bicycle wheel was administered. A different bucket of sand and a block of wood were placed at rest on the wheel, in balance and at the same level from the floor. The block was then pulled down approximately a meter and held while at this new position. Students

were then asked to predict what would happen when the block was released. The most common prediction was that the block would move back up to its original position and subsequently no movement on release was observed by all. These students rejected the validity of their contradictory observations by arguing that ‘the block was held far too long in the second position’ (some students believed that the block somehow got used to the new position). Another explanation provided by students was that ‘there was too much friction’ and with less friction the block would have return to its original position. While White and Gunstone described this type of students’ response to anomalous data as ‘denial of observation’ one could classify it as rejection of anomalous data using Chinn and Brewer’s model because students were able to account for the data which they considered invalid.

In a study on the role of anomalous data in restructuring fourth graders’ understanding of electric circuits, Shepardson and Moje (1999) encountered three response types: data presented were viewed by children as ‘anomalous’, ‘supportive’ or ‘irrelevant’. Specifically, children whose interpretive frameworks enable them to view electric circuit data as anomalous were challenged to change their understanding of electric circuits, while those whose interpretive frameworks enable them to view the electric circuit data as irrelevant did not change their understanding of electric circuits. To provide a better understanding of the three response types, summary case records of three children whose pattern of thinking, according to Shepardson and Moje, were representative of other children in their groups are described in this review. Moreover, a detailed understanding of the three response types would help the author of this thesis to interpret these response types using Chinn and Brewer’s model and descriptors. In order to understand how anomalous data were encountered by each response type, the setting (the participants and instructional strategy) in which students were engaged also is described.

The study was conducted in two different fourth grade classrooms at a rural elementary school in the midwest of the United States of America over a 12-day instruction period, with between 1 and ½ hour of instruction per day for a total instruction time of 15 hours per classroom. The two participating teachers involved in the study helped to develop an instructional unit on simple electric circuits using

their understanding of the Generative Learning Model of Osborne and Freyberg (1985). The teachers each selected four children from their classrooms (two boys and two girls) to participate in the study. The children had not been formally taught simple direct current circuits.

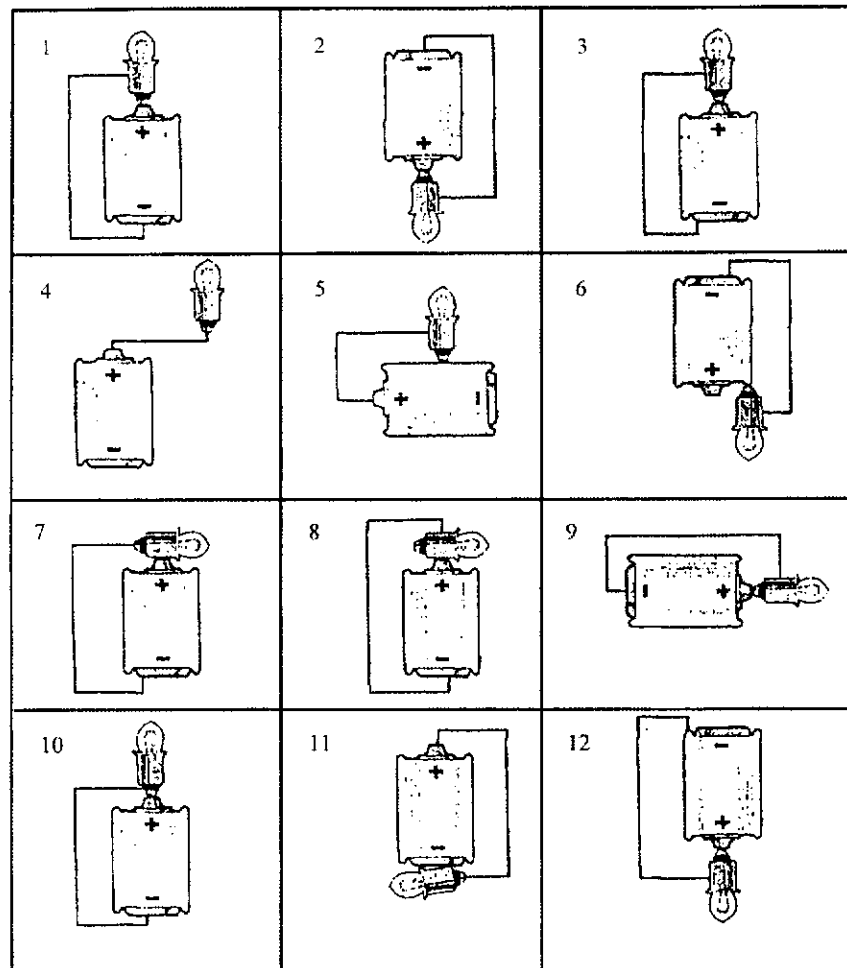

Figure 2.3. The simple circuit diagrams (After Shepardson and Moje, 1999)

Working in small groups, the children were asked by their teachers to predict whether bulbs shown in 12 simple circuit diagrams would light (Figure 2.3) and to provide written explanations of their thinking. In later lessons, they tested their predictions for each of the 12 electric circuits by making simple circuits with a battery, bulb and wires. Then in a whole class discussion following the predicting and testing activities, the teachers introduced the idea of current using the 'circus ring' analogy, that is, electricity, like the circus ring, travelled in a circular path through the circuit, leaving the 'negative end' of the battery travelling through the

bulb and returning through the 'positive end' of the battery. The following data clips describe the responses of three students (Erin, Zane and Grace), the interpretation of Shepardson and Moje (1999) and that of the teacher/researcher of this thesis using Chinn and Brewer's descriptors (1998).

Data presented were viewed as 'anomalous'

The first student was Erin whose preinstructional understanding of electric circuit was mainly that of electric circuit connection that was scientifically incorrect as indicated by the following data clip:

Erin: [Preinstruction circuit problem 1. Prediction: Won't light] If you put the wire and hook it on to the [points to negative battery terminal]... and then you hook it up to the tip of the light bulb, then the light bulb should turn on (p. 83).

Erin's preinstructional understanding of circuit connection was that of the 'tip' of the bulb and the negative battery terminal.

During the testing activities, Erin encountered five sets (circuit diagrams 1, 2, 3, 9 and 11) of anomalous data that contradicted her understanding of circuit connections. The three children's interactions surrounding the testing of circuit diagram 1 is presented as follows to illustrate Erin's encounters with anomalous data (E=Erin; V=Vance and B=Beth are other children in the group):

V: It's [circuit diagram 1] going to light.

B: Agree.

E: It won't.

B: Why do you think it won't light?

E: The wires not touching the negative part of the battery and tip...Why do you think it will light?

V: Because it's touching the top of the battery...the wire touches the bottom of the battery.

[Children build circuit and become excited when the bulb lights.]

E: Wow! It lights!

V: It told you it would.

B: So what do we put down?

V: It lights because...the wire touches the bottom of the battery and the bulb side...tip touches top of battery (p. 84).

The extract of dialog shows Erin's encounter with anomalous data (the bulb lights), as well as an encounter with a scientifically accurate electric circuit connection (from other children in her group). Moreover, during a whole class discussion that followed her predicting and testing activities, Erin also encountered the teacher's 'circus ring' analogy for explaining electric current flow in a complete circuit. According to Shepardson and Moje (1999), Erin radically restructured (changed her core concept) her understanding of circuit connection as indicated by the following data clip in a circuit problem predicting activity:

Erin: [Prediction: will light] Because it's touching the bottom and the side (points to bulb)... It needs to touch right here and right here [pointing to tip and side of bulb], the top and bottom [points to battery]. Because the electricity can go in and out [of the battery] (p. 85).

Using Chinn and Brewer's descriptors, Erin's response to anomalous data seems to be of the 'theory change' category, that is, Erin accepted the data, which conflicted with her preinstructional understanding. Subsequently, learning from her friends and her teacher, Erin was able to explain the anomalous data. Erin's understanding of electric current flow in a complete circuit had changed from her own conception to that of the scientifically correct one.

Data viewed as 'supportive'

The second student was Zane whose preinstructional understanding of electric circuit connections was that a bulb connected to a battery in a series circuit would light as long as 'the metal part of the bulb was in contact with the plus and minus battery terminals' (Shepardson & Moje, 1999, pp. 86, 87). However, Zane's preinstructional understanding of circuit connections was inconsistently expressed in the way he explained his predictions on whether the electric bulb in a particular circuit would

light during the circuit predicting activities using teacher-supplied circuit diagrams. Although Zane's explanations of electric connections were inconsistent across tasks, occasionally, he did describe or draw scientifically accurate connections. Thus, hidden within his conceptual framework of circuit connections was a scientifically accurate understanding. Moreover (according to Shepardson & Moje, 1999, p. 87), Zane also had a consistent, but scientifically inaccurate idea about electric current or 'power...flowing from both ends of the battery'.

During the circuit testing activities, Zane encountered only one set of anomalous data (circuit diagram 8) that challenged him to weakly restructure (making minor change to existing concepts) his understanding of electric circuit connections, specifically, the bulb connections: 'the bulb tip and side...touch the ends of the battery...so that the power can flow up the bulb'. The remaining circuit diagrams (1, 2, 3, 7, 9 and 11) supported Zane's understandings about electric circuit connections, as illustrated in the children's interactions surrounding the testing of circuit diagram 3 (Z = Zane; G = Grace; S = Shane and K = Karen are other children in the group):

G: This won't light because the wire is not touching the tip...has to touch tip for electricity to get in.

Z: It will light Grace...It is just like 1 and 2. The wire touches the side...the tip touches the battery...It's touching the metal part [of the bulb].

G: It won't light as no way for electricity to get in.

K: Grace! I think Zane's is right...What do you think Shane?

S: I don't know. I guess Zane...

Z: The power comes out the top and bottom[of the battery] and into the bulb. [After Grace and Zane argue over who will build the circuit, Grace takes the material and builds the circuit and becomes excited when the bulb lights.]

G: It works!

Z: I told you...it's just like the others [pointing to circuit diagrams 1 and 2] (p. 87).

This extract of dialogue shows Zane's encounters with data supported his understanding of electric circuit connections, that is, a bulb would light as long as the metal part of the bulb was in contact with the terminals of the battery. The extract

also shows that Zane's 'power model' of electricity flow, that is, power comes out the top and bottom [of the battery] and into the bulb, remain unchanged. From the viewpoint of the author of this thesis, Zane could use his 'power model' of electricity to explain any electric circuit data he encountered as long as there was an observed glow of the bulb. When the anomalous data (circuit diagram 8) of a non-glowing bulb was observed, Zane needed only to make a minor change to his understanding of circuit connections, specifically, the bulb connections were a prerequisite condition to account for the anomalous data. In other words, for Zane a bulb and battery connected in series would glow when the condition of a correct circuit connection was met. A correct connection would then allow for electricity or 'power flowing from both ends of the battery' to flow into the bulb, thus resulting in the glow of the bulb. Using Chinn and Brewer's descriptor, Zane's response type to anomalous data would seem to be in the 'peripheral theory change' category as Zane had accepted the anomalous data and made a modification of his existing understanding of electric circuit connections to account for the anomalous data. While his 'power flowing from both ends of the battery' electricity model remained unchanged, he did change his 'a bulb would light as long as the metal part of the bulb was in contact with the battery terminals' understanding of electric circuit connections to that of 'the bulb tip and side...touch the ends of the battery...so that the power [from the battery] can flow up and light the bulb' (p. 87).

Therefore, while it is valid for Shepardson and Moje (1999, p. 88) to interpret Zane's response to electric circuit data as 'Zane ignored the teacher's alternative explanation of electric current...', it is inappropriate for them to interpret Zane's ignoring as 'in much the same way as scientists do when they encounter data that conflict with a well-developed theory (Chinn & Brewer, 1993)'. From Chinn and Brewer's perspective (1993, p. 4), to ignore anomalous data is '...to dispose off a piece of anomalous data'. A student who ignores data would discredit the data that contradicts his or her existing theory gives an explanation or reason for not accepting the data and does not explain the contradictory observation. In Zane's case, he '...encountered only one set of anomalous data (circuit diagram 8)' that challenged him to make a minor change to his understanding of electric circuit connections, specifically the bulb connections (Shepardson & Moje, 1999, p. 87). This part

statement of Shepardson and Moje suggests that Zane did not ignore the conflicting data, although he did ignore the teacher's explanation of electric current.

Data viewed as irrelevant, isolated information

The third student, Grace, had inconsistently used her poorly developed preinstructional understanding of electric circuits, namely, a clashing current model (i.e., current leaves the battery at both terminals and meets in the globe, Driver, 1994) and a non-recursive current model (i.e., current leaves a terminal of the battery and goes into the globe, Driver, 1994), to explain her circuit prediction activity, which she later also used during her circuit testing activity. During the circuit testing activity, Grace encountered seven sets of anomalous data (circuit diagrams 1, 3, 4, 8, 9, and 12). According to Shepardson and Moje (1999, p. 89), Grace 'failed to view the data as being anomalous to her understanding of electric circuits' (the data did not challenge her to change her understanding of electric circuits) as shown in the children's interactions surrounding the testing of circuit diagrams 4 and 9 (G = Grace; where Z = Zane, S = Shane and K = Karen are other children in the group):

Circuit diagram 4

G: I think will light...the wire is runs from the plus to the tip.

Z: You're wrong Grace. It won't light.

S: Yea. It not gona light.

G: Why? It will get electricity from the battery... [electricity] will flow up and light the bulb.

Z: No. The power has to come from both ends of the battery. [Grace lets Shane have a turn at manipulating the materials to build the circuit, which does not light.]

Z: It didn't light. I told you it wouldn't work.

G: So we have to try them out...It doesn't matter.

Circuit diagram 9

Z: This one will light as metal part of the bulb is touching the battery.

S: You're [Zane] always right so I think it will light.

K: Why do you think [asking Grace]?

G: I don't think it will light...needs to have a wire [connecting the positive battery terminal to the bulb] so it can get more energy. [Talk continues, with Zane eventually building circuit.]

Z: Yes! Right again.

G: Why does it light?...it can't get enough energy.

Z: The power comes out both ends. It's like 1, just tipped on its side... the power goes through the wire and through the tip [positive battery terminal] into the bulb (p. 90).

Moreover, Grace appeared to interpret the data from each circuit as irrelevant and isolated, individual pieces of information. However, this extract of dialogue also could be interpreted as evidence of Grace's encounter with anomalous data in the sense that her observations of the results of circuit testing contradicted her predictions. Grace predicted that the bulb in circuit diagram 4 would glow because there was a wire connecting the positive terminal of the battery to the tip of the bulb. Specifically, Grace expressed that '...the wire runs from the plus to the tip.' and the bulb would '...get electricity from the battery...it [electricity] will flow up and light the bulb.' thus also indicating her non-recursive current flow model.

Grace continued to believe that connecting the 'tip' of the bulb to the battery would light the bulb during her prediction and testing of circuit diagram 9. Furthermore, it seems that Grace's idea of a need to have a wire connecting the positive battery terminal to the bulb to get it to light up would allow the bulb to '...get more energy' in addition to energy coming from the negative battery terminal through the already existing connecting wire to the metal side of the bulb. Apparently, Shepardson and Moje (1999, p. 90) interpreted this aspect of Grace's response as her own way of expressing her 'clashing current model' of electricity to explain her prediction of a non-glowing bulb of circuit diagram 9. When she observed the glow of the bulb during the testing of circuit diagram 9, she was puzzled by her contradictory observation as indicated by her response 'Why does it light?...it can't get enough energy.' because her clashing current model could not explain the anomalous data. Although there was some energy supplied to the bulb by the negative terminal of the battery through an already existing connecting wire, there was no connecting wire between the positive battery terminal and the 'tip' of the bulb; hence, the bulb can't

get enough energy.’ from the battery for it to glow. One could interpret and classify Grace’s response type as a case of a student who had recognised the anomalous data but was unable to explain the unexpected phenomenon, and this response type does not belong to any category of Chinn and Brewer’s framework of responses to anomalous data.

Ontological Perspective for Interpreting Students’ Understanding

The ontological perspective of interpreting and analysing students’ understanding of science examines the way in which a student perceives the nature of things being studied or what people take to be the nature of things around them (Bliss, 1995, Duit & Treagust, 2003). In other words, the student is looking ‘out’ at the world and ‘representing how things are in the world’ (Scott, Asoko & Driver, 1992, p. 323). Empirical studies discussed by Bliss (1995) and Bliss and Ogborn (1994) on an ontology of commonsense reasoning indicate four ontological dimensions, namely, dynamic versus static, place-like versus localized, discrete versus continuous and cause versus effect. Examples of students’ reasoning were: force was a cause and motion was the effect, and effort, either from within an object or from an outside source, was required for motion to continue except for falling objects. On the topic of energy, students’ ontology was one of source-user distinction with fuels seen as sources and energy-using devices seen as users.

Chinn and Brewer (1993) described ontological beliefs as ‘beliefs about the fundamental categories and properties of the world’ (p. 17) and because these beliefs are so deeply entrenched they are hard to change. Chi (1992) and Chi et al. (1994, 1995) argued that students who are unable to place concepts into appropriate ontological categories face difficulty learning scientific concepts. Chi, Slotta, and de Leeuw (1994) differentiate three major categories, namely, matter, processes, and mental states (Figure 2.4). Matter has the subcategories of natural kind and artifacts; processes have the subcategories of procedure, event, and constraint-based interaction. Constraint-based interaction is an abstract category that is difficult to define with interactions being ‘determined by a known or knowable set of constraints’ (Chi et al., 1994, p. 31). Unlike events, interactions do not have a beginning or an end, no progression, acausal (no external causing agent), are uniform

in magnitude, simultaneous everywhere, on-going, in a steady state, and at equilibrium (p. 32). As an example of a steady state interaction in an electric circuit, Shipstone (1984) described that:

if any change is made within a circuit electromagnetic waves travel from the seat of change in both direction around the circuit. A new steady state is rapidly established in which the voltages and currents in all parts of the circuit will have been altered. (pp. 190-191).

In sharp contrast to the above view, students would treat the current flowing from the battery as being unaffected by a change at one point in the circuit. This is a result of students' application of the sequential model of electric current believing that there is a sequence of events happening as the current flows around the circuit in a particular direction and current is consumed by electrical components. The view that current is a substance-like thing could be classified as a matter-based ontological category, which according to Heller and Finley (1992) also was believed by teachers as evident in the following excerpt:

The battery is the source of current. It releases a fixed amount of current (energy) that circulates around the circuit. This fixed current is not modified until it reaches a circuit component that consumes the current. The current is then successively consumed by each component of the circuit. Bulbs use up or consume current. The brightness of a bulb depends on the amount of current flowing to the bulb. When there is more than one bulb on a circuit path, each bulb consumes some of the fixed current, so all bulbs receive less current. (p. 272)

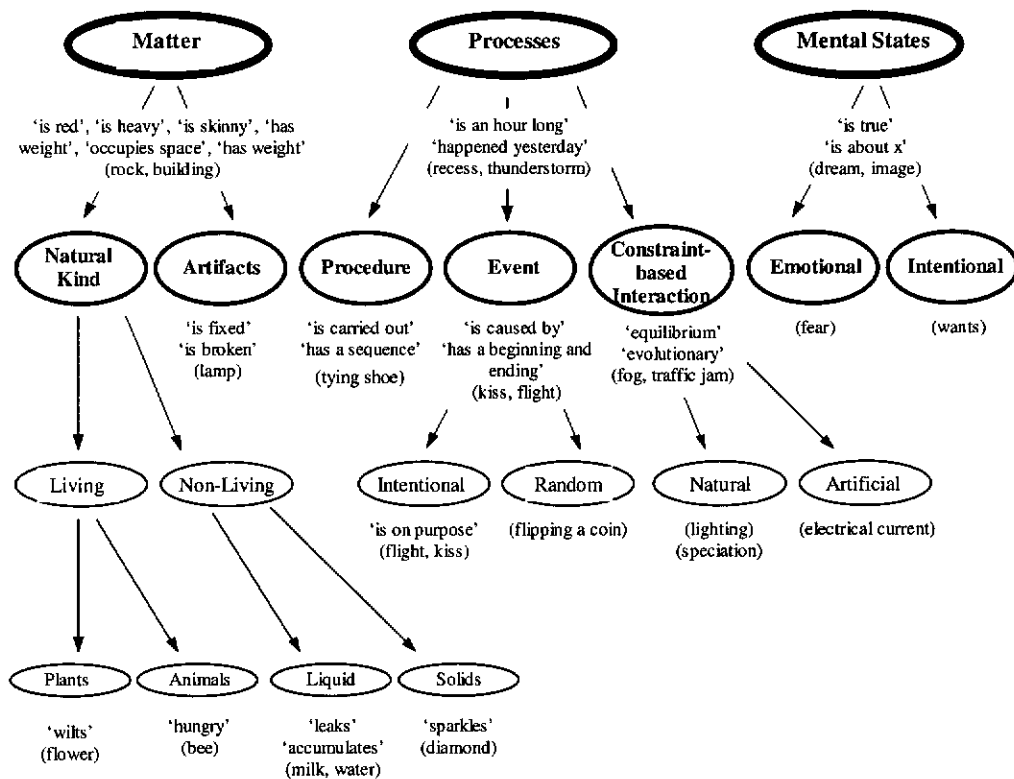

Figure 2.4 Ontological categories (After Chi, et al., 1994)

This research adopts an aspect of Chi et al.'s matter-based and constraint-based interactions (a subcategory of processes category) ontological categories to interpret students' understanding. Ontological attributes of the matter-based category include 'consumable', 'has amount', 'can flow' and 'is containable.' For example, students may view the electric current as substance-like, being stored in a battery and get used up as it flows into electrical components in a circuit. In contrast, constraint-based interactions are determined by a set of constraints, which neither has a causal agent nor time - course (beginning or ending). For example, an electric current exists only when a charged particle is introduced into an electric field. The charged particle moves due to the electric field. Hence, an electric current is neither matter nor properties of matter, but a process (Chi et al. 1994, p. 31).

Chi et al.'s theory of ontological categories (1994) is used in this research to describe students' understanding of science concepts because the theory is suitable for cognitive conflict educational strategies like the POE where students often face contradictions between their predictions and their observations. Instead of changing their ontological prediction reason/theories, students tend to discount observations in

many ways because they have difficulty placing their conceptions in the appropriate ontological categories. Furthermore, according to Chi et al., 'When the to-be-learned concepts are incompatible with their initial conceptions then ... students hold onto their initial beliefs firmly, so that they are difficult to overcome by instruction, confrontation, or any other mode of challenge (p. 35).' And these initial conceptions are persistent across age and schooling level. The prevalence of students' preinstructional conceptions in science that are inconsistent with scientists' science and that are resilient to change are also acknowledged by many researchers and science educators including Driver (1995), Gilbert and Watts (1983), Osborne and Freyberg (1985), and Treagust, Duit, and Fraser (1996).

Slotta, Chi and Joram (1995, p. 384-385) used a technique for analysing students' ontological categories by the kind of predicates that students use in their explanations of phenomena. They derived two taxonomies of verbal predicates, namely, material substance predicates and constraint-based interaction predicates which consist of words, phrases, or ideas, from novices (ninth grade students) and from experts (advanced graduate physics students), respectively (Table 2.3 and 2.4).

Students were presented with unfamiliar 'physics concept problems' involving the concepts of heat, light, and electric current. For each situation they were asked to predict its outcome and provide explanations for their predictions. As an example for the heat concept, students were asked to predict which of two airtight cups of coffee would be hotter 20 minutes after they were poured: the one in a styrofoam cup or the one in the ceramic mug. For the electric current concept, students were asked to predict the result of closing a switch in a parallel circuit containing light globes at increasing physical distance from the battery. Examples of students' explanation protocol excerpts were:

Novice 1 (heat): ...the coffee in the ceramic mug is hotter than that in the styrofoam cup, because the heat in the styrofoam cup is *gonna escape*, because it's not like, a styrofoam cup is not totally sealed because there's, like styrofoam has little holes in it, so it, the heat's *gonna go out*, escape In the holes so, and the ceramic cup doesn't have, it's just totally sealed tight...

Novice 5 (light): ...when it's traveling from the, ah, flashlight, it's just *traveling straight forward* and then it would have to, ah, *go around the bend*...

Novice 6 (electric current): ...I think that there would be current *leaking out* of this one, 'cause if the current *was going* from the battery to the light bulb, and then through the part where it was cut, and *returning* to the battery, then I don't think there would be any from, past the cut to the battery... (p. 397)

Keyword or phrases within the explanation were italicized to indicate the precise verbal data that Slotta et al. (1995, p. 397) have interpreted as evidence of the 'move' predicate for each of the three physics concepts, namely, heat, light and electric current. The 'move' predicate was considered as implying a matter-based ontological category because only substances or matter can move and processes cannot. Because many other words imply movement, any verb phrase that directly implies that the subject of the sentence is moving would be recorded as an instance of the 'move' predicate. To illustrate students' explanations that may have a subtle difference, Slotta et al. (1995, p. 396) gave the following example: 'The electric current travels along the wire' as reflecting a matter-based ontological category while 'Electric current is when electrons travel along the wire' would not be considered as an instance of the 'move' predicate, because the concept of interest (electric current) is not being said to move in anyway. Rather, the concept of electric current is being identified (the verb is) with a process of electrons moving along the wire. Thus, this latter sentence, would be considered as an instance of the process predicate 'movement process'. In other words, 'movement process' is a predicate that attributes to the subject of a sentence the properties of a process in which some other object (not the subject) is moving. In the case of electric current, it is not the current that moves or flows but it is the electrons that move, and for heat it is the molecules that move or vibrate. Slotta et al.'s (1995) analysis resulted in two taxonomies of verbal predicates, namely, the matter-based ontological category (Table 2.3) and the constraint-based process subcategory (Table 2.4). These tables also provide some examples of their verbal predicate equivalents (words or phrases) considered as instances of a given taxonomy item.

Table 2.3. Taxonomy of substance predicates with examples for material substance category (After Slotta et al., 1995).

Substance predicates	Examples
Block	'keeps,' 'bounces off,' 'hits,' 'stops'
Contain	'holds in,' 'stores,' 'keeps in'
Move	'goes,' 'leaves,' 'comes,' 'flows through'
Rest	'stops,' 'stays,' 'sits'
Consume	'gets used up,' 'gets burned up,' 'burns out,' 'drains'
Absorb	'absorbs,' 'soaks up,' 'takes in'
Quantify	'some,' 'all,' 'most,' 'less,' 'none of,' 'lots,' 'little bit,' 'as much'
Colour add	'adds like coloured paints,' 'red and blue makes purple,' 'just like with paints'
Accumulate	'fills up,' 'builds up,' 'adds on,' 'keeps building,
Supply	'gives off,' 'provides,' 'comes from,' 'comes out of'
Equivalent amounts	'the same amount to all of the bulbs,' 'divides up equally'

Table 2.4. Taxonomy of process predicates with examples for constraint-based interaction category (After Slotta et al., 1995).

Process Predicates	Examples
Movement process	'...charged particle moving in an electric field,' 'the light is a traveling electromagnetic wave,'
Transfer	'energy propagates through (the cup),' '...transfer from one to another.'
Excitation	'a lot of photon nodes to excite,' '...need a lot of energy to excite them.'
Interaction	'the interaction of electric and magnetic fields,' 'the light energy is absorbed and transformed.'
Equilibrium seeking	'The system finds its way into equilibrium.'
System wide	'These are all in parallel,' '...there's an electric field throughout the wire,' 'there's a field present throughout the wire,' 'all see the same potential.'
Simultaneous	'They all see (the potential) at the exact same time.'
Light as combined waves	'It would have red (spectral) lines and green lines in it.'

In Table 2.3, the predicates, 'block' and 'contain' for example, correspond to two attributes of material substances. Substances can block (e.g., another object) or be blocked (e.g., by a wall), and they can be contained. If, for example, in explaining a

phenomenon involving heat, students using expressions such as ‘the heat bounces off the walls of the cup’, would be classified as having a matter-based ontological conception of heat; specifically, heat can be blocked by the wall and be contained in a cup. Similarly, the predicates ‘movement process’ and ‘interaction’ in Table 2.2 correspond to attributes of processes: a process can be one in which movement occurs (e.g., of charged particles) or one of interaction (e.g., between electric and magnetic field).

Slotta, et al.’s research provided some empirical results that demonstrate ontological commitments of physics novices and experts, namely, novices do not make use of the correct process predicates to represent many science concepts whereas experts do. Their research findings inform this thesis that Chi et al.’s theory and technique are useful and relevant for interpreting and analysing POE responses of high school students who could be envisaged to use matter-based predicates to represent science concepts similar to those use by their ninth grade physics novice students.

In the case of POE responses, these predicates are the verbalised words or phrases that were used by students in articulating their explanations of their predictions and their observations, as for example, a student’s POE prediction response to the relative brightness of two globes connected in series to a battery ‘...As the current continues, it has already been used up a lot by the first globe so it doesn’t light up the second one.’ The subject part of this student’s sentence is ‘the current’, and the predicate is the phrase ‘already been used up a lot’. The predicate phrase would be taken as the student’s ontological understanding of electric current that has quantity and it can be consumed. The predicate that is observed in this student’s explanation is taken as evidence that her ontological conception of the electric current as belonging to the matter category.

While Chi et al.’s theory (1994) is very useful for interpreting and analysing students’ ontological understanding and in addressing students’ difficulties in learning key science concepts, namely, placing objects and events into inappropriate ontological categories, there is a need for a more elaborated set of categories, namely, ‘the change from a property of objects to relations between objects’ (Duit &

Treagust, 1998, p. 16) in the case of the concept of force. Chi et al. (1994, p. 34) classified students' conceptions of force, as a kind of substance that an object possesses and consumes, as belonging to the matter-based category. Duit (1995, p. 4) argued that classifying force as a thing-like entity or using Chi et al.'s descriptors, a matter-based category, is questionable. Instead he classified force as a category of property of 'things' (e.g., people or machines). In the Newtonian sense, force as the strength of a certain interaction between two objects was classified by Duit as a category of a process, namely, 'an interaction' category.

Similarly, in the case of heat concepts, the undifferentiated heat concept of daily life has to be differentiated into the concepts of temperature, heat energy, internal energy and entropy. For example, heat phenomena or process of heating and cooling (thermal interaction) and heat (a substance-like thing) as quantity or amount of net energy flow from a hot to cold object due to temperature differences. Harrison, Grayson, and Treagust (1999) found that grade 11 boys believed that objects respond differently to changes in the temperature of the surroundings, based on the object's properties, function and the imposed events. For example, flour, nails and a beaker of water after being left in an oven at 60 °C for a few hours, would result, according to a particular student, in the nails being the hottest, then the water and least the flour. The student's conception was that 'because the nails trapped heat, the water would be boiling by then, but the flour is just about 60 °C' (p. 8) and he was satisfied with his explanation even when faced with a sound contrary reason from another student. Clearly, this student's conception of heat energy and temperature was undifferentiated.

To further argue the case of a need of more elaboration and differentiation of Chi et al.'s ontological categories, Duit (1995, p. 4) discussed an aspect of the concept of light, namely, colour. In daily life colour is seen as a property or feature of an object's surface (property of a thing or matter) whereas in physics colour is conceptualized as interaction between properties of light (i.e., spectral composition) that falls at the surface and a certain property (pigments) of the surface. Specifically, physics textbooks including DeJong et al. (1994, p. 11) would explain that objects appear to be of different colours because of the way in which they absorb and reflect

different component radiation of the visible spectrum of white light. For example, blue light is reflected from a blue T-shirt by the blue pigment at its surface while the other colour frequencies of the incident white light are absorbed.

In the case of the electric current, students' conception of electric current is something provided by the battery and is consumed by the bulb in a simple electric circuit. Duit (1995, p. 6) argued that while this source-consumer conception 'certainly fits into the category of process', it is doubtful that the concept can be classified into the 'event' process subcategory of Chi et al. theory because 'usually a battery is able to provide a continuous flow [of current] for a long time'. However, Chi et al. (1994, p. 32) would argue that:

...there are events associated with the initiation of a current (e.g., closing a circuit) but these do not make the current itself an event in the same sense. The current remains a process that is influenced by or is a component of Events that have beginnings and ends, but there is no intrinsic time course to the Process itself.

Although Chi et al. and Duit would not classify the concept of the electric current into the event process subcategory, nevertheless, these researchers do agree that it belongs to the process ontological category. Similarly, Jung (1987) would consider the concept of current as a process although he termed it as an event with a different meaning from that of Chi et al. as discussed in the following review.

In order to help students to understand the concept of the electric current, Jung (1985) suggest that by 'assigning at the beginning [of instruction] the correct [ontological] category', namely, current is not a substance, but 'an event' or 'occurrence' at every point in the circuit. Instead of focusing on the direction of flow of current, students were led to focus on the properties of the occurrence' (p. 239) on each point in the circuit, exploring the relations between these properties, and the conditions by which these properties can be changed. Seemingly, Jung was referring to properties like voltage, current intensities, and resistance between any two points in the electric circuit, the relationship between these properties, and how these properties can be changed. Furthermore, the concept of the electric current is assigned as 'an event' category without too specific a meaning. For example, current

as electron drift is avoided since this requires understanding of the nature of the electron and:

...it is apt to blur the distinction between current and charge, thus again reinforcing the intuitive notion of current as a definite substance, with the possibilities of moving or being at rest, of being stored and used up. Also it brings the transportation problem in the foreground (energy transport versus charge transport), which cannot, to my mind, meaningfully discussed at the beginning. (p. 238).

By helping students to assign their conception of the electric current as 'an event' category between any two points in the circuit, it also avoids the possibility of referring current to the whole circuit as a quantity of a substance or a matter-based category using Chi et al.'s descriptors. When one compares the meaning of the term 'event' used by Chi et al. and by Jung, one could see a difference. To Chi et al., an event is an ontological process subcategory that has a beginning and an end, and also it has a causal agent. Events, like closing an electric circuit is needed to initiate a current, but the current itself is not an event. Instead, the concept of current belongs to the constraint-based process subcategory with an attribute of having no beginning or end. Whereas, the term 'event' is referred to by Jung as a category of properties and the relation between properties between two points in an electric circuit. Seemingly, to Jung, current is a process that is occurring between any two points in an electric circuit.

Although there are some limitations of Chi et al.'s ontological category theory, it is important to note that their theory does describe how students' science conceptions are ontologically different from those of scientists', namely, matter-based category versus process category. This contrasting difference is observed not only in physics, but also in other scientific disciplines. In chemistry, for example, Harrison (1996) found that students' preinstructional conception of the atom was a static electron shells matter-based model (large nucleus surrounded by close electron shells in which the electrons were evenly spaced around the nucleus) that was in contrast to a dynamic diffused electron cloud model. In biology, Venville (1996) described genes as having attributes that belong to both categories. As for example of matter attributes, genes can be passed from one generation to another and they are made up of the chemical DNA that has a double helix shaped structure. Genes also have

process attributes, for example, genes are made up of a code, which is responsible for the production of proteins, and they can be ‘switched on’ and ‘switched off’.

Epistemological Perspective for Interpreting Students’ Understanding

Epistemology is the study of the nature of the knower and the known (Abell & Eichinger, 1998, p. 107) or the study of the ground of knowledge (Bliss, 1995, p.159). In the case of the nature of scientific knowledge, for example, Chalmers (1999, p. 1) discussed what he called a widely held ‘commonsense’ view of science. That is, science is based on facts established by observations and experiments carried out in a careful, unprejudiced use of the senses, namely, sight, sound, touch, smell and taste. Similar epistemological views of science of seventh graders also were discussed by Lederman (1992) in his review of the research on students’ and teachers’ conceptions of the nature of science. Most students interviewed held the belief that ‘knowledge is a faithful copy of the world.’ That is, students thought that scientists seek to discover facts about nature by making observations and trying out things out (p. 338). In a study to compare the worldview of native Kickapoo American students and the worldview they encountered in their science classroom, Allen and Crawley (1998) used the construct of epistemology as separated into beliefs about the nature of knowledge and the means of acquiring knowledge. Students’ epistemology on the nature of science was that there was always only just one right answer or explanation to a science question in the classroom. This was evident when three students expressed their dislike of being called upon in class to answer questions because they might give the wrong answer. When asked what image was on the moon’s surface, all students except two said it was a rabbit, which was featured in Native American moon lore. The two students, both new to the community, who reported seeing a horse, were laughed at. Even a support for multiple points of view by the researchers was rejected as evident by a ‘No’ response from students who were asked, ‘Could there be other ways of understanding this?’ As to the epistemology about means of acquiring knowledge, students believed that experimenting was a way of finding out information and they also believed in authority, namely, the teacher, textbooks and Native American folklore as a basis for valid information (p. 120).

Another theory that can be used to describe students' epistemology is Perry's model of intellectual development (Finster, 1989), which outlines a scheme of intellectual and ethical development for college students. The scheme has nine positions grouped into four categories: Dualism, multiplicity, relativism, and commitment in relativism. Each of the positions represents a unique way of thinking or way in which students understand and judge their world. Using a descriptor of Perry's model of categories of students' epistemologies, the Native American students of Allen and Crawley's study were exhibiting a dualistic epistemology of science involving right-wrong opposites and they also were not demonstrating a multiple view of science. That is, diverse views are recognized and all opinions are equal, even those of an authority. An example of students' multiple and relativistic epistemology was identified by Treagust, Venville, Harrison and Tyson (1997) where a grade 11 student described organic molecules as follows:

These three are all models of molecules, the ball-and-stick method is too rigid and doesn't show that the atom is mobile, the balloon method is too [o] out of proportion, the hydrogens are huge compared to the carbon and the bonds. Some ways the atoms can be represented on paper are [Lewis structure] electron dots and this is a good representation of where the electrons are bonding to give a better idea of what is going on [Lewis structure] bonds as-. This shows the types of bonds between the atoms- each line represent two electrons being shared. These are both good methods of representing the bonding going on because they show where the bonds are and give you clues why. (p. 11)

This student was able to accept and use multiple theories to describe and represent various aspects of organic molecules. Each of the theories (ball-and-stick, electron dot, electron clouds and balloon-type models) was used to describe a few of the many attributes of covalent molecules and these models together described a molecule. The student also was able to decide when to use each model and discuss its strengths and weaknesses, thus demonstrating a relativistic epistemology.

In his proposed multi-dimensional interpretive framework to explain conceptual change, Treagust (1996, p.8) described epistemology as the study of how a student views her or his own knowledge, that is, looking inward and making qualitative judgements and commitments about various theories and conceptions that a student may have. Epistemological commitments are the standards, which a person holds which he or she uses to judge knowledge. In this regard, Posner et al.'s (1982) model

of conceptual change, which describes students' conceptions as being intelligible, plausible and fruitful, is from an epistemological perspective and these descriptors are the conditions that need to be satisfied for a student to experience conceptual change (Hewson & Thorley, 1989). Hewson and Hewson (1984) stress the importance of understanding students' epistemological commitments because:

The factors that determine whether or not a student experiences a conceptual conflict are epistemological in nature. ...It is not, therefore, surprising that the conceptual change model provides an explanation of why conceptual conflict occurs, how it can be resolved, and as a consequence, how it can be used in instructional design. (p. 12)

This conceptual change model is one way of making epistemological judgements about students' conceptions, that is, students' conceptions can be classified as intelligible, when students know what the concept means and should be able to describe it in their own words. For a concept to be plausible, the concept must first be intelligible and students must believe that this is how the world actually is, and that it must fit in with other ideas or concepts that students know about or believe. Finally, for a concept to be fruitful, it must be first intelligible and plausible and should be seen as something useful to solve problems or a better way of explaining things. When different views or perspectives have to be considered for a concept, possible outcomes may be the continuing preference for the students' existing views, an acceptance of more than one view, or a preference for a different view at the expense of the existing view. Students are likely to find that one view becomes more acceptable and other views less acceptable. In other words, the status of these views changes, with the status of some being raised and others being lowered. The more a conception meets the three conditions, namely, intelligible, plausible, or fruitful, the higher is its status. According to Hewson and Hewson (1992), the status of students' conception as being intelligible, plausible and fruitful can be determined by analysing interviews and classroom discourse. They explain that there are three steps an analyst needs to consider in determining status, namely, 1) identify representations of concepts (written statements, drawings and analogies), 2) identify comments about conceptions, and 3) interpret representations and comments (p. 62). Descriptors of the status of students' conceptions adopted from Hewson and Hennessey (1992) are shown in Table 2.5

Table 2.5. Descriptors of status of students' conceptions (adapted from Hewson & Hennessey, 1992, p. 177)

For an idea/concept to be	Descriptors
Intelligible	<ul style="list-style-type: none"> Students must know what the concepts means: <ul style="list-style-type: none"> the words must be understandable the words must make sense Students should be able to describe it in their own words Students can give examples <ul style="list-style-type: none"> examples that belong examples that do not belong Students can find ways of representing their ideas to others: <ul style="list-style-type: none"> by drawings or illustrations by talking about or explaining them by using idea maps (concept maps)
Plausible	<ul style="list-style-type: none"> The idea or concept must first be intelligible Students must believe this is how the world actually is <ul style="list-style-type: none"> it is true it must fit my picture of the world It must fit in with other ideas or concepts students know about or believe It is the way <ul style="list-style-type: none"> students see things about them students see things work
Fruitful	<ul style="list-style-type: none"> The idea or concept must first be intelligible The idea or concept should be plausible Students can see it as something useful <ul style="list-style-type: none"> it can help students to solve problems it can help explain ideas in a new way Students can apply it to other ideas It gives students new ideas for further investigation or exploration It is a better explanation of things <ul style="list-style-type: none"> it is a new way of looking at things

Many teaching/learning strategies that use anomalous data to bring about students' conceptual change assumed that anomalous data produce cognitive conflict or cognitive dissonance. Hewson and Hennessey's conceptual change model assumed that students would not consider alternative conceptions that can account for anomalous data unless they become dissatisfied with their current conceptions. Their model shares a constructivist view of knowledge change in which students actively construct and evaluate their conceptions in the light of their encounter with anomalous data. However, science educators argued that the theory change process

was more complex than what was initially assumed (Chinn & Brewer, 1998, p. 626; Duit, 1991, p. 72, 1994; Duit & Treagust, 1998, p. 15; Gunstone, 1992, p. 135; Hashweh, 1986, p.1; Hewson & Hewson, 2003, p. 586; Hewson & Thorley, 1989, p. 550; Pintrich, Marx & Boyle, 1993, p. 172; and Treagust, Venville, Harrison & Tyson, 1997, p.1). These science educators highlighted issues that are related to students' resistance to conceptual change, which range from students' views of teaching and learning that are incongruous to that of the teacher to students' unwillingness to recognize, evaluate and reconstruct their existing conceptions of science. For example, students' preinstructional conceptions are deeply rooted in daily life experiences and hence resilient to change, even in the face of contradictory data experiences. Furthermore, Kuhn (1970) argued from history of science perspective that it is common even among scientists to resist theory change by placing anomalous data in abeyance and deal with unexplained phenomena later:

...even a discrepancy unaccountably larger than that experienced in other applications of the theory need not draw any very profound response. There are always some discrepancies. Even the most stubborn ones usually respond at last to normal practice. Very often scientists are willing to wait, particularly if there are many problems available in other parts of the field. (p. 81)

Chinn and Brewer (1998) proposed that conceptual change teaching/learning strategies 'can be improved by having a better understanding of how students respond to anomalous data and why students respond as they do' (p. 626). Specifically, these researchers were referring to the types of students' responses to anomalous data and the factors that influenced students' responses. One of the factors that is of relevance to this thesis is the characteristics of students' prior knowledge, which include 'ontological beliefs' (i.e., beliefs about fundamental categories and properties of the world) and 'epistemological commitments' (i.e., beliefs about what scientific knowledge is and what counts as good scientific theory). Similarly, Hewson and Thorley (1989) argued that conceptual change teaching/learning strategies that use anomalous data were:

...necessary for creating dissatisfaction with non-scientific conceptions, but it is not sufficient. It is also critical to know how such events and anomalies are experienced by the learner. Teachers must be able to do two things: diagnose the conceptions that the students are using to interpret the phenomena, and monitor the status of old and new conceptions in the minds of students. (p. 551)

The review of the literature on epistemology so far has informed this thesis on the need to evaluate the effectiveness of the POE teaching/learning strategy in diagnosing students' epistemological understanding of phenomena in science (i.e., the status of students' conceptions and their epistemological commitments that influence conceptual status).

Hewson and Hewson (1992) discussed some examples of status determination analysis using interview data of English second language, rural students who were asked to predict, observe and explain the floating and sinking of a variety of common objects. For example, students' prediction explanations were amount of mass (objects with more mass sink), amount of substance (big amount of substance float), and the material of the object (plastic floats, chrome sinks). In the face of contradictory observations of the phenomenon, a particular student rejected all his explanations realizing that they lacked generalisability. His epistemological commitment was that there must be a single explanation, but he did not know it: 'I can say I do not know... there is a reason-I do not know what the reason is' (p. 64). Hewson and Hewson's interpretation of the comments of this student's on his own explanations of the observed phenomenon, was that the student's explanations were intelligible to him (he can formulate and describe concepts in his own words), but they were not plausible or fruitful to him because they did not meet his epistemological standard for a generalisable explanation. The examples discussed by these researchers showed that students' epistemological commitments inferred from interview data analysis influenced the status of students' conceptions of science phenomena.

Using the technique and descriptors of Hewson and Hennessey (1992), Treagust, Venville, Harrison & Tyson (1997) analyzed transcripts of verbal responses to questions by interviewers following lessons and dialogues of classroom interactions between students and teacher, about students' written work in a variety of content areas, including physics (refraction of light), chemistry (atoms and molecules) and biology (genetics) at high school level. In each case, at least two researchers independently examined the transcripts and interpreted the data from the conceptual

change model of Hewson and Hennessey. Agreement of interpretation between analysts on status of students' conceptions was in the range of 85-90% at first comparison. Results of their analysis led them to argue 'that students' conceptual status can be credibly inferred from interviews and in-class learning activities' (p. 1) and also the conceptual change model of Hewson and Hennessey 'is a viable approach for identifying status of students' conception (p. 2).

In this research, students' POE responses, in-class-journal and interviews were analysed to determine the epistemological status of their conceptions of phenomena using the technique and descriptors of Hewson and Hennessey (1992). If students were found to believe or have a commitment to their conceptions, explanations of anomalous data and their predictions, then information obtained on their understanding of concepts would be of quality, credible and hence valid for use to identify their levels of achievement. This can be achieved when students' written POE responses are not evaluated for purposes of assessment or grades for term report cards. As Gunstone (1988) had commented, 'If evaluation takes place, students will quickly fall into the pattern so common on tests, and give the science conception whether or not they have any commitment to this' (p. 90). Furthermore, Treagust (1996) believed that when students are asked about concepts or phenomena that they have never seen or heard before, which is typical of POE tasks, 'they could invent explanations and ideas to please the researcher' (p. 18). If POEs are to be effective in diagnosing students' understanding of science concepts, then students' ideas and explanations generated during POE tasks would be identified as truly their own rather than as inventions to please the teacher/researcher or to obtain pleasing assessment results or grades for term reports.

Action Research

An action research component of the research methodology is adopted because of the suitability in classroom research involving the author as a teacher-researcher. According to Cohen and Mannion (1989), a feature which makes action research suitable for the classroom teacher-researcher is its flexibility and adaptability during implementation in the background of changing constraints in schools. Furthermore, from the standpoint of curriculum designing in general, inventing suitable POEs to

diagnose students' understanding of science in particular, where students' collaboration and views are taken in account, action research is highly recommended (Driver, 1988; Driver & Oldham, 1986). Action research is also elegant, involving collaboration between the teacher-researcher and his or her students' in a process of self-reflective spiral of planning, action, observation, reflection and re-planning (Kemmis & Taggart, 1988; McNiff, 1988). Its recursive process is ideal for gaining emergent insights into students' understanding (Erickson, 1993) and helps to integrate and develop views of the teacher-researcher and his or her students simultaneously (Duit, 1991). Tobin (1989) argued that action inquiry involving teacher-researchers not only empowers teachers to become professional and reflective practitioners but it is also ethically favourable, that is, research is not done on teachers but the research is done with teachers. Similarly, from an ethical standpoint, this research project is not doing research on students but is doing research with students.

In the planning of an action research one must keep in mind that 'it is best designed by the participants in, and according to the needs of, their own situation' (Tripp, 1996). In this thesis, it is the teacher-researcher who is developing the research process and as the research progresses, students' collaboration also is requested. Although there is no set algorithm in action research, there are some key points or tenets the author of this thesis must keep in mind when implementing action research cycles, namely,

It is both an improvement and learning process [for both the teacher and his or her students]; it follows the 4-phase action inquiry cycle; it involves making changes to practice; it uses recognized research techniques; the process does not disadvantage anyone (Tripp, 1996, p. 2).

Figure 2.5 gives a schematic representation of action research process cycle.

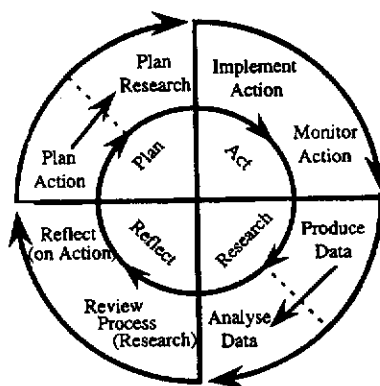

Figure 2.5. Action research cycle (After Tripp, 1996, p. 2)

To illustrate the implementation of a first cycle, a brief recount of the author's first experience with action research, published in Liew (1996), 'SCOPE: Teachers' stories' (p. 79-87), is described below.

Plan

Informed by a review of the literature on the need to design learning experiences that take into account students' prior knowledge, the author aims to probe into his students' understanding of science, specifically, the topic of solubility, with a view of improving his teaching practice by developing his skills in action research and in using sound data collection methods. The strategy is to involve his students (a class of Grade 9 students and a class of Grade 11 students) and also two other classes of Grade 9 students and their teachers. The inquiry method is to include a question in the written section of an end-of-course test for all Grade 9 students in the school. The question is 'Sugar is said to be soluble or can be dissolve in water. Explain the meaning of soluble or dissolve.' In order not to disadvantage (ethical consideration for conducting research) the teachers or the students in terms of their test performance and the standard required of writing a test, the two Grade 9 teachers were consulted by the author of this thesis for their consent and approval to use the test and also to participate in its administration. The method of data analysis selected was one of categorizing students' responses based on their similarity of wording and their use of distinctive words or concepts.

Act: Implement and monitor action

The teacher of each class administered the test as an end of unit test for all Grade 9 students. The teacher-researcher also administered the same question on solubility without the rest of the test to his class of Grade 11 students. Students were told that it is not a test but all their requested views are valued and respected.

Research: Data collection, analysis and interpretation

The teacher-researcher collected, analyzed, and grouped students' responses into categories based on their similarity of wording and their use of distinctive words or concepts. The categories that emerged from the Grade 9 students are given in Table 2.6.

Table 2.6. Grade 9 students' categories

Sugar disappears in water
Solid is broken down into smaller units
Substances mixed with water
Solid forms a solution with water
Water tastes sweet
Factors affecting degree of solubility
Substance chemically forms a compound with water
Solid particles/molecules spread out far apart in water
No response

Categories that emerged from Grade 11 students are given in Table 2.7 and 2.8.

Table 2.7. Categories of Grade 11 students on solubility

Solid disappears in the water
Solid breaks down into small fragments and mixes with water
Substance mixes with water
Number of moles of solid per liter of water

Table 2.8. Categories of Grade 11 students on the dissolving process

Sugar molecules mix with water molecules
Sugar molecules break away from each other
Molecules of sugar and water combine to form a solution
Weak bonds holding sugar molecules are broken by water molecules
Sugar combines chemically with water molecules to form a new compound

Scientists' conception of solubility is that the electrostatic attractive forces between particles (molecules, atoms, or ions) of the solute must be overcome by the larger attractive forces between solute and solvent particles for a solution to occur. Subsequently, rearrangement of solute-solvent particles takes place (Anderton, Garnett, Liddlelow, Lowe & Manno, 1996, p. 210). The outcome of this process of electrostatic interaction between solute and solvent particles is a solution, which is a homogeneous mixture (substances are completely and evenly mixed) of two or more substances, namely, solute and solvent particles (Driver, Squires, Rushworth & Wood-Robinson, 1994, p. 84). The categories and views of both the Grade 9 and Grade 11 student groups revealed that the knowledge and ideas about the meaning of 'soluble and dissolve' is about the nature of solubility of solid substances (sugar in particular). These include sensory experiences of solubility (solid disappears, breaks down into small fragments and water tastes sweet) and knowledge on the properties of solution (substances mixed with water, moles per liter and factors affecting solubility). Although both Grade 9 and Grade 11 students use the terms 'smaller units' and 'small fragments' to describe the form of the solid in solution, the use of the term molecules is more likely to be found among Grade 11 students (9 out of 10 Grade 11 students as compared to 3 out of 77 Grade 9 students). Generally, students provided molecular descriptions of the dissolving process rather than explanation using the electrostatic particle view of scientists.

Reflection 1

Students' ideas obtained from the data analysis are, to the teacher-researcher, a mixture of their own personal constructions of knowledge and recall of lesson notes and textbooks because they were in a test environment. To obtain their ideas about

the solubility phenomenon, a concrete classroom activity needs to be designed that allows students to articulate and experiment with their ideas; and facilitate their thinking process, and to decide on the kind of reasoning needed to explain and interpret an experience of the phenomenon.

The data collected in this first cycle were students' responses to an end-of-unit test question. In a test environment, it is likely that student responses are a regurgitation of ideas from textbooks and lesson notes, and lacking in personal commitment and belief (Gunstone, 1998). Second, students tend not to experiment with their thinking because tests discourage the knowledge construction process (Driver, 1988). Third, the test question is phrased in such a way that students merely have to explain a completely described phenomenon-solubility of sugar in water. This argument discredits the data from the Grade 11 students who could have reproduced textbook knowledge as well (White & Gunstone, 1992), although they were not in a test situation as was the case of the Grade 9 students.

Second cycle: Plan

For this cycle, a more effective data collection method to generate data on students' ideas and beliefs on solubility, the Predict-Observe-Explain (POE) learning sequence, explained in detail in White and Gunstone (1992) and in Liew and Treagust (1995) was chosen. Specifically, the end-of-unit test question on solubility is rewritten without using the terms 'soluble or dissolve' so that the solubility phenomenon to be observed is not described. Moreover, the written test question is turned into an experiment for the students to perform and respond as follows:

Prediction/explanation before the experiment

Predict what will happen to a teaspoon of table salt if it is dropped into a cup of water. State and explain the reason (s) for your prediction.

Observation/explanation during the experiment

Describe what happens to a teaspoon of table salt if it is dropped into a cup of water. State and explain the reason(s) for your observation

Comparison of prediction and observation after the experiment

Compare your observation with your prediction. Are they in agreement or disagreement? Explain with your reason(s).

Group discussion

Discuss your answers to the above three questions with your group members and write down your final reasons and explanations.

A second POE learning sequence was also planned using a different solvent (cooking oil) for salt. The salt/water and salt/cooking oil experiments are chosen because they are relevant to the daily out-of-school experiences of students.

Second cycle: Act

The chemistry unit for year 9 students had come to an end and the next science unit was about to commence. Consequently, data collection for this second action research cycle could not be carried out.

Reflection 2

At the end of the first cycle, the teacher-researcher had become aware and learned to be self-critical of his inadequate data collection method (a question on solubility for students to answer) based on information obtained from literature review on methods of probing students' understanding of science (White & Gunstone, 1992). Subsequently, the teacher-researcher developed an improved data collection method by changing the test question into a POE experiment that required students to conduct in small groups and to provide written responses. Furthermore, the efficacy of data analysis and interpretation need to be improved by using more informed theoretical perspectives, as for example, epistemological and ontological commitment of students' in explaining their observations during POE experiments (Chi et al., 1994; Hewson and Hewson, 1992).

The two POEs (salt/water and salt/oil) planned for the second cycle would provide an opportunity that serves as a challenge to students' thinking on solubility due to contradictory observations between the two experiments. Valuable information on students' explanations on solubility can be obtained not during this action research cycle but in a near future opportunity. This first cycle experience of the author of this thesis provided some useful insights in applying action research to improving his classroom practice, specifically, in becoming more aware and critical of the efficacy of techniques he used in probing students' understanding of science (Cohen & Mannion, 1998, p. 220; Kemmis & McTaggart, 1988, p. 22; McNiff, 1988, p. 4).

Student Outcome Statements and POEs

The Student Outcome Statements are a result of a collaborative national education initiative of the States, Territories and the Commonwealth in Australia since 1989 (A Statement for Science for Australian Schools, 1994). The statement provides a framework for curriculum development in science education, setting broad goals and defining the scope and sequence of learning science in Australian schools. It is neither a classroom curriculum resource material nor a syllabus, nor does it provide teaching methods or assessment procedures. However, for each outcome statement in each strand and strand organiser (sub-strand) of science content, concepts and processes in each level of the science profile, pointers are provided to indicate the achievement of an outcome. Other pointers not mentioned in the profile also could indicate achievement of the outcome (Science-A curriculum profile for Australian Schools, 1994). The pointers can be used as a guide for teachers to generate learning tasks and activities to help identify students' achievement of the outcomes. According to the 'Outcomes and Standards Framework-Overview' of the Education Department of Western Australia (1998),

Pointers are illustrative descriptors of ways in which students might demonstrate performance in relation to particular outcome statements. They are neither prescriptive nor exhaustive. It is anticipated that teachers will develop their own pointers, either by themselves or in teams, to ensure they describe the ways in which students can demonstrate achievement of outcomes in the particular context of learning used and assessment. (p. 7)

In the Working Edition of the Science Student Outcome Statements (1994) prepared by the Department of Education of Western Australia, many questions were raised regarding pointers and work samples. Questions like, 'How relevant are they to students in Western Australia?', 'How do they match existing resources?', 'Are they reasonable examples to illustrate a particular level?' and, 'How do current assessment instruments assist in making judgments about achievement of outcomes?' These questions imply a need for teachers to design learning activities and tasks that are effective in identifying students' achievement of the outcomes.

The curriculum framework document of the Curriculum Council (1998) in Western Australia recommends a constructivist approach to learning and teaching as indicated by the following excerpts:

First,

The outcomes in the Science Learning Area Statement are best achieved when science programs reflect the developmental nature of scientific understandings and encourage students to generate conceptual frameworks rather than require them to learn many science facts. (p. 238)

This excerpt suggests that science learning emphasizes development of conceptual understanding rather than the learning of facts.

Second,

Learning is a process that involves constructing and modifying ideas. While this can be a personal activity, learning is enhanced by collaboration with other people. Working scientifically with adults and peers allows students to test personal constructions of scientific concepts with the constructions of others. (p. 241).

This excerpt suggests that teachers need to identify students' current ideas and understanding so that they can design activities that build on them. Often students bring their preinstructional knowledge to the classroom that influences their interpretations of new scientific experiences organized by the teacher. Moreover, opportunities for quality interaction of the individual students between the teacher, peers and others in the forms of questioning, cooperative learning group work, peer debate or critical analysis of scientific investigations, need to be facilitated to help students to develop, change and expand their personal ways of thinking to become more consistent with more powerful scientific ways of thinking, so that they can accept and apply scientifically valid ideas in appropriate contexts.

While the curriculum framework of the Curriculum Council in Western Australia recommends a constructivist approach to learning and teaching, it also specifies the Science Learning Area outcomes among seven other learning areas. The outcomes of the Science Learning Area statement are organized into two parts, namely, the 'Working Scientifically' outcomes and the 'Understanding Concepts' outcomes. The 'Working Scientifically' outcomes describe the skills of inquiry and the ways scientific information is used in daily life. The 'Understanding Concepts' outcomes describe the understanding of theories, ideas and knowledge drawn from the traditional scientific disciplines.

Although the outcomes are explained and elaborated, there is no description of progression of levels of achievement. Teachers would not be able to use the 'Science Learning Area' outcomes as a progress map to describe and to assign individual students' level of achievement. This need of a progress map is addressed by the Education Department of Western Australia's (1998) 'Student Outcome Statements' for teachers in the State Government schools.

On the issue of assigning and describing students' levels of achievement, Willis (1997) stresses the importance of teachers' professional judgement about students' achievement, which involves the complementary aspects of how to make learning happen and how to tell when it has. Professional judgement about students' level of achievement should be made by rigorous evaluation of varied students' products and performances against the outcomes. Even if a task is designed to evaluate specific outcomes, one cannot be sure what outcome will be reflected in students' responses. Consequently, tasks that enable students at a range of levels to demonstrate what they can do should be used and particular student's achievements can be judged directly without reference to other students or overall scores (p. 95).

A trial on the use of 'Student Outcome Statements' (Education Department of Western Australia, 1996-Science Report. Report of the Student Outcome Statements Trial 1994-1995, p.22) by teachers in Western Australia suggests the use of open-ended activities to allow teachers to observe a spread of achievement over a range of

levels. With one task, different outcomes can be demonstrated by students for teachers to observe. Many teachers who were involved in the trial expressed a need to change their teaching pedagogy to an open-ended, student centered approach (p.101).

This study seeks to explore the effectiveness of the POE technique, which according to Gunstone (1988, 1990) is both a probe to obtain students' understanding and a teaching strategy reflective of a constructivist approach, in identifying students' level of achievement. Informed by the literature review on the nature of 'Student Outcome Statements' and a trial of the statements by teachers in Western Australia, the author of this thesis used POE tasks that are worded in an open-ended format to capture a range of responses that are not expected or intended by the teacher.

Summary of Chapter 2

The construct of understanding is neither simple nor easily defined and teachers need to construct their own viable understanding of the construct in the context of their own classroom that would help them to develop or select effective probing techniques to diagnose students' understanding and subsequently to design teaching/learning strategies to promote understanding. The POE teaching/learning sequence is one among a wide range of techniques used to unravel students' understanding of science. Although POEs have been used in schools, their effectiveness in how they are used and in diagnosing students' understanding is still an open question.

Studies on the effectiveness of many teaching strategies that use anomalous data to promote conceptual change in school students have been conducted but there seem to be no studies done to explicitly explore how POEs are effective in diagnosing the types of students' responses to contradictory data based on the framework of Chinn and Brewer. In the face of contradictory information, students prefer to retain rather than change their preinstructional theories or beliefs. This thesis adopts an aspect of Chi et al.'s ontological categories to interpret student's conceptual understanding because students are found to have difficulty placing their prediction reasons/theories

into appropriate ontological categories and often they tend to discount contradictory observations in ways unanticipated by the teacher.

While students' ontological understanding is interpreted using Chi et al.'s ontological categories, students' epistemological understanding is interpreted in terms of the status of students' conception using the conceptual change model of Hewson and Hewson. Students POE responses, in-class-journal and interviews are analyzed to determine the epistemological status of their conceptions of phenomena. If students are found to believe or have a commitment to their conceptions, explanations of anomalous data and their predictions, then information obtained on students' understanding of concepts would be of quality, credible and hence valid for use to identify their levels of achievement using the Science Student Outcome Statements of the Education Department of Western Australia. The nature of the Student Outcome Statements and a trial by teachers in Western Australia using the Statements suggests that open-ended learning tasks, which enable students at a range of levels to demonstrate their knowledge and ability, should be used to identify their levels of achievement. Moreover, particular student's achievement can be judged directly without reference to other students or overall scores. Hence, in this research, POE tasks are worded in an open-ended format to evaluate their effectiveness to capture a range of student responses and understanding of phenomena unanticipated by the teacher.

CHAPTER 3

METHODOLOGY

Introduction

This study adopts a framework to analyse and interpret students' understanding of science adapted from Tyson, Venville, Harrison and Treagust (1996) in that the social/affect dimensions are not explored which are consistent with the Research Questions. Instead, only the epistemological and ontological dimensions of students' understanding are explored. The ontological aspect (how a student views the outside world) of students' understanding is interpreted as beliefs, judgments, dimensions and categories (Bliss, 1995; Chinn & Brewer, 1993). Ontological beliefs and dimensions are found to be useful in explaining students' conceptions (Chi, 1992; Chi, Slotta, and de Leeuw, 1994) and students' resistance to change their viewpoints (Bliss, 1995) when conflicting observations and data are experienced in the course of learning. How students resist change is interpreted as types of responses to anomalous observations using Chinn and Brewer's model (1993). The epistemological perspective (how a student views his or her own knowledge) is interpreted as how students make qualitative judgments and commitments about various theories and their conceptions (Hewson, 1985; Posner, Strike, Hewson & Gertzog, 1982).

Ontological Perspective for Interpreting Students' Understanding

The ontological perspective of interpreting and analyzing students' understanding of science examines the way in which a student perceives the nature of things being studied or what people take to be the nature of things around them (Bliss, 1995, p.159), that is, the student is looking 'out' at the world. This research adopts an aspect of Chi et al.'s matter-based and constraint-based interactions (a subcategory of processes category) ontological categories to interpret students' understanding. Ontological attributes of the matter-based category include 'consumable', 'has amount', 'can flow' and 'is containable.' Constraint-based interactions are determined by a set of constraints which has neither a causal agent nor time - course

(beginning or ending). For example, an electric current exists only when a charged particle is introduced into an electric field. The charged particle moves due to the electric field. Hence, an electric current is neither matter nor properties of matter, but a process.

Chi et al.'s theory of ontological categories (1994) is used in this research to describe students' understanding of science concepts because their theory is suitable for cognitive conflict educational strategies like the POE where students often face contradictions between their predictions and their observations. Instead of changing their ontological prediction reason/theories, students tend to discount observations in many ways because students have difficulty placing their conceptions in the appropriate ontological categories. According to Chi et al., 'When the to-be-learned concepts are incompatible with their initial conceptions then ... students hold onto their initial beliefs firmly, so that they are difficult to overcome by instruction, confrontation, or any other mode of challenge (p.35).' Evidence of students placing their science conceptions into inappropriate ontological categories reported in empirical studies has been discussed by Bliss (1995) and Bliss and Ogborn (1994). They found that children's ontological judgment about the world, that is how children imagine the nature of objects and events, can be differentiated into four ontological dimensions, namely, dynamic versus static, place-like versus localized, discrete versus continuous and cause versus effect. As an example of the 'cause versus effect' dimension, students conceive that 'effort is required to continue a motion' (Bliss & Ogborn, 1994, p. 11). Chi et al. (1994, p. 40) use a technique for analysing students' ontological categories by the kind of predicates that students use in their explanations of phenomena. In the case of POE responses, it is the verbalised words or phrases that were used by students in articulating their explanations of their predictions and what they have observed. For example, a student's POE prediction response to the relative brightness of two globes connected in series to a battery '...As the current continues, it is already been used up a lot by the first globe so it doesn't light up the second one.' The subject part of this student's sentence is 'the current', and the predicate is the phrase 'already been used up a lot'. The predicate phrase would be taken as the student's ontological understanding of electric current that has quantity and it can be consumed. The predicate that is observed in this

student's explanation is taken as evidence that her ontological conception of the electric current as belonging to the matter category.

Epistemological Perspective for Interpreting Students' Understanding

In this research, students POE responses, in-class-journal and interviews were analysed to determine the epistemological status of their conceptions of phenomena using the technique and descriptors of Hewson and Hennessey (1992) as shown in chapter 2 Table 2.3

Chinn and Brewer's Model for Understanding Students' Responses to Contradictory Information in POE Tasks

The researcher's summary of Chinn and Brewer's model of students' responses to anomalous data, which gives a brief description of each type of response, is shown in Table 3.1.

According to Chinn and Brewer (1993, 1998) students respond to contradictory information by coordinating their existing theories and beliefs with the information they experience. There are three questions (not necessary in any particular order), either explicitly or implicitly, a student must answer in order to coordinate new information and theory:

1. Are the data believable (valid) for coordination to proceed?
2. Can the data be explained?
3. Does the theory need to be changed for successful coordination?

Students' answers to the above three questions when responding to contradictory data were classified into three dimensions:

1. The student accepts the data as valid;
2. The student can explain why the data are accepted or not;
3. The student changes his or her prior theory.

How the eight types of responses differ across these three dimensions is shown in the Table 3.2.

Table 3.1. Description of types of responses to anomalous data of Chinn and Brewer's model, (1993, 1998)

Type of response	Description
Ignoring	Discredit data that contradicted existing theory/hypothesis. The student gives an explanation or reason for not accepting the data and does not explain the contradictory phenomenon.
Rejection	Consider data invalid with an explanation to account for the contradictory phenomenon. Examples: 1. Methodological error Data collection procedure is flawed, small data sample, faulty methodological assumptions, and inaccuracy of measurements. 2. Random error or chance error
Uncertainty	Non-committal about validity of data and want more information. Skeptical yet open-minded. Uncertain about whether the existing theory can explain the data.
Exclusion	Data are outside the domain of one's theory. Existing theory is not intended to account for the data.
Abeyance	One does not have an immediate explanation. Existing theory will (or hopefully) explain the data someday. Uncertain about whether the existing theory can explain the data now or in the future.
Reinterpretation	Data should be and can be explained by one's existing theory.
Peripheral theory change	Make a minor change or modification in the existing theory. The core of the existing theory remains unchanged.
Theory change	A changing of conceptions, even if neither the initial nor final conception has a structure of the formal scientific theory.

Table 3.2. Features of each of the responses to anomalous data (after Chinn & Brewer, 1998)

Type of response	Does the student accept the data?	Does the student explain the data?	Does the student change theory?
Ignoring	No	No	No
Rejection	No	Yes	No
Uncertainty	Undecided	No	No
Exclusion	Yes or No	No	No
Abeyance	Yes	Not yet/Undecided	No
Reinterpretation	Yes	Yes	No
Peripheral theory change	Yes	Yes	Yes, partially
Theory change	Yes	Yes	Yes

Research Methodology

This research project adopts an interpretive action research approach to generate understanding of students' understanding and level of achievement in science. The interpretive research aspect of this approach is based on the qualitative methods of participant observational research on teaching reviewed by Erickson (1986). The distinctive characteristic of interpretive research is its concern with generating understanding about the significance of what is happening in a particular social setting, such as the classroom, from the perspectives of the participants, namely, the teacher-researcher and students. To generate a plausible and credible account of students' understanding of science, several methodological strategies were drawn from the field of interpretive research (Denzin, 1988; Denzin & Lincoln, 1998; Duit, Treagust & Mansfield, 1996; Erickson, 1986; Mathison, 1988; Spector, 1984).

First, a grounded theory approach was used to generate students' emergent conceptions. Students' theories and conceptions of science phenomena were initially generated from data collected during POE activities, then these were elaborated and modified as more incoming data were collected and analyzed (Denzin & Lincoln, 1998, p. 159; Spector, 1984, p. 460). The researcher's interpretation was considered to be tentative rather than an objective truth, ensuring sensitivity to one's own

interpretation about students' understanding of science (Duit, Treagust & Mansfield, 1996). In order that students' perspectives of their own conception of science phenomena were systematically sought, attended to, and students' voices were heard, verbatim extracts of students' interview transcripts, extracts of students' written POE responses, excerpts of students' reflective journals and portfolio were incorporated in the data analysis and results chapters of this thesis (Denzin & Lincoln, 1998, p. 172-173). As this thesis is a single-author report, incorporating data from students also would reduce the tendency of the teacher-researcher's interpretation masking students' interpretation of their experiences of science phenomena encountered during POE tasks (Brickhouse, 1991, p. 55).

Second, triangulation in the form of multiple data sources, multiple methods of generating data, and multiple theoretical perspectives to obtain in-depth understanding of students' understanding of science phenomena generated by POE tasks was employed (Denzin, 1988; Denzin & Lincoln, 1998, pp. 4, 46; Mathison, 1988). Data sources in this research project included the teacher-researcher's reflective journal entries, in-class discussions with students and interviews with individual students. Data collection methods employed were based on the Predict-Observe-Explain learning-teaching sequence and the interview about events (Carr, 1996; Osborne & Freyberg, 1985; White & Gunstone, 1992). For data interpretation, three theoretical perspectives were used, namely, Chi et al.'s theory of ontological categories, Hewson and Hennessey's (1992) conceptual change theory to determine epistemological status of students' conceptions of science, and Chinn and Brewer's (1993, 1998) model to classify types of students' responses to contradictory observations.

Third, an action research approach was used to establish a rapport with students so that interviews are informed good conversations; and unethical actions were avoided by maintaining researcher's concern for safeguarding students' learning opportunities and his guarantees of confidentiality and anonymity.

An action research component of the research methodology was adopted because of the suitability in classroom research involving the author as a teacher-researcher.

According to Cohen and Mannion (1989), a feature which makes action research suitable for the classroom teacher-researcher is its flexibility and adaptability during implementation in the background of changing constraints in schools. Furthermore, from the standpoint of curriculum designing in general, inventing suitable POEs to diagnose students' understanding of science in particular, where students' collaboration and views are taken in account, action research is highly recommended (Driver, 1988; Driver & Oldham, 1986). Action research is also elegant, involving collaboration between the teacher-researcher and his or her students' in a process of self-reflective spiral of planning, action, observation, reflection and re-planning (Kemmis & Taggart, 1988; McNiff, 1988). Its recursive process is ideal for gaining emergent insights into students' understanding (Erickson, 1993) and helps to integrate and develop views of the teacher-researcher and his or her students simultaneously (Duit, 1991). Tobin (1989) argued that action inquiry involving teacher-researchers not only empowers teachers to become professional and reflective practitioners but it is also ethically favourable, that is, research is not done on teachers but the research is done with teachers. Similarly, from an ethical standpoint, this research project is not doing research on students but is doing research with students.

The Sample

The sample comprised students in classes from three local metropolitan high schools in Grade 9, 10, 11 and 12 whose ages range between 14 and 17 years. They all had completed lower school science as one of their core (compulsory) subjects after being taught science during their primary school years. Specifically, the sample consisted of three classes of Grade 9, two classes of Grade 11 physics students, and a class of Grade 12 physics students from two schools, in one of which the researcher once taught, which used the curriculum of the Education Department of Western Australia. In a third school in which the researcher also once taught, his role was to conduct once a week science practical lessons to a mixed Grade 9-12 level class of 18 students. POEs were administered to this class in a two-period (an hour and a half) science practical lesson almost fortnightly over nine months.

Data sources and Collection Methods

Data sources in this research project included the teacher-researcher's reflective journal entries, students' in-class reflective journals, in-class discussions with students and interviews with individual students. The teacher reflective journal entries are records describing how each POE was administered based on the procedure for administering POEs described on page 72-74. They are also records of preliminary data analysis of student written responses after each POE administration. In-class discussions were based on questions which were designed to stimulate students to verbally articulate their thoughts and theories in their POE written responses. before they write their individual in-class reflective journals. Data collection methods employed were based on the Predict-Observe-Explain learning/teaching sequence (White & Gunstone, 1992) and the interview about events (Carr, 1996; Osborne & Freyberg, 1985). To ensure credibility and usefulness of the information obtained by these data collection methods, the following issues highlighted by Duit, Treagust and Mansfield (1996) were taken into account:

- The interpretation process. The researcher's interpretation was considered to be tentative rather than an objective truth, ensuring sensitivity to one's own interpretation about students' understanding of science.
- Interpretation strategies. From the data, a first attempt at understanding theories of students' understanding using a grounded theory approach is evolved and then is developed further in several rounds in a spiral-like process.
- Symmetrical relationships between researcher and students. As the researcher investigates the student's understanding, the student also tries to discover the researcher's understanding. The constructivist researcher is a facilitator of ideas, rather than an imposer of thoughts. In action research, students' ideas are viewed with equal rights and respect (Driver, 1995).
- Bringing students' conceptions to light. Students' ideas, though changing, must be identified as being truly their own and not an invention to please the researcher.

- Investigating understanding viewed as learning situations. Students' construction of knowledge is active and continuous and consequently, every use of an investigative method should be viewed as a learning/teaching situation.

Students' understandings were categorised by listing and grouping their responses based on the similarity of wording and the use of distinctive words or concepts. The categories were shown to the students from whom they were derived in written form and discussed in a whole class setting. The class members were asked to check if the results were plausible (Guba & Lincoln, 1989, Merriam, 1988). Each student compared his or her individual POE responses to each question to categories that were written on the board. For each category to each question, the teacher/researcher asked the members of the class if their answers fitted the categories. Categories that were not representative from the students' viewpoint were modified, changed or even deleted; those categories that were not in the list were added on request by students based on their individual re-reading of their responses during class discussion. This member check process (Guba & Lincoln, 1989, p. 239) provided the opportunity for students to correct errors of interpretation of their POE responses due to the teacher/researcher, and to bring out additional constructions of categories during the class discussion.

Moreover, based on previous lessons, the researcher's tentative understanding of an aspect of the class's understanding of electricity ('something that flows') was written on the board in a form of a statement for students to review. The statement was:

Electricity is 'something' coming from the battery, consumed by the globes in differing amount and reaches the globe that is connected nearer to the battery before flowing into the next globe in reduced amount.

Students' agreement or any objections to the statement with accompanying reasons were requested. A common agreement to the statement was that the 'something' coming out of the battery and flows in the circuit is called current. On the basis of this aspect of understanding students' conceptions, a second POE was designed (see Figure 5.1b) to diagnose students' responses. The class was informed that the second light-globe POE would be demonstrated and the commonly agreed statement written on the board may be used as a hypothesis for making their predictions.

Requirements for Designing POEs for Credible Data Collection

To provide opportunity for students to use their existing knowledge to interpret phenomena, events and experiences the following requirements were taken into consideration when designing POEs:

Provide contradiction between prediction and observation.

One of the purposes of this research was to study the effectiveness of POEs in diagnosing how students respond to anomalous data according to Chinn and Brewer's model. An earlier study by the teacher/researcher (Liew & Treagust, 1995) revealed that there were variations in student observational outcomes when a POE had more than one aspect for observation (an initial drop followed by a rise of water level in a glass tubing fitted to a flask fully filled with water which was immersed in hot water).

The results of the study point to the need to design POEs that would produce contradictory observation outcomes that are immediate, clear, and have only one aspect to observe to reduce variations in student observational outcomes. For example, the light globes in POE1 and POE2 described in Chapter 5, light up as soon as the switch was turned on, glowing with sufficient brightness to ascertain to seeing any variations. This POE design requirement produced credible data for the researcher to interpret students' ways of discounting contradictory observations using Chinn and Brewer's model.

Open-ended format wording

For POEs to be effective in capturing a range of possible student prediction outcomes, including those that were unexpected by the teacher/researcher, an open-ended format for writing POEs was used. Choices of possible prediction outcomes were not given and students were not asked to explain their predictions in any specific manner. Additionally, the phenomenon to be observed was not completely described to avoid student regurgitations of textbook knowledge and lesson notes. An example of the teacher's question to students before introducing the POE was

‘Predict what will happen to the water level in the glass tubing if the round bottomed flask is plunged into hot water... State and explain the reason(s) for your prediction.’

Avoiding outcome guessing

A constant exposure to POEs, which always give unexpected observational outcomes, could result in students developing negative attitudes towards POE tasks and also could result in observational outcome guessing. A way to avoid student guessing of observational outcome was to have a combination of expected and unexpected observational outcomes when administering POEs in a series. In doing so, undesirable attitudes in making predictions could be avoided. Students then could predict in terms of ‘what do I reason out will happen’ and not ‘what unexpected thing might happen’.

Take into account students’ poor observational skills

When the water-in-glass-tubing POE was trialed on a group of 9 Grade 6-7 and on a group of 15 Grade 8-9 students, 6 of the Grade 6-7 students as compared to 4 of the Grade 8-9 students did not observe the initial drop on water level. These results led the researcher to alert students to focus their attention on the meniscus of the water in the glass tubing (marked by a felt pen on the outer wall of the glass tubing) during the administration of this POE to a mixed Grade 10-12 class of 18 students described in chapter 5.

Stimulate and challenge predictions according to students’ age and ability

Another consideration for designing POEs was to create situations where students were stimulated and challenged to predict according to their age and ability based on their personal reasoning. For example, the prediction reasons of a group of Grade 6-7 students when compared to those of a group of Grade 8-9 students obtained in a pilot study of the water-in-glass-tubing POE described in chapter 4 shows that their predictions were based on some personal reasoning, although their reasoned predictions were not as elaborate as those of the Grade 8-9 students.

Procedure for Administering POEs

Generally, students found that POEs involved the familiar task of answering direct worksheet-like questions. However, there are aspects of the direct questions that could be unusual that the teacher need to highlight. These aspects are described as follows:

Ensure that students understand the POE task.

It was an important first step in administering POE tasks to explain to students the nature of the situation about which they were being asked to make a prediction. For example, the water-in-glass-tubing POE equipment was placed in an elevated position for the whole class to view. The teacher then immersed the flask into a beaker of water (for the sake of explanation hot water was not used) and emphasised that one's eyes must immediately focus on the meniscus of the water level inside the glass tubing for few minutes. Then students in groups of five were in turn asked to have a close view of the water level being marked in felt pen on the outside wall of the glass tubing. Students were allowed to ask questions about the task before they proceed to their experiments in groups of two.

Insist on written responses and do not allow student to verbalise their ideas while making predictions and observations.

It was crucial that students write down their predictions and their prediction reasons on a teacher-prepared worksheet before making observations. This procedure forces students to commit themselves to decide what knowledge to apply and also no one would miss the observation because they were still writing or thinking. When the phenomenon to be observed occurred, all students were required to make independent observations and each described what they observed on the worksheet provided by the teacher. No discussion or communication of any kind was allowed. As shown by the results of the water-in-glass-tubing POE described earlier, there were variations in students' observations. If observations were not written at the time

they were made, some students would change their observational responses as a result of hearing what others claim to have seen.

Encourage reconciliation of any discrepancy between prediction and observation.

During the third step of the POE sequence where students would independently write down their reasons and explanations for any inconsistency between what they predict and what they observed, the teacher would encourage students to consider any possibilities they can think of. This was essential because students often found this step difficult and their ideas in this step often revealed further information for the teacher to interpret their understanding of science.

Monitor closely the discussion step (the last step) of the POE task.

This step provides the opportunity for students to discuss their work in groups of two or at most four. Most students were found to be looking forward to this experience because it was motivating for them to compare answers and argue their views. Their comments on each other's reasons and explanations provided the teacher/researcher with much insight into students' commitments on their understanding of the phenomenon and the way they discount contradictory observations.

Assure students that all responses are valued and respected.

The teacher provided a supportive discussion environment by discouraging teasing during the discussion step of the POE task and disrespectful students would face the consequence of being excluded from the discussion group. In many group discussions, students may lack self-confidence, may be discouraged from contributing by certain members or may lack the opportunity to express their views due to highly vocal members prolonged speeches. A conducive discussion environment allows students to reflect on the comments that they hear from others about their ideas, reasons and explanations just before they individually write down their final views on the phenomenon, their comments and their convictions on their

reasons and explanations. Students also were assured that the POE task is not a test so as to avoid them giving reasons and explanations to please the teacher. Instead their own views were requested.

Pilot Studies

The first pilot study was conducted to evaluate a POE on heat and expansion of water invented by the author in a practical lesson for 18 Grade 11 students. Students' written responses were used to interpret students' understanding of the phenomenon investigated (Liew & Treagust, 1995). Although one could account for students' responses to the POE experiment in terms of their poor observational skills, the data did demonstrate how students' prior knowledge and beliefs could affect their observation and interpretation of the phenomenon. However, variations in students' observations suggest that POEs need to be designed to produce 'on-the-spot', obvious and clear observation outcomes.

Subsequently, two more POEs were designed and trialed (Liew, 1996). A POE on the solubility of sugar was administered to three classes of Grade 9 students and a class of Grade 11 students. All 87 students experienced the same observation outcome. A POE on light globes was trialed on a class in each Grade level of 9, 11, and 12. All 41 students experienced the same observation outcome. Students' reasons and explanations were grouped into categories based on their similarities of wording and their use of distinctive words or concepts. The data revealed common existence of ideas and beliefs held by students that are often contrary to scientists' science. However, the POEs enabled students to demonstrate their science thinking and process skills. Specifically, students were able to articulate and experiment with their own ideas, make their own predictions, observations and explanations of phenomena. The results suggest that students have achieved part of the outcome in the 'Working Scientifically' substrand of the Student Outcome Statements. The results of these pilot studies also suggest the efficacy of well-designed POEs for sound data collection.

Ethical Issues

The following ethical issues were taken into consideration in the process of conducting this research:

- The school's administration required written consent on the basis of the teacher/researcher's intention to improve students' learning and teacher's teaching.
- Students' anonymity was guaranteed.
- The thesis, being a single-author report, may give rise to the danger of the researcher's interpretation masking the students' interpretation of their experiences. In order that the students' voice is heard (Brickhouse, 1991, p. 55) verbatim extracts of students' interview transcripts, and extracts of students' written POE responses were incorporated in the thesis.
- Individual students' written consent to participate in the study was obtained. Those not wishing to participate had the opportunity to learn by another teaching approach.
- Students and other participants were treated with honesty and respect rather than as means to the researcher's ends (Brickhouse, 1993).

Summary of Chapter 3

This chapter describes the interpretive action research methodology and the sample used in this study. The sample comprised students in classes from three Australian metropolitan high schools in Grades 9, 10, 11, and 12 whose age ranges between 14 and 17 years. To generate data for interpretation, three data collection methods were used, namely, written POE responses of students, in-class journals and student interviews. For data interpretation, three theoretical perspectives were used, namely, Chi et al.'s theory of ontological categories, Hewson and Hennessey's conceptual change theory to determine epistemological status of students' conceptions of science, and Chinn and Brewer's model to classify types of students' responses to contradictory data. The purpose of using the methodology was to obtain in-depth understanding, a plausible and credible account of students' understanding of science. Ethical issues that were related to the research were also discussed in this chapter.

CHAPTER 4

PILOT STUDY

Introduction

The purpose of this pilot study was to evaluate the effectiveness of POE tasks in providing information on students' understanding of science by taking into consideration design requirement and administration procedure described in chapter 3 (p. 10-11). Specifically, this study sought to answer Research Question 1: How effective is the Predict-Observe-Explain technique in diagnosing students' understanding of science across mixed grade classes?

The topics of heat and solubility were chosen because they were prevalent both in primary and secondary schools. Moreover, phenomena of heat and solubility were relevant to students' daily out-of-school experience even in an early age and it is likely that their experiences would form a basis of prior knowledge or beliefs. Three POEs were designed (water-in-glass-tubing, salt-in-water, salt-in-oil) and administered to a class of 18 Grade 11 students. The water-in-glass-tubing was also trialed on two mixed grade classes, namely, Grade 8-9 and Grade 6-7.

Trial of the Water-In-Glass POE Task

To evaluate the effectiveness of a POE in providing insights into 18 Grade 11 (age 16-17 years) students' understanding on heat and expansion of water, a POE involving the expansion of coloured water in glass tubing fitted to a round-bottom flask filled with coloured water was designed as shown in Figure 4.1. The experiment was conducted in groups of two students. When the flask is plunged into hot water, the level of the coloured water in the glass tubing first falls slightly and then starts to rise steadily. The initial fall in the level of the water is caused by the expansion of glass that becomes heated and expands before the heat has time to be conducted through the glass into the coloured water. The water level later rises as the liquid becomes heated and expands.

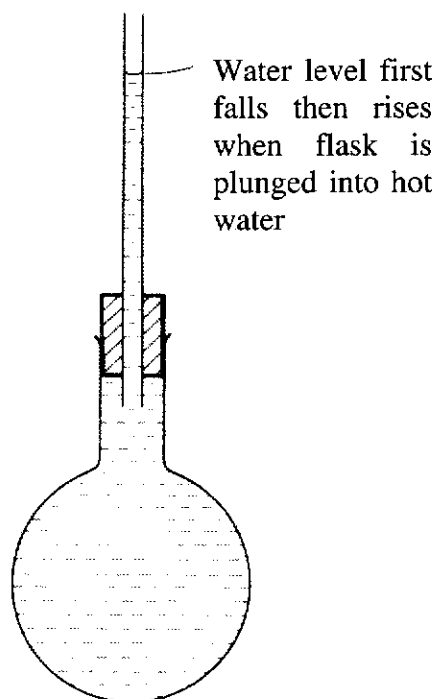

Figure 4.1 Water-in-glass-tubing POE

The instructional strategy

At the onset, students were told that they would perform an experiment and they were asked to predict what would happen and provide reasons for their predictions. The experiment was performed and students wrote down their predictions and observations.

Predict

The lesson began with the teacher/researcher showing the class some glass tubing fitted to a round-bottomed flask filled with coloured water. Students were told that this was not a test, and their views were requested on their explanation of this phenomenon. Subsequently, students were independently asked to write down their answers to the following question:

Predict what will happen to the water level in the glass tubing if the round bottomed flask is plunged into the hot water from the initial moment and onwards? State and explain the reason(s) for your prediction.

Observe and Explain

The next stage of the lesson sequence involved the students performing the experiment in nine groups of two. They were reminded that the Bunsen flame had to be removed as soon as the water in the beaker was boiled. The round-bottomed flask then was plunged into the beaker of hot water. The students were requested to independently write down their observations by answering the following question:

What happened to the water level in the glass tubing when the flask is immersed into the hot water from the initial moment and onwards? State and explain the reason(s) for your observations.

In the course of the experiment, students made independent observations while sharing the apparatus in groups of two and no discussions were allowed. In the next stage, students were asked to make comparison between their own prediction and their observations by answering the following question:

Compare your observation with your prediction. Are they in agreement or disagreement? Explain with your reason(s).

Finally, students within each group discussed their answers to the three questions after which they each wrote down their final reasons and explanations.

Results and discussion

Students' observations compared to their predictions about the level of water in the glass tubing are presented in Table 4.1. Of the 18 students, 2 predicted an initial drop, two predicted the water level would be unchanged, and 16 predicted an immediate rise. Of the 16 students who predicted a rise, 13 stated that they did observe an immediate rise. As it can be difficult to miss the initial fall of the liquid in

the glass tube, these findings may be due to students' poor observational skills. However, these grade 11 physics students were among the most able science students of their year. Consequently, from the researcher-teacher's perspective, the data suggest that these students' prior knowledge and beliefs, and hence their expectation of the outcome, influenced their observations. For example, as evidence of her strongly held beliefs influencing her observations, one student who predicted an immediate rise in the water level expressed that she already knew the outcome because of her former experiences with similar experiments, and her own reading in books.

Table 4.1. Prediction and observations of Grade 11 students on the change in water level (n=18)

	Number of student observations	
	Rise	Initial drop
Predict Rise	13	3
Initial drop	1	1
No change	0	0

Table 4.2. Students' reasons and explanations for predicted rise in water level in the glass tubing (n=16)

Reason	Explanation	
	Microscopic	Macroscopic
Water expands when heated (9)	Molecules move quicker (4) Molecules move faster and take up more space (1) No explanation (4)	
Water pressure increases (4)	Molecules more energetic and collide more frequently (1) Molecules move faster and further apart (1) No explanation (1)	Water pressure causes expansion (1)
No reason (3)	Particles move vigorously (1) Molecules move faster and further apart (1)	Water becoming cold (1)

Although students were not asked to explain their observations in any specific manner, many made use of their background knowledge and provided explanations in terms of molecules and their energy. Of these molecular explanations, only one of the 18 students gave a complete scientific explanation that water expands because molecules move faster and takes up more space (see Table 4.2). The majority of the 18 students seemed to hold incomplete, incorrect, or inconsistent links between the macroscopic concepts of liquid expansion and the microscopic concept of the kinetic theory of matter. Although one could account for students' responses to this POE in terms of poor observational skills, one argued that the data did demonstrate how students' prior knowledge and beliefs could affect their observations and interpretations of new learning. However, variations in students' observations suggest that POEs need to be designed to produce immediate, obvious and clear observation outcomes. Subsequently, two more POEs were designed and trialed.

The water-in-glass-tubing POE also was trialed on a group of 15 mixed grade (8 and 9) students (age between 13 and 14 years) and on another group of nine mixed grade (6 and 7) students (age between 11 and 12 years). The results of this trial are summarised in Tables 4.3 and 4.4.

Table 4.3. Prediction and observations about the change in water level for two groups of students (n=15, Grade 8-9 / n=9, Grade 6-7)

	Number of student observations		
	Rise	Initial Drop	Unchanged
Prediction			
Rise	2/4 ^a	11/3	0/2
Initial drop	0/0	2/0	0/0

Note a: Number of Grade 8-9/number of Grade 6-7

Table 4.4. Students' reasons for predicting a rise in water level for two groups of students (n=15, Grade 8-9/n=9, Grade 6-7)

Grade 8-9	Grade 6-7
Heat pushed water level higher (6)	Pressure in the flask (2)
Hot water/steam (4)	Heat (3)
Water in flask got hotter (2)	Hot water (4)
Water expands (1)	
Heat evaporates water (2)	

Table 4.4 shows the prediction reasons of the Grade 6-7 student group used to explain the observed rise aspect of the POE experiment by all nine students. The initial drop of water level in the glass tubing was clearly observed by the teacher/researcher (who was with them during the experiment) but was not observed by 6 students (4 observed a rise and 2 claimed it was unchanged-see Table 4.3). During class discussion, each of the six students said they did not observe an initial drop. This could be due to their lack of observational skills. The three students who did observe an initial drop in the water level although provided an explanation each for the later observed rise did not explain the observed initial drop. During class discussion, none in the class was able to explain the initial drop in water level. This was in contrast to the Grade 8-9 students where 11 out of 15 students were able to observe the initial drop in water level. The Grade 8-9 students' better observational skills could be due to a higher emphasis of observational skills training in the Grade 8 science curriculum. The results point to the need to design POEs that takes into account poor observational skills of students. It cannot be assumed that all will see the same observation outcome. Additionally, the data point to the fact that Grade 6-7 student predictions were based on some personal reasoning, although not as elaborate as the Grade 8-9 students (see Table 4.4) and were not a result of guessing.

Trial of the Salt-In-Water and Salt-In-Oil POE Tasks

To collect data on a group of Grade-11 students' ideas and beliefs on solubility a POE task for salt and water was designed as follows:

1. Prediction/Explanation before the experiment

Predict what will happen to a teaspoon of table salt if it is dropped into a cup of water and stirred. State and explain the reason(s) for your prediction.

2. Observation/Explanation during the experiment.

Describe what happens to a teaspoon of table salt if it is dropped into a cup of water and stirred. State and explain the reason(s) for your observation.

3. Comparison of prediction and observation after the experiment.

Compare your observation with your prediction. Are they in agreement or disagreement? Explain with your reason(s).

4. Group discussion on their answers to the above three questions and writing down their final reasons and explanations.

A second Predict-Observe-Explain learning sequence was also performed using a different solvent (cooking oil) for salt. The salt/water and salt/cooking oil situations were chosen because they were relevant to the daily out-of-school experiences. Students would have similar experiences at home in their parents' kitchen.

Results and discussion for Salt-in-Water POE

All the nine Grade-11 students predicted and observed the 'disappearance' of salt in water. Their explanations were as follows:

salt is dissociated (1)

salts atoms/molecules are dissociated into sodium ions and chloride ions (2)

salt ions are dissociated by water molecules (2)

salt ions combine with water molecules (2)

salt become ions surrounded by water molecules (2)

Students' view of the solubility phenomenon was based on their sensory experience of salt having the property of becoming invisible in water, which tend to focus on the solute (salt). Similar findings also were reported by Prieto, Blanco, and Rodriguez (1989) where students focus on the solute whilst assuming the 'passive role' for the solvent. However, two students were able to provide an explanation (salt ions are dissociated by water molecules) that is related to scientists' view of solubility.

Results and Discussion for Salt-in-Oil POE task

Students' reasons for their predictions and observations were listed and grouped into categories based on their similarities of wording and their use of distinctive words or concepts. Results of the predictions and observations of the class of nine Grade-11 students are given in Table 4.5.

Table 4.5. Predictions and observations of grade-11 students (n=9)

		Predicted		
		Soluble	Insoluble	Don't Know
Observed	Soluble			
	Insoluble	4	3	1
	Slightly Soluble	1	0	0

The four students who predicted the solubility but observed the insolubility of salt in cooking oil provided the following prediction reasons:

1. Salt ionises and mixed with oil to form a solution (1)
2. Salt dissolves in oil (2)
3. Salt molecules join onto the hydrocarbon chain of oil (1)

Their observation reasons are as follows:

1. Oil does not dissolve salt (3)
2. Oil is not a solvent (1)

The four students could have derived their reasons from the previous salt-in-water POE experience. Their predictions and reasons were influenced by their prior experience and learning. When their prediction is contradicted by their observation of the insolubility of salt in oil, active reconstruction of explanations occurs. For these four students, their contradictory experience drew their attention to the problem and created an opportunity for reconstructing their view. Their reconstructed view suggests a way they perceived the nature of the solubility phenomenon, namely, solubility as a property of the solvent. That is, 'oil does not dissolve salt' or 'oil is not a solvent'.

A student who predicted the solubility and observed the slight solubility of salt in oil gave his prediction reason as 'oil contains water'. His observation reason was 'oil has a small amount of water so a small portion of salt was dissolved'. The student's prediction and observation is influenced by his prior knowledge, reason and, expectation learned during the salt-in-water POE and from other previous occasions. Although the salt-in-oil POE was designed to provide an immediate, obvious and clear observation outcome (8 out of 9 students observed the insolubility of salt in oil), he tended to observe or focus on the aspect of the experiment that supported his prior or pre-conceived reason and expectation. He tended to see what he wanted to see during the experiment. This variation in student observations suggests that uniform observation outcome of a well designed POE cannot be always assumed by the designer. However, the data does suggest that a well-designed POE intended to produce immediate, obvious and clear observation outcome does reduce variation in students' observation. Furthermore, the data also suggest the effectiveness of POE in an open-ended format (without giving a choice of possible responses) in capturing a range of possible students' observation and prediction outcomes.

The student who was unable to make a prediction but observed the insolubility gave his observational reason as 'oil and water did not mix physically or chemically'. This student's understanding is associated with the miscibility property of different substances.

The three students who predicted and observed the insolubility of salt in oil provided the following prediction reasons:

1. salt remain as crystal (1)
2. ionic substance (salt) only dissolve in water to form ions (1)
3. oil is not a good solvent (1)

Their observation reasons are:

1. organic substances (oil) do not dissociate ionic substances into their component ion (1)
2. no bond breaking by oil/ salt remain as solid (1)
3. oil cannot dissociate the ions of salt (1)

Students viewed the solubility phenomenon as a property of substances. Examples are: 'oil is not a good solvent', 'oil don't dissolve salt', and 'ionic substances dissolve only in water'. Students also viewed the solubility phenomenon as a process of interaction between salt and oil using the particle model. Examples are: 'oil cannot dissociate the ions of salt' and 'no bond breaking by oil'. The scientist's explanation of solubility is that it is a process of interaction of the electrostatic attractive forces between the particles (molecules, atoms, ions) of the solute and the particles of the solvent. Specifically, the electrostatic attractive forces between solute particles must be overcome by the larger attractive forces between solute and solvent particles (Anderton, Garnett, Liddelow, Lowe & Manno, 1996, p. 210). The underlying meaning that the students have for the words (dissociate and bond breaking) they used to explain the dissolving process is not elaborated. Hence, to what extent are students' views consistent with those of scientists' is unclear. However, the data suggest that students do have an incomplete particle model view of the dissolving process indicated by their use of words like 'ions of salt', and 'component ions' to describe the form of the solute.

Summary of Chapter 4

The POE tasks on expansion of water and solubility of salt produced data that demonstrated how students' prior knowledge affected their prediction, observation and interpretation of phenomena. Variations in students' observations suggest that uniform observation outcome may not be always assumed even for a well-designed POE intended to provide an immediate, obvious, and clear observation outcome. The data also suggest that POE tasks are effective in capturing a range of possible student observations and prediction outcomes when worded in an open-ended format.

The efficacy of POEs in diagnosing students' understanding of science was demonstrated in this pilot study. Research question 1, which sought to evaluate the effectiveness of POE tasks in diagnosing students' understanding of science across grade levels and across mixed grade classes, was answered. Specifically, students' ideas diagnosed were common across grades, across mixed grade classes and were largely inconsistent with those of scientists.

The results of the water-in-glass-tubing POE led the researcher to alert students to focus their attention on the meniscus of the water in the glass tubing (marked by a felt pen on the outer wall of the glass tubing) during the administration of this POE to a mixed Grade 10-12 level class of 18 students described in chapter 5. Moreover, these data suggest that the water-in-glass-tubing POE would be within the ability of most students at Grade 10-12 to make reasoned predictions and hence would provide credible data for the teacher/researcher to interpret students' responses to anomalous observations discussed in the next results chapter.

CHAPTER 5

RESULTS OF THE WATER-IN-GLASS TUBING POE TASK

Introduction

In Chapter 4, data produced using POE tasks on expansion of water and solubility demonstrated how students' prior knowledge affected their prediction, observation and interpretation of science phenomena. The purpose of this chapter is to evaluate the effectiveness of POE tasks in diagnosing how students respond to contradictory observations. Specifically, this part of the study sought to answer Research Question 2: How effective are POE tasks in diagnosing types of students' responses to contradictory observations?

A framework for diagnosing and understanding students' responses to POE tasks was adapted from Chinn and Brewer (1993; 1998) who argued that understanding how students respond to contradictory information, which is typical of many POE phenomena, was essential to understanding students' science in the classroom. Their argument was based on two reasons: contradictory information in science lessons is very commonly experienced and, typically, students prefer to retain rather than change their pre-instructional theories and beliefs even in the face of contradictory evidence. To account for how students would respond to anomalous information, Chinn and Brewer postulated eight types whereby students (i) ignore data, (ii) reject data, (iii) exclude data, (iv) hold ideas in abeyance, (v) express uncertainty of data, (vi) accepting data by reinterpreting, (vii) accept data by modifying an existing theory and (viii) accept data by changing core beliefs of a current theory or turn to an alternative theory.

The Water-In-Glass-Tubing POE Task

To evaluate the effectiveness of a POE in providing information into students' understanding of heat and the expansion of water, an experiment was carried out involving the expansion of coloured water in a glass tubing fitted to glass flask/bottle filled with coloured water as shown in Figure 4.1 on page 2 of Chapter 4

Heat and expansion of water was chosen because it is a topic that is prevalent in both primary and secondary school. Also heat is experienced by students at a very early age, and it is likely that experience with situations involving heat and expansion form the basis of prior knowledge or beliefs.

At the onset, students were told that they would perform an experiment and they were asked to predict what would happen and provide reasons for their predictions. The experiment was performed and students wrote down their predictions and observations.

Predict

The lesson began with the teacher/researcher showing the class some glass tubing fitted to a round-bottomed flask filled with coloured water. Students were told that this was not a test, and their views were requested on their explanation of this phenomenon. Subsequently, students were independently asked to write down their answers to the following question:

Predict what will happen to the water level in the glass tubing if the round bottomed flask is plunged into the hot water from the initial moment and onwards? State and explain the reason(s) for your prediction.

Observe and Explain

The next stage of the lesson sequence involved the students performing the experiment in nine groups of two. To reduce the influence of students' poor observation skills on their POE responses, students were not allowed to boil their own hot water using the Bunsen flame. Instead student groups were required to collect boiling water from the teacher/researcher. Additionally, students were instructed to focus their eyes on the marked part of the glass tubing, where the meniscus of the water level was, the moment the glass flask/bottle was immersed into the hot water. The round-bottomed flask then was plunged into the beaker of hot

water. The students were requested to independently write down their observations by answering the following question:

What happened to the water level in the glass tubing when the flask is immersed into the hot water from the initial moment and onwards? State and explain the reason(s) for your observations.

In the course of the experiment, students made independent observations while sharing the apparatus in groups of two and no discussions were allowed. Next, students were asked to make comparisons between their own predictions and their observations by answering the following question:

Compare your observation with your prediction. Are they in agreement or disagreement? Explain with your reason(s).

Finally, students within each group discussed their answers to the three questions after which they each wrote down their final reasons and explanations.

Results of Water-In-Glass-Tubing POE Task

The water-in-glass tubing POE was administered to a mixed year class (Grade 10 to 12) of 18 students. Students worked in groups of two with very close supervision of the teacher/researcher who observed student groups with lesser observation and practical skills. Students' observations compared to their predictions about the level of water in the glass tubing are presented in Tables 5.1 and 5.2.

Table 5.1. Prediction and observations about the change in water level
(n=18, Grade 10-12)

Prediction	Number of student observations	
	Rise	Initial drop
Rise	8	10
Initial drop	0	0

Table 5.2. Students' reasons and explanations for predicted rise in the water level
(n=18, Grade 10-12)

Reason	Explanation	
	Microscopic	Macroscopic
Water expands when heated (5)	Molecules move quicker and further apart (1) Molecules move faster (3) Heat molecules entered in (1)	
Heat (10)	Molecules move faster and need more room (1) Molecules expand (1) Molecules move faster (2) No explanation (5)	Air in water expands (1)
Water pressure increases (2)	Molecules hitting side of flask (1)	Pressure causes water level to rise (1)
Water boils (1)		Water bubbles (1)

Table 5.1 shows the prediction reasons and explanations of the group of mixed Grade (10-12) students used to explain the observed rise aspect of the POE experiment by all 18 students. Although students were not asked to explain their observations in any specific manner, many made use of their background knowledge and provided explanations in terms of molecules and their energy. Of these molecular explanations, only one of the 18 students gave a complete scientific explanation that water expands because molecules move faster and takes up more space (see Table 5.2). The majority of the 18 students seemed to hold incomplete, incorrect, or inconsistent links between the macroscopic concepts of liquid expansion and the microscopic concept of the kinetic theory of matter.

The data suggest those students' prior knowledge and beliefs and hence their expectation of the outcome, influenced their prediction and even the observation of some as is evidenced by the data given in Table 5.1. Four out of eight students in the mixed year student group who recorded a rise in water level acknowledged (in their interview and in-class journal) that they actually did see an initial drop as well. The other four students had their observations affected by a faulty experimental procedure (a delayed immersion of the glass bottle). It should be noted that the initial drop in water level, although less obvious, was still noticeable by the teacher/researcher who was with them. After repeating their experiment following the proper procedure, students observed the initial drop in water level and wrote down reasons for their observations.

Data Analysis and Interpretation

Tables 5.3 and 5.4 present a summary of the results of the analysis of the data of the class of 18 mixed year students using the framework adapted from Chinn and Brewer (1993, 1998). When students' responses did not fit the categories of Chinn and Brewer, new or modified categories were created to interpret the data. Table 5.4 presents types of students' responses and features for each response. Table 5.5 shows the influencing factors on students' responses.

Table 5.3. Features of each of the responses to anomalous observations (n=18)

Type of response	Features of the response		
	Does the student accept the data?	Does the student explain the data?	Does the student change theory?
A. Considering observations irrelevant: Ignore and/or reject data (5) (Briony, Sheila, Amy Simona, and Demelza)	No	No	No
B. Excluding data as it does not fit one's theory (2) (Dan B and Bobby)	Yes	No	No
C. Accepting new data but unable to explain the phenomenon using a scientist's conception (9)			
1. Reinterpret (4) (Harmony, Becky, Sian and Venetia)	Yes	Yes but wrong	Yes/modified
2. Acknowledge impasse/unable to explain in any way(5) (Christian, Nat, Nicole, Kama and Sharni)	Yes	No	No
D. Accepting new data and explain the phenomenon using a scientist's conception (2) (Kerwin and Dan M.)	Yes	Yes	Yes

Table 5.4. Types of responses of the mixed Grade 10-12 class (n=18)

Type of students' responses	Influencing factors
A. Considering observations irrelevant: Ignoring and/or rejecting data (5) (Briony, Sheila, Simona, Amy and Demelza)	<ol style="list-style-type: none"> 1. Characteristic of the data: Lacked credibility/perceived experimental error (5) 2. Epistemological commitment: Confirming-evidence-seeking/ Prediction fulfilling (5)
B. Excluding data as it does not fit one's theory (2) (Dan B. and Bobby)	<ol style="list-style-type: none"> 1. Epistemological commitment: Confirming-evidence-seeking/ Prediction fulfilling (2)
C. Accepting new data but unable to explain using a scientist's conception (9)	
<ol style="list-style-type: none"> 1. Reinterpreting (4) (Harmony, Becky, Sian and Venetia) 	<ol style="list-style-type: none"> 1. Characteristic of the data: Credible/clearly observed (4) 2. Characteristic of a new theory: Available through personal construction of a modified but incorrect theory (4) 3. Epistemological commitment: Confirming/disconfirming-evidence-seeking (3) Confirming-evidence-seeking (1)
<ol style="list-style-type: none"> 2. Acknowledging inability to provide any explanation (impasse)(5) (Christian, Nat, Nicole, Kama and Sharni) 	<ol style="list-style-type: none"> 1. Characteristic of the data: Credible/clearly observed (5) 2. Epistemological commitment: Confirming-evidence-seeking (2) Confirming/disconfirming-evidence-seeking (1) Neither (2)
D. Accepting new data and explain the phenomenon using a scientist's conception (2) (Kerwin and Dan M)	<ol style="list-style-type: none"> 1. Characteristic of the data: Credible/Clearly observed (2) 2. Characteristic of a new theory: Availability of a correct theory (2) 3. Epistemological commitment: Confirming/disconfirming-evidence-seeking (2)

The organisation of this report on students' responses was grounded using data sources which included students' written POE responses, in-class journal and interview excerpts. Descriptors and criteria for classifying students into categories of

responses to contradictory observations adapted from Chinn and Brewer (1993) were used as a guide. Factors related to categories were identified from students' descriptions and explanations for their observations, comments they made about their own observations and explanations and, convictions of their comments and explanations reflected by their language (phrases and expressions).

A. Considering observations irrelevant: Ignoring and/or rejecting data

Excerpts from interview transcripts and in-class journals of two students were analysed and categorised as 'Considering observations irrelevant'. The analysis of the first response, Briony, who was a Grade 10 student, proceeded as follows:

Interview excerpt: I did see it went down slightly, but I didn't think that it was important. Because I thought we could have done something wrong... I don't know, maybe due to some error in carrying out the procedure. Anyway, it [the initial drop] was obvious.

In-class journal: I did observe the slight drop in the water level, but I wasn't sure if I had actually seen anything. I didn't think it was obvious or important, so I neglected to write it down. I thought that maybe we had made some mistake, which had caused the water level to drop and that it wasn't meant to. I did see the rise and I thought that was the important part.

The above data from Briony, using descriptors of Chinn and Brewer (1993, page 4-6), showed that she responded to the phenomenon in two ways. Firstly, she ignored an aspect of her observation of the phenomenon that she didn't think was important or relevant. Secondly, she also rejected that aspect of her observation by arguing that her group may have committed 'some error in carrying out the experimental procedure'. Chinn and Brewer would describe this ground for rejecting the observation as 'methodological error' and the perceived experimental error provided data that lack credibility. This characteristic of the data served as an influencing factor for rejecting the observation. Moreover, Briony was inclined to focus her observation on that aspect of the experiment ('I did see the rise and I thought that was the important part') that supported her prediction outcome. Influenced by her expectation of the outcome, she interpreted the unimportant initial drop in water level as being a result of faulty experimental procedure, thus ignoring and rejecting the anomalous data without even making an attempt to account for the source and nature of the perceived experimental error.

An analysis of the second student, Sheila (Grade 10), proceeded as follows:

In-class journal excerpt: What were your reactions and thoughts when you observed the drop in the water level? Why?

When I saw the water level drop I didn't think much of it. I thought at first that maybe we had bumped the container and that the water was not really supposed to go down. So when writing my observation I dismissed the "idea" even though it really was supposed to go down.

Sheila initially ignored ('I didn't think much of it') her observed initial drop in water level without even explaining away the unexpected prediction outcome. She was expecting only a rise in water level ('the water was not really supposed to go down'). On reflecting, Sheila, later even rejected ('So when writing my observation I dismissed the idea') this aspect of her observation on the ground of perceived procedural error ('maybe we had bumped the container').

Both Sheila and Briony demonstrated a prediction-fulfilling epistemological commitment, which served as the factor that caused each of them to ignore a contradictory observation that they considered to be irrelevant. They even rejected the contradictory data (the initial drop in water level) on the ground of perceived procedural error. Their epistemology also has a confirming-evidence-seeking characteristic which hindered their new learning: of the obvious initial drop in water level aspect of the observation and a possible constructing of interpretation (the glass bottle expanded before the heat could reach the water inside it) to account for the phenomenon. Their epistemological commitment was essentially to seek confirming evidence to justify their prediction. These students' data suggested that unexpected phenomena or anomalous data (using Chinn and Brewer's descriptors) that contradict one's epistemological commitment are ignored or rejected in order to produce their prediction-fulfilling responses.

Like Briony and Sheila, inconsistent data presented in this POE also was perceived as due to experimental error by Simona (Grade 10) whose data analysis proceeded as follows:

In-class journal excerpt: What were your reactions and thoughts when you observed the drop in water level? Why?

When I saw the drop in water level, it shocked me and straight away I thought that my prediction was wrong. But when it started to rise then I was relieved because I knew my observation was a bit in line with my prediction. So really my thoughts were up and down during the experiment. Also when I saw it drop, I thought I did the experiment wrong.

The inconsistent data led Simona to reflect on the accuracy of her prediction. She explained the anomalous data as one that was due to procedural error in carrying out the experiment. When evidence (the subsequent rise in water level) that supported her prediction was observed, her prediction-fulfilling commitment was expressed ('I was relieved'). It could be inferred that Simona's, like Briony and Sheila, prediction-fulfilling commitment predisposed her to ignore a contradictory observation. She even rejected the observation on the ground of perceived procedural error in the experiment.

While Simona, Briony and Sheila rejected a contradictory observation on the ground of perceived procedural error in the experiment, two students' (Demelza and Amy) observations actually were affected by a faulty experimental procedure (a delayed immersion of the flask into the hot water). It should be noted that the initial drop in water level, although less obvious, was still noticeable (as observed by the teacher/researcher who was with them). The analysis of the data of Demelza and Amy (in-class journal, interview and POE responses), who repeated the experiment as a group, proceeded as follows:

Demelza (Grade 10)

Prediction response: I think the green water will rise further out of the tube when plunged into the hot water.

Observation response: The water did as I predicted, because of the air warming up (molecules moving faster), the air pushes the water up the tube. As the air cooled it moved back down the tube.

In-class journal: What were your reactions and thoughts when you observed the drop in water level? Why? I didn't observe a drop in water level. I predicted a rise. I observed an almost immediate rise, I had predicted as much so I wasn't all that shocked or surprised. The water rose slower than I had originally thought, heated up

slower than expected. Later when I found out that the water was supposed to drop first, I was very surprised.

Amy (Grade 12)

Prediction response: The water level will rise because the heat will force the cold water further away. I don't know why I think this.

Observation response: When we completed the experiment we observed that the water rose slowly. When interviewed Amy stated that '...It stayed for a while before it goes up.' I think that this happened because the molecules speed up when they are heated, they could not expand so they had to move up.

In-class journal: My reactions and thoughts when I saw the drop in the water level were different with both experiments. The first time I did the experiment I did not notice the drop in the water level so it didn't bother me, but the second time when the drop in the water level was pointed out to me I wasn't all that overwhelmed, happy or anything because how are we supposed to react to a science experiment. It is not something that I get excited about when I realize the water level in the glass has dropped before my eyes.

Demelza did not only observe an immediate rise in water level but was also expecting a higher rate of the rise ('The water rose slower than I originally thought, heated up much slower than expected.') in her first experiment. Her prior knowledge influenced her expectation of the observation outcome in her first experiment, even to the point of being surprised by the observed initial drop in the second experiment. However, Amy, due to her prior knowledge, was expecting and subsequently observed a rise in water level in her first experiment. She was unaffected by her observed initial drop in water level in her second experiment. Both students ignored the contradictory data and provided no explanation for their unexpected observation. Neither Demelza nor Amy sought any disconfirming evidence (contradictory observation) for their prediction.

The above analysis of the responses from Amy and Demelza suggest that an actual faulty experimental procedure in carrying the POE can result in observation difficulty for students who may be lacking in observational skills. Therefore, such students would need 'desk' supervision (teacher/researcher working with them at their bench) to remind them of the need for immediate immersion of the glass flask into hot water collected from the teacher. Alternatively, the teacher may conduct a demonstration of the POE at the students' bench. Nevertheless, the data still revealed that students were more likely to seek confirming evidence (observation that is

consistent with prediction), which influenced them to ignore the contradictory observation.

A concluding inference that could be made from the data analysis of Briony, Sheila, Simona, Amy and Demelza was that they all responded to their contradictory observation (the initial drop in water level) by considering it irrelevant. Consequently, they ignored and/or even rejected their observation. Their responses were influenced by two factors. First, their epistemological commitment had the characteristics of confirming-evidence-seeking (the observed rise in water level that fitted their prediction expectation) and prediction fulfilling (making the right prediction). Second, the contradictory observation itself lacked credibility, which was due to perceived experimental error.

B. Excluding data as it does not fit one's theory

Data analysis using journal excerpts of two students, Dan B. and Bobby who indicated a prediction-fulfilling epistemological commitment but responded to anomalous observation by exclusion, proceeded as follows:

Dan B. (Grade 10)

In-class journal excerpt: I thought I had made a wrong prediction at first, when I saw the water level stayed still. After a while it started to rise, and I got so excited because I was right! Eventually, the water level rose so high it started to come out of the top of the glass tube.

Bobby (Grade 11)

In-class journal: I observed an immediate rise. I thought that the water level would have risen faster because I thought the reaction time to the hot water would have happened faster. So I was surprised.

Although the contradictory data of unchanged water level did elicit Dan B. to think about the accuracy of his prediction ('I thought I had made a wrong prediction at first'), he was not committed to account for it. Instead, he responded to the subsequent rise in water level with excitement; thus demonstrating his prediction-fulfilling epistemological commitment ('I got excited because I was right'), which is also characterised by a confirming-evidence-seeking focus (After a while it started to rise...).

Similarly, Bobby, who recorded an observed immediate rise in water level responded with surprise, was expecting a faster rise. Subsequently, when interviewed by the teacher/researcher, Bobby, whose partner was Dan B., acknowledged that he did see the initial drop in water level but did not write it down. He did not account for the contradicting data. Instead, he only accounted for the observed rise ('...the water in the glass will get hot..., the heat in the boiling water got into the water in the glass...') in his POE response sheet. Like Dan B., Bobby was also demonstrating a prediction-fulfilling and confirming-evidence-seeking epistemological commitment.

It could be inferred from the data that Dan, and Bobby's prediction explanations, expectations and commitments were not intended to account for the contradictory data. Consequently, the data were excluded, as they neither fit their theory nor their epistemological commitment.

C. Accepting new data but unable to explain the phenomenon using a scientist's conception.

The following section describes the analysis of responses of nine students who accepted anomalous observations but were unable to explain using a scientist's conception. Among the nine students, two (Becky and Harmony) had their observations affected by faulty experimental procedure (a delayed immersion of the flask into the hot water). It should be noted that the initial drop in water level, although less obvious, was still noticeable (as observed by the teacher/researcher who was supervising them).

1. Reinterpreting the data

In her response to question 4 of the POE response sheet, Becky (Grade 11) wrote:

We both came to the conclusion that when room temperature water is heated the water molecules move/vibrate faster, therefore, this causes the water to rise. Before it rose up it fell down slightly. This happened the second time (she repeated her group experiment with the teacher) that we did the experiment and I believe I missed it the first time because I was not expecting it to do that. I believe this happened because of the shock to the molecules they were stunned and were not moving as fast as what they were normally.

In-class journal: I did not notice a drop in the water level the first time but the second time I did. ...Now I can remember doing a similar task at my old school but only remember the water rising.

The above in-class excerpt and POE response of Becky suggest that her prior knowledge, belief (due to her experience with a similar experiment in her former school) and hence her expectation of the prediction outcome influenced her observation. When observing, she tended to seek confirming evidence (the rise in water level) that supported her prediction. Becky could articulate an explanation for why the contradictory data should be rejected ('...I missed it the first time because I was not expecting it to do that'; '...doing a similar task at my old school but only remember the water rising.'). In her second experiment, however, she accepted the contradictory observation (the initial drop in water level) and incorrectly accounted for it ('...they [molecules] were stunned and not moving as fast as what they were normally.').

Similarly, Harmony (Becky's partner), a Grade-11 student, responded to the second experiment as indicated in the following data:

In-class journal: Originally when I did the experiment I didn't notice the drop in water level, but when I did the experiment the second time I did notice the drop.
Additional response to question 4 of the POE sheet:

I realise that the water level fell before it rose. I think that this happened because the water molecules were adjusting and froze (stayed still) in the process.

Harmony, whose explanation for an observed immediate rise during the first experiment was 'water particles begin to move faster and so need more room' reinterpreted the observed initial drop in water level in the second experiment by explaining that 'water molecules were adjusting and froze (stayed still) in the process'. The credibility of the anomalous data, which she clearly observed, influenced Harmony to modify her theory of expansion of water. She explained both aspects of her observation (the initial drop and the subsequent rise in water level) instead of just seeking confirming evidence that supported her prediction. Harmony accepted the contradictory observation but was unable to account for it in an acceptable scientific way.

The following is an analysis of data from two students who also accepted the contradictory observation but were unable to explain the phenomenon using a scientist's conception:

Sian (Grade 11)

Her prediction response: I predict that the water in the glass tubing will rise. I think this will happen because the water in the flask will heat in the hot water causing the water molecules to expand and therefore rise in the glass tubing. It may even flow over, out of the glass tubing.

Her observation response: From the initial moment the glass flask was put in to the container I observed that the water lowered in the tubing and then after a short amount of time the water started to rise and continued to do so until it was removed. The reason I believe this happen is because the hot water caused the cold water molecules to contract & as soon as the cold water began to warm the molecules expanded.

Her prediction/observation comparison response: My observation and my prediction were very similar except I was not expecting the water to recontract down in to the tube. I was just expecting it to rise.

Group discussion response: Our group thinks that the rising and falling of the water has some thing to do with the fact that hot molecules move faster than cold molecules; they also hit the side of the glass-tubing faster and build up more speed and pressure.

Her prior knowledge indicated in her prediction response and expectation of the outcome ('I was expecting it to rise, ...I was not expecting the water to recontract down...') did not influence her observation. Moreover, she used 'her squashy molecule model' to explain the observed initial drop (molecules contracted) and the subsequent rise in water level (molecules expanded). She holds macroscopic notions of molecules and assumes that a single molecule (see Andersson, 1990) carries the properties of the substance (e.g. can expand, is malleable). Instead of ignoring or rejecting the anomalous data, she was able to use her prior knowledge and personally constructed theory to explain her observation. Neither her prior knowledge influenced her observation nor was she only looking for confirming evidence to fit her prediction.

Likewise, an analysis of data from Venetia (Grade 10), who accepted the anomalous data with incorrect explanation, proceeded as follows:

Prediction response: I think that when the flask is first placed in the hot water that the water level in the glass tubing will rise, but when the hot water cools the water level will drop slowly back down. I think this will happen because when the molecules in the water are heated they move rapidly and create more pressure. When this happens the only way for the water to expand and release the pressure is for the water to rise up the glass tubing as the heat and pressure drops, so does the water level.

Observation response: When it was placed in the water, the water level dropped at first for a second, but then the water level started rising. I think it dropped at first because there was greater pressure in the hot water than [than] there was in the flask so they [the] pressure inside dropped for a second, but as the water in the flask got hotter the molecules moved faster so the pressure increased resulting in the water rising up the glass tubing.

In-class journal: When the water level dropped I was actually a bit shocked as it happened. My thoughts, when it occurred were that, Why did it happen? My reason for being shocked was because I hadn't thought at all that it would happen, and at that time I didn't know why it happened either.

Venetia accepted the anomalous data and also constructed her own explanation for her observation of the initial drop in water level using an incorrect reduced-pressure theory. This is a modification of her pressure-increase-with-temperature theory, which was used to account for the subsequent rise in water level. Although she sought confirming evidence as indicated in her question 2 (...but then the water level starting rising.) and her question 3 (They [prediction and observation] are in general agreement...) responses, Venetia's in-class journal (...hadn't thought at all that it would happen, and at that time I didn't know why it happened either.) response suggested that she accepted the unexpected data but was unable to correctly account for it. Moreover, her case is an instance of seeking both confirming and disconfirming evidence for her prediction.

2. Acknowledging inability to provide any explanation

The following is a description of the analysis of data from five students who acknowledged their inability to account for their contradictory observation. Unlike Becky and Harmony, however, these five students could not provide any explanation, right or wrong, for their contradictory observation.

The first student was Christian (Grade 12) who responded to the contradictory aspect of the new data by looking for confirming evidence (...but then it rose...) that is consistent with his prediction explanation and expectation to justify his knowledge claim. This is evidenced in question 2 of his POE response sheet: 'At first it went down a bit but then it rose about 2 inches. This is because the level will rise higher. This will happen because the temperature outside the glass tubing will cause the temperature of the water inside the tube to rise. Therefore, the water will rise.'

However, the observed initial drop in water level led Christian to reflect on the accuracy of his prediction which was indicated in his in-class journal: 'I thought that what I had predicted was incorrect which baffled me. Then I saw it start to rise and that baffled me even more. I could [not] figure out why.' Although, the contradictory information did not initiate a theory change, the unexplainable data did produce an impasse: a problem that he could not solve, either correctly or incorrectly. Christian's reflection on his current knowledge and his inability to completely explain the observed data elicited a conflict in his thinking: inconsistency between his current theory and the known data ('...what I had predicted was incorrect which baffled me...'). He accepted the new contradictory data but was unable to come up with an immediate explanation, experiencing an impasse (Chinn and Brewer, 1998, p. 102).

Similarly, Nat, a Grade 11 student, revealed her inability to account for the contradictory observation as indicated by the following excerpt of her in-class journal:

When I saw the water level go down, I thought I was wrong and I was surprised that it did that. I hadn't expected it to do that. I don't know why it did that, but I didn't pay much attention to it, because I got the rest of the experiment right.

Although Nat accepted the anomalous data (water level goes down), she could not explain the contradictory observation. She was more interested in looking for that aspect of her observation that supported her prediction. The impasse (the problem that cannot be solved) Nat experienced did not elicit a commitment for an alternative explanation.

While Christian and Nat did not show a commitment to explain their contradictory observation, Nicole (Grade 12) did as indicated in the following data analysis:

Nicole (Grade 12)

Prediction response: I think that if the flask is placed in hot water, the water level will rise. This is because the pressure on the outside of the flask is greater than the pressure on the inside of the flask, so the water on the inside of the flask is forced out of the tube. Scientifically, this is [caused by] water molecules hitting the sides of the flask at different speeds.

Observation response: From the initial moment, the water went down approximately 1 cm and then it rose slowly and kept rising. This is because the pressure on the outside of the flask is greater than the pressure on the inside of the flask, so the water on the inside of the flask is forced out of the tube.

In-class journal: What were your reaction and thoughts when you observed the drop in the water level? Why?

When I first noticed the drop in the water level, I was surprised because I didn't expect such a thing to happen in this particular experiment, but then I became perplexed as to why it happened. I thought I knew why the water rose, but I had no idea in the world why it went down. Not knowing the answer to this reaction was very frustrating and I became determined to find out why it did what it did.

Nicole accepted the anomalous data that she could not explain and she did not stop to think about the reason for the drop in water level. Although, she did explain somewhat incorrectly the subsequent rise in water level, she was not content with this correct part of her prediction by seeking only the confirming evidence. Instead she acknowledged her own inability to explain her observed initial drop in water level and was determined to find a reason for her observation.

While Christian, Nat and Nicole acknowledged their inability to account for the contradictory observation, Kama (Grade 10) was even more explicit in expressing her inadequacy to account for her observation, as is revealed in the following analysis of her responses.

Prediction response: I don't think that anything will happen to the water level. I am not really sure, but when you plunge something cold into something hot, it becomes warm, or if it is ice it will melt. I don't think it will make a difference to the water level, because it is not adding water into it, it is on the outside of the flask.

Observation response: The water level went up when it was immersed in water. It went down and went up, and kept going, until it went over the tube. I think the

molecules got heated so they got faster and pushed the water out. I don't know why this happens, and I am not sure that I am right.

Question 3 response: My prediction [unchanged] is in disagreement with my observation [initial drop]. I really didn't know what was going to happen or why. Even in my observation I am not sure why it did what it did. I thought it could of gone up or down, but in the end I chose to think it did nothing.

In-class journal: I observed the drop in the water level. At first I thought the water level would go down, and I knew I was wrong whatever happened after that because I predict that nothing would happen. Then it went up, and I was surprised, but I didn't know why. I thought well I'm wrong again. I didn't have a clue.

Kama was unable to provide a plausible prediction ('I am not really sure...') as indicated in her prediction response. Her explanation for the observed subsequent rise in water level ('molecules got heated so they got faster and pushed the water out.') was also not plausible to her ('...I am not sure that I am right'). Although Kama was able to explain the subsequent rise in water level she could not explain the initial drop. Using Chinn and Brewer's descriptors (1998, p. 104), the data produced an impasse: Kama accepted the contradictory observation but could not provide any explanation with confidence, either being right or wrong. In brief, she could not solve the problem.

Like Kama, Sharni (Grade 10) also was unable to solve the problem. Sharni's reasons and explanations for her prediction and observation in her POE responses were not making any sense to the teacher/researcher, hence could not be used for data analysis. However, her in-class journal provided some useful information for analysis.

In-class journal: When I observed the drop of water [level], my first thought that came to my mind was that my predictions were wrong. The drop in the water level went down to start of [f] but increased right to the top. I was quite surprised when I realised that the water level increased to the top of the water tube.

When interviewed, Sharni expressed that she expected the water level to 'drop a lot and will not be able increase [rise]'. On clearly observing the initial drop and subsequently a huge rise in water level, Sharni acknowledged her wrong prediction, believing what she observed but she was unable to account for it. Like Kama, the data also produced an impasse for Sharni, whose knowledge was inadequate to predict and explain the phenomenon.

A general inference that could be made from the data analysis of the above nine students was that they all responded to their contradictory observation by accepting it as credible data, which they clearly observed. Four of these students attempted to solve the problem by reinterpreting their observation. Their response was led by two influencing factors: confirming-disconfirming-evidence seeking epistemological commitment (the initial drop and the subsequent rise in water level) and availability of a personally constructed modified but scientifically incorrect theory. The rest of the five students, although they observed the problem, acknowledged their inability to solve it. Their response was led by two influencing factors: confirming-disconfirming-evidence seeking and their inability to construct an alternative theory.

D. Accepting new data and solving the problem with a new theory

The following is an analysis of data from two students who accepted the contradictory observation and solved the problem with a scientifically correct theory.

Kerwin (Grade 12)

Prediction response: The water level will rise higher as the water in the bottle warms up. It will rise because the heat will cause the water to expand. This happens because the heat causes more collisions between them and therefore pushes them further apart.

Observation response: At first the water level dropped and I thought that my prediction was wrong, but after a short while the level started to rise. It ended rising at least 2 inches higher than its original level. This happened because of the reasons I stated and explained in question 1. I am not too sure why the initial drop in water level occurred but I think it has something to do with the glass bottle. Hmmm... I still don't know exactly why it dropped first.

In-class journal: I thought I had made a wrong prediction... As the water was decreasing in level, I was struggling to understand why the water was dropping. I knew it had something to do with the glass bottle but I didn't conclude that it was the glass expanding.

Using descriptors of Chinn and Brewer (1998a, p. 101 to 103) to analyse Kerwin's responses indicated that he experienced and accepted three characteristics of the new data: matching (the subsequent rise in water level), inconsistent (the initial drop in water level) and unexplainable data.

A characteristic of the new data (the subsequent rise in water level) matches with Kerwin's prediction explanation and his expectation and is also consistent with his

prior knowledge. In fact, he justified his knowledge claim by looking for confirming evidence ('but after a short while the level started to rise') - the aspect of the observation that fits his prediction and explanation. Kerwin was able to explain the subsequent rise in water level using his current theory that 'heat causes the water to expand; more collisions occur between molecules; molecules being pushed further apart.'

However, the initial drop in the water level was inconsistent with his initial prediction expectation. This characteristic of the data led Kerwin to reflect on the accuracy of his prediction ('At first the water level dropped and I thought that my prediction was wrong...'). Additionally, the inconsistent data were unexplainable (I was struggling to understand why...) and Kerwin's existing theory of water expansion was insufficient to account for the initial drop in water level aspect of the data.

The inconsistent and unexplainable characteristics of the new data drew Kerwin's attention to the glass bottle, triggering him to initiate a change in his current theory ('...I think it has something to do with the glass bottle'). However, he was unable to progress to the level of further explaining the data using an additional theory ('the glass bottle expanded') that he later learned in the class discussion conducted by the teacher/researcher ('I knew it had something to do with the glass bottle but I didn't conclude that it was the glass expanding').

Similarly, the following data analysis of Dan M. (Grade 11) revealed the glass-bottle-expanded theory as a solution to the anomalous observation.

Prediction response: I believe the water level will rise, and inside the tube it will start to steam, because the heat will form condensation inside the tube. Some sort of pressure from the heat will cause the water level to rise.

Observation response: At first the water level dropped, and then it rose to about $4\frac{1}{2}$ inches above the level that I marked. The reason I believe that happened was it created a vacuum, and then had a great force of pressure from the heat that it overflowed.

Prediction/observation comparison response: My observation was not entirely wrong, because I predicted that it would rise, but did not predict that it would drop at first. So I was partially right and wrong.

In-class journal: What were your reactions and thoughts when you observed the drop in water level?

I was so amazed, because I did not expect that to happen. Then I realized I made a stupid and pathetic prediction. I was very shocked, because the water level dropped and I was wondering where the water went. Because I knew that the container did not get [bigger] so the water level dropped. When I did the experiment I experienced an immediate drop of the water level. Then almost straight after it dropped, the water level rose up and overflowed out of the tube. But maybe the bottle did get bigger.

Dan M., in the face of contradiction between prediction and observation, responded in two ways. Initially, he reflected on the accuracy of his prediction. Then on observing the subsequent rise of the water level, he constructed a 'vacuum theory' to explain his expected observation. Later in his journal, he began to consider his doubted 'bottle-getting-bigger' theory to be a more plausible explanation. The inconsistent and unexplainable characteristics of the new data drew Dan's attention to the glass bottle, triggering him to initiate a change in his current theory. Using Chinn and Brewer's (1993, p. 11) descriptors to explain Dan's reaction, his theory change involved adding an auxiliary theoretical hypothesis to his current knowledge. Moreover, instead of just seeking confirming evidence to support his prediction, he also acknowledged the contradictory observation that disconfirmed it.

It could be inferred from the data analysis of Kerwin and Dan M. that their response to this POE was that of accepting the contradictory observation and solving the problem with a new theory. The influencing factors for their response were the credibility of the data (which were clearly observed) and availability of a correct theory, which they personally constructed independently.

In terms of the students' epistemological commitments, those who observed an initial drop in water level but tended to seek confirming evidence of the subsequent rise in water level to support their prediction are shown in Table 5.5.

Table 5.5. Epistemological responses of students who observed an initial drop in water level (Grade 10-12)

Number of students who recorded	Sought confirming evidence only	Sought disconfirming evidence only	Sought both kinds of evidence	Sought neither kind of evidence
an initial rise (8)	4 (Briony, Sheila, Bobby, Dan B.)	0	0	0
	3 faulty procedure (Amy, Demelza, Becky)	0	1 faulty procedure (Harmony)	0
an initial drop (10)	3 (Nat, Christian, Simona)	0	5 (Dan M., Sian, Nicole, Kerwin, Venetia.)	2 (Kama, Sharni)
Total (18)	10	0	6	2

Summary of Chapter 5

Analysis of data from students on the water-in-glass tubing POE revealed four types of responses to contradictory information: considering observations irrelevant, excluding data not fitting one's theory, accepting new data but unable to explain the phenomenon using scientists' conceptions, and accepting new data and explaining the phenomenon using scientists' conceptions. Therefore, Research Question 2, which sought to evaluate the effectiveness of POE tasks in diagnosing types of students' responses to contradictory observation was somewhat answered.

Although the two aspects of the phenomenon (the initial drop and the subsequent rise in water level in the glass tubing) were observed by most students in the mixed year level class, students' responses were generally influenced by their commitment to focus more on explaining an aspect of the phenomenon (the subsequent rise in water level) that supported their predictions. This commitment was particularly prominent for four students who predicted a rise in the water level but actually did see an initial drop in water level in the glass tubing during the experiment; however, they chose to record only the subsequent rise in water level as their observation to support their

predictions. Three students whose experimental procedures were faulty, resulting in the initial drop in water level being less obvious but which nevertheless was observed also demonstrated a similar commitment. Like the rest in the class, these students focused on explaining the subsequent rise in water level, which they recorded as their observations to support their predictions.

The data indicated that when a phenomenon has more than one feature for observation (example, small initial drop, followed by a large rise in the water level), students tend to be more committed to focus on an aspect of the phenomenon (the subsequent rise in water level) that supported their predictions. This commitment of focusing on a more preferred feature of a phenomenon resulted in the way that some students were recording their observations, that is, they recorded an initial rise instead of an initial drop in water level (although both aspects of the phenomenon were observed).

The next chapter describes the effectiveness of POE tasks, which have only one aspect for students to observe, in diagnosing types of students' responses to contradictory observation.

CHAPTER 6

RESULTS OF THE LIGHT-GLOBES POE TASKS

Introduction

Results of data analysis described in the previous chapter suggest that when a phenomenon had more than one feature for observation, students tended to be more committed to focus on an aspect that supported their predictions. This selective attention tendency also influenced the way that students recorded their observations. Although both aspects of the phenomenon were observed, students tended to record and explain the aspect that supported their predictions. This realisation gave rise to the need to design POEs that produced phenomena that were immediate, clear and had only one aspect for students to observe. Moreover, POEs would need to be administered by way of teacher demonstration, instead of students conducting the POE experiment themselves, to avoid some students committing faulty experimental procedures that affected their observations of the intended phenomenon. In this part of the study, POEs which produced a phenomenon that was clear, immediate and had only one aspect to observe were designed and administered by teacher demonstrations to obtain quality information on students' existing knowledge and on the way they responded to contradictory data. Data generated were analysed and used to assess the effectiveness of POE tasks as a diagnostic tool.

This chapter describes the effectiveness of two simple electric circuit POEs, each with two light-globes, a battery and a switch, in diagnosing how students' responses to contradictory observations were influenced by their existing beliefs and conceptions. At this point the class was taught by the teacher/researcher in two one-hour lessons on current flow in simple series circuits using analogies such as water circuit and marbles in a transparent hose to represent current flow. To reduce variations in students' observational outcomes, the following steps were taken by the teacher/researcher in designing the POEs. First, the POEs were demonstrated by the teacher to avoid students committing faulty experimental procedures. The first POE had two light globes connected in series to a battery with only one of the globes

lighting up (see Figure 6.1a), while the second POE with a similar circuit had both globes light up at the same time if the switch was turned on (see Figure 6.1b). Second, these POEs produced phenomena that were immediate (the globe or globes lit up as soon as the switch was turned on), clear (globes glowed with sufficient brightness) and had only one aspect for students to observe (the glow of the globes).

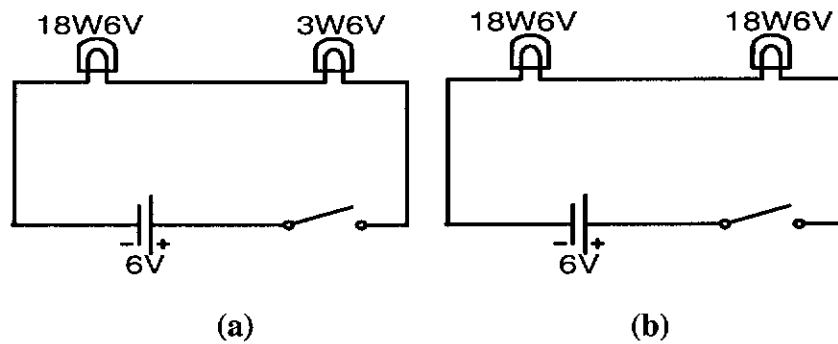

Figure 6.1 Light globes POE 1 and 2 circuit diagrams

The first POE was primarily used to diagnose students' existing knowledge. The researcher's interpretation of students' understanding and conceptions was then checked by the students during class discussion to increase the credibility, validity and plausibility of the data. This is in line with constructivist epistemology that a researcher's interpretation of students' understanding was based on the conceptions that he or she already holds. To remain sensitive to his own conceptions of students' understanding, many times the teacher/researcher revisited the raw data from written responses of the first light-globes POE (Duit, Treagust & Mansfield, 1996, p. 20).

Students' understandings were categorised by listing and grouping their responses based on the similarity of wording and the use of distinctive words or concepts. The categories were shown to the students from whom they were derived in written form and discussed in a whole class setting. The class members were asked to check if the results were plausible (Guba & Lincoln, 1989; Merriam, 1988). Each student compared his or her individual POE responses to each question to categories that were written on the board. For each category to each question, the teacher/researcher asked the members of the class if their answers fitted the categories. Categories that were not representative from the students' viewpoint were modified, changed or even deleted; those categories that were not in the list were added on request by students

based on their individual re-reading of their responses during class discussion. This member check process (Guba & Lincoln, 1989) provided the opportunity for students to correct errors of interpretation of their POE responses due to the teacher/researcher, and to bring out additional constructions of categories during the class discussion.

Moreover, based on previous lessons, the researcher's tentative understanding of an aspect of the class's understanding of electricity ('something that flows') was written on the board in a form of a statement for students to review. The statement was:

Electricity is 'something' coming from the battery, consumed by the globes in differing amount and reaches the globe that is connected nearer to the battery before flowing into the next globe in reduced amount.

Students' agreement or any objections to the statement with accompanying reasons were requested. A common agreement to the statement was that the 'something' coming out of the battery and flows in the circuit is called current. On the basis of this aspect of understanding students' conceptions, a second POE was designed (see Figure 6.1b) to diagnose students' responses. The class was informed that the second light-globe POE would be demonstrated and the commonly agreed statement written on the board may be used as a hypothesis for making their predictions.

The purpose of this part of the research was to elucidate the effectiveness of POE tasks in diagnosing students' existing knowledge and how their existing knowledge influenced the way they responded to contradictory data by using a specific case (electricity) of Research Question 2: How effective is the Predict-Observe-Explain technique in diagnosing types of students' responses to contradictory observations? Specifically, the emerging specific research questions that were to be addressed were:

- 2.1. How effective are POE tasks in diagnosing students' existing conceptions of electricity?
- 2.2. How effective are POE tasks in diagnosing how students' responses to contradictory data are influenced by their existing conceptions of electricity?

**Diagnosis of Students' Existing Conceptions of Electricity:
Light-Globes POE 1 Task**

The class demonstration procedure

At the outset, a class of 16 mixed Grade level (Grade 9-12) students were told that the teacher would demonstrate an experiment and they were asked to predict what will happen and provide reasons for their predictions. The teacher then demonstrated the experiment and students wrote down their observations and explanations.

The demonstration began with the teacher showing two electric light globes (18W 6V and 3W 6V) functioning normally when each was connected individually to a 6-volt DC power supply. The light globes were then connected in series to a 6-volt DC power supply as shown in Figure 6.1a. Before the circuit was switched on, students were independently asked to write down their answers to question 1 in Figure 6.2.

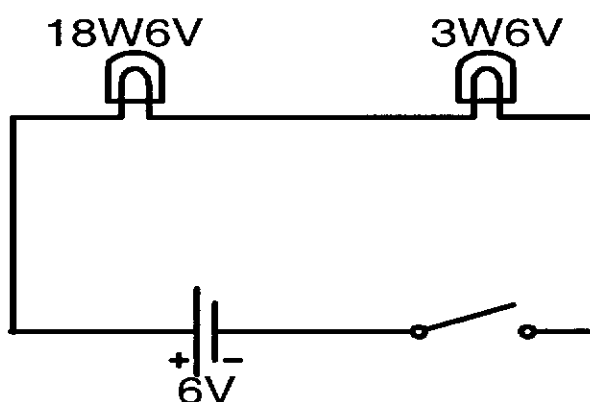

1. *Predict which globe will glow brighter if the circuit is completed. State and explain the reason(s) for your prediction.*
2. *When the circuit is completed what happened? Describe your observation with regard to the relative brightness of each globe. State and explain the reason(s) for your observation*
3. *Compare your observation with your prediction. Are they in agreement or disagreement?*
4. *Discuss your answers to the above three questions in your group and write down your final reasons and explanations.*

Figure 6.2 Circuit and questions for light-globes POE 1

In the next stage of this POE demonstration sequence, the teacher completed the electric circuit. The students were requested to independently write down their observations by answering question 2. During the demonstration, student groups were asked to come to the teacher's bench in turn to have a closer view of the experiment. Students were required to make independent observations and no discussion was allowed.

In the next stage, students were asked to make comparisons between their own predictions and their observations by answering question 3. Finally, students in groups of three or four discussed their answers to the three questions after which each wrote down his or her final reasons and explanations. At each stage of the POE demonstration, students were reminded that this was not a test and their views were requested.

Data collection and analysis

The results of the predictions and observations of the 16 mixed grade students are presented in Table 6.1. Fourteen students predicted the brighter glow of the 18W globe but observed the glow of only the 3W globe. One student predicted and observed the glow of only the 3W globe while another predicted the same brightness of both globes but observed the glow of only the 3W globe. The data suggest that this POE did provide the intended clear and immediate observational outcome experienced by all 16 students (all observed the glow of only the 3W globe). The results show that there was no variation in observations among students.

Table 6.1. Predictions and observations for light globes POE1 on which globe would glow brighter (n=16, Grade 9-12)

Observation of brighter globe	Prediction of brighter globe		
	18W	3W	Same
18W	0	0	0
3W	14	1	1
Same	0	0	0

In order to obtain insights into students' understanding, their response sheets were grouped according to three categories, namely:

- A. Students who made a prediction that only the 18W globe would glow brighter (n=14)
- B. Student who made a prediction that only the 3W globe would glow brighter (n=1)
- C. Student who made a prediction that both globes would glow equally bright (n=1)

For each group of response sheets, categories of individual prediction reasons, individual observation explanations, and group ideas that resulted from student group discussion, were obtained and collated in a draft table based on their similarity of wording and their distinctive use of words or concepts. The draft table of categories was then presented to students on the board in a class discussion. Each student compared his or her individual POE responses to each question to the categories in the draft table. For each category to each question, the teacher/researcher asked the class if their answers fitted any of the categories. Categories that were not representative from the students' viewpoint were modified, changed or even deleted and those categories that were not in the list were added on request by students based on their individual re-reading of their responses during class discussion. These results are presented in Table 6.2, in the above three categories.

Table 6.2. Students' prediction and observation reasons on light globes POE1
(n=16)

A. Students who predict 18W would glow brighter but observed only the glow of the 3W globe (n=14)

Prediction reasons

more watts

uses more electricity/current

receives more electricity/current

closer to power supply, uses up most of the power/current

power is less as it passes through connection

Observation reasons

insufficient electricity or power hence only lights up the 3W globe

power running through above 3W will blow up the 3W globe

placement of globes

18W globe didn't have any charge in it

electricity certainly didn't go to the higher watt

Group ideas

3W globe needs less power

insufficient power for both globes

running power above 3W will blow up the 3W globe

a higher voltage will light up both globes

reverse the positions of the globes

B. Predict 3W to glow brighter and observed the glow of only the 3W globe (n=1)

Prediction reason

3W globe needs less power

Observation reason

3W globe needs less power

C. Predict same brightness but observed the glow of only the 3W globe (n=1)

Prediction reason

same voltage/voltage determine brightness

Observation reason

3W took up all the electricity first

3W globe requires less electricity

Interpretation of Students' Conception of Electricity for Those in Category A

Prediction reasons

For 14 students who predicted the glow of the 18W globe only, their use of the words 'electricity', 'power' and 'current' interchangeably suggests their undifferentiated conceptions between the meaning of those words. These students seemed to have conceived electricity, power or current as synonymous; with more of it being received and consumed ('uses more electricity') by the higher power specification globe ('more watts'). Moreover, the higher power globe was having a positional advantage of being 'closer to the power supply' and hence 'uses up most of the power' in the circuit. Students explained that this was due to power loss or 'power is less as it passes through connection'.

Students' prediction explanations suggested a sequential flow model and a source-consumer model (which was also reported by Driver et al., 1994; Shipstone, 1984) where the battery was the source of electricity from which electricity, power or current flowed to the globes, to be consumed by the globes in differing amount. The electricity reached the globe that was connected nearer to the battery before flowing into the next globe in reduced amount. All students illustrated their models using a free-hand drawn circuit diagram with arrows to indicate the direction of current flow similar to Figure 6.3 along with their prediction explanations.

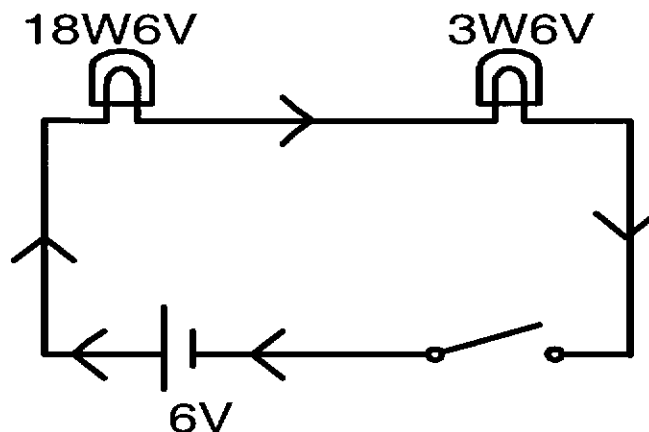

Figure 6.3. Students' free hand circuit diagram

The source-consumer-sequential model was clearly expressed explicitly by students' Question 1 responses, as is illustrated by the following excerpts:

(Susan, Grade 12)

The 18W6V globe will glow brighter. This is because a higher current can get to it. The more watts it has the more electricity it will use, so with more electricity it will be brighter.

To Susan, the 18W6V globe being of a higher power ('more watts') as specified by the manufacturer, was receiving a 'higher current' and also was using more electricity. Susan's use of the words current and electricity interchangeably suggests her conception of those words as synonymous and the globes were consumers of current or electricity in differing amounts; the higher power globe being the larger consumer.

Similarly, Kerwin also demonstrated the globes-as-consumers of power conception with the battery as the source:

(Kerwin, Grade 11)

I think that the globe connected to the positive plug [terminal] of the battery pack will glow brighter. The circuit is 'one-way' and the power is coming out of the positive plug [terminal] and travelling around the circuit and then going into the negative plug. The first globe (the one closest to the positive plug) [which] the power reaches [first] will use up most of the power and the second will glow dimmer as not a lot of power will be left. So that's why the first globe will glow brighter.

The 18W6V globe having a positional advantage ('first globe; the one closes to the positive plug') was the first to receive electrical power from the source ('power pack'). After consuming much of the power, a reduced amount was left ('not a lot of the power will be left') for the next globe to consume. Additionally, Kerwin's question 1 response indicated a sequential flow of electrical power through the circuit. That is, the power flowing through was unidirectional ('one-way') travelling from the positive terminal ('positive plug') of the source, then 'around the circuit' before returning to the negative terminal ('negative plug') of the battery.

Three other students also expressed prediction explanations similar to that of Susan's and Kerwin's in the following Question 1 responses.

(Nicole, Grade 11)

I think that the bigger one [18W globe] will glow brightest because the power will reach the big one first. And the power is less as it passes through the connection so the smaller globe won't receive as much power as the big one.

(Rebecca, Grade 10)

I think that the larger globe will glow brighter. The reason for this is because the direct current starts at the larger globe [18W6V] that is where there is more current than the smaller globe [3W6V], which is where the current is returning back to the battery. There are also more watts so that could also cause a difference.

(Briony, Grade 9)

I believe the 18W6V globe will glow brighter. This is due to the fact that the globe is bigger and it houses more watts, which makes it brighter. Also, the electricity passes through the 18W6V globe first.

Nicole, Rebecca and Briony were expecting the flow of power ('power will reach the big one first'), current ('direct current starts at the larger globe') or electricity ('electricity passes through the 18W6V globes first') to reach the 18W6V globe before flowing into the next globe (3W6V). Moreover, the amount of power, current or electricity was reducing as it flowed from one globe to another in the circuit. This was evident in Nicole's response phrase ('...the power is less as it passes through the connection') and also that of Rebecca's ('... the direct current starts at the bigger globe...where there is more current than the smaller globe').

Observation reasons

Data analysis indicated four theories that were used by students to explain their contradictory observations.

First, on observing the glow of only the 3W globe, students reinterpreted their observation by using a theory of 'insufficient electricity', that is, saying that there was insufficient electricity or power supply in the circuit. Consequently, 'the smaller one which has the least watts lit up' because 'it required less power than the 18W globe'. This is evident in the following observation responses of three students:

(Kerwin, Grade 11)

When the circuit was completed, the second globe (3W6V) glowed very brightly whilst the first (18W6V) did not glow at all! The reason could be because there was not enough power to light both globes, the smaller one lit up and there was not enough power left to make the bigger globe [18W6V] shine even a little.

(Nicole, Grade 11)

When the circuit was completed, the smaller globe (3W) was glowing, but the 18W globe wasn't glowing at all. This must be because there is not enough power to light up both of the bulbs, so the smaller one, which has the least watts lit up.

(Dan M, Grade 10)

My observation showed me that the 3W6V globe glowed more brightly than 18W6V globe. The reason why I think this happened was the 18W6V globe could not get enough power because of the other one [3W6V].

One may interpret from phrases like '...not enough power to light both globes...' and '...the 18W6V globe could not get enough power because of the other one.' that students were constructing a theory of 'insufficient power' in the circuit to explain their observations. The data suggested that students applied the source-consumer to explain their contradictory observations.

Second, a 'globe-preserving' theory favouring the smaller 'watt' globe was constructed to explain their observations. An example of students' theory was as follows: '...the power running through the circuit could not get higher than the smallest watt or that light [globe] would blow' (Susan, Year 12). The globe-preserving theory served as a condition, determined by the globe with a lower power specification, for the amount of power supplied by the battery to the globes in the circuit. The amount of power supplied was sufficient to light up the 3W globe without destroying it but insufficient to light up the 18W globe in the series circuit. The globe-preserving theory derived from the data could be interpreted as students' application of the source-consumer model.

Third, an 'all power-consumed' theory again favouring the smaller watt globe was constructed by two students to account for the glow of only the 3W globe. This is suggested by their following observation responses:

(Harmony, Grade 11).

'When the circuit was connected the 18W6V globe didn't shine at all and the 3W6V globe shone brightly. This happened because the power supply was aware of the second globe and supplied all of its energy to that globe'

(Nat, Grade 10).

'...The 3W globe glowed and the 18W globe didn't glow at all. The 3W globe was quite bright and from what I could tell the 18W globe didn't have any charge in it from when the circuit was not completed'

Ascribing an anthropomorphic property for electrical power, Harmony argued that 'the power supply [battery] was aware of the second globe [3W] and supplied all of its energy to that globe'. While Nat commented that 'the 18W globe didn't have any charge in it', this comment was echoed in her question 3 response '...electricity certainly didn't go to the higher watt globe'. Again this all-power-consumed theory could be interpreted as an application of the source-consumer model to explain the observed glow of only the 3W globe.

Fourth, a 'close-proximity' theory of the 3W globe to the battery was used to reinterpret their contradictory observations. One student (Dan M, Grade 10) argued that 'the 3W globe was closer to the power base', 'used up some of the power supplied to the circuit' and resulted in 'the other globe [18W] not getting enough power' for it to glow. He later hypothesised that 'if the placement of the globes was in a different order, the larger one [18W] would glow'. Instead of hypothesising, Rebecca (Grade 10), actually used the 'placement of globes' theory to explain her contradictory explanation ('...I think it had something to do with placement of the globes...'). The close-proximity theory also was used by another student (Briony, Grade 9) who argued that 'the smaller globe [3W] received the negative electricity first' leaving very little for the 18W globe to light up. In using the close-proximity theory, students were applying the source-consumer-sequential model to reinterpret their contradictory observations.

The four types of reasons, namely, 'insufficient power/electricity', 'globe-preserving', 'all power-consumed' by one particular globe, and 'close-proximity' constructed by students during their observation stage of this POE may be

interpreted as their ways of applying the source-consumer sequential model of electricity to explain their contradictory observations.

Group ideas

Data analysis of student responses to question 4 of this POE suggested a consensus of two theories, which were used in explaining their contradictory observations. First, there was 'insufficient power for both globes' in the circuit to glow. Second, the power distribution around the circuit must be globe preserving, otherwise 'running power above 3W will blow up the 3W globe'. Additionally, the data analysis suggested students' construction of two hypotheses. First, as an application of their source-consumer-sequential flow model, they suggested to 'reverse the positions of the globes' with the 3W globe receiving the power first. Being a smaller watt globe, they predicted that it would have consumed a smaller proportion of the power supplied, leaving sufficient remnant power to light up the 18W globe. Second, the students seemed to recognise that each globe required 6 volts to light up and suggested a power supply of 'a higher voltage will light up both globes'. Although, it may be interpreted that the students were suggesting a higher voltage power supply for the whole circuit, there was no evidence from the data that they were applying the scientist's notion of voltage distribution between the two globes around the circuit. As indicated by the data, students had an undifferentiated view of current and voltage. Current, power and electricity were used interchangeably as something that flows, with the smaller globe (3W) needing less of it, thus accounting for the globe's lighting up.

Interpretation of students' conception of electricity for those in category B

While the majority (14 students) of the students predicted that the glow of the 18W globe would be brighter, only one student (Christian, Grade 11) predicted and observed the glow of only the 3W globe. This student applied the source-consumer model by giving '3W globe needs less power' as the prediction reason and to explain the observation.

Interpretation of students' conception of electricity for those in category C

Although most students used the dual source-consumer-sequential model to reason out their predictions, this particular student (Joshua, Grade 11) did not. Instead his prediction was for the same brightness of the globe because both globes were of the 'same voltage/voltage determine brightness'. His reasoning seemed to suggest that it was the globe's specification voltage (the 6V needed for normal brightness specified by the manufacturer) rather than the operating voltage (the actual voltage) across each of the globes that determined their brightness. However, on experiencing the contradictory glow of only the 3W globe, he applied the source-consumer-sequential model stating '3W took up all the electricity first' and '3W globe requires less electricity' as his explanations to account for the observation. Similar findings were obtained earlier in a different school by the author (Liew, 1998) where he taught three separate single grade classes, namely, a class of 25 Grade-9 students, a class of 6 Grade-11 students and a class of 10 Grade-12 students, where students' prediction reasons suggested that the globes' specification power (labelled on the globes by the manufacturer) and not the globes' operating power (due to the actual current flowing through the globes' filament) determined the globes' brightness.

Reflection on light-globes POE 1

Data analysis of the first light-globe POE suggested that students' existing conceptions of electricity were of a source-consumer sequential model. Students' understanding of words such as electricity, current, voltage, watt and power were undifferentiated. The types of reasons, namely, insufficient power/electricity, globe-preserving, all power-consumed by one particular globe, close-proximity and brightness being determined by the globe's specification power-constructed by students during their observation stage of this POE may be interpreted as their ways of applying the source-consumer sequential model of electricity to explain their contradictory observations. As a consequence of the model, students failed to recognise the current conserved characteristic of the series circuit used in this POE. This type of student response has been reported by several researchers including Liew (1998), Osborne and Freyberg (1985), and Shipstone (1984).

On the basis of the data analysis and interpretation of students' understanding, the researcher reconstructed an aspect of students' conceptions as follows:

Electricity is 'something' coming from the battery, consumed by the globes in differing amount and reaches the globe that is connected nearer to the battery before flowing into the next in reduced amount. That 'something' may be called current.

This statement was presented on the board for students to comment upon. Generally, students agreed with the statement and the researcher suggested that they might use it as a hypothesis for the next light globe POE.

Diagnosis of Students' Responses to Contradictory Data: Light-Globes POE 2

The second POE was designed to diagnose how students' responses to contradictory data were influenced by their existing knowledge and beliefs of a phenomenon. Specifically, this section described the effectiveness of the second POE in diagnosing how students' responses were influenced by their source-consumer sequential model of electricity diagnosed using the previous POE. Student responses were categorised using a framework adapted from Chinn and Brewer (1993, 1998) that comprises eight categories, namely, ignoring data, rejecting data, professing uncertainty about the validity of the data, excluding the data from the domain of the current theory, holding the data in abeyance, reinterpreting the data, accepting the data and making peripheral changes to the current theory, and accepting the data and making changes to the current theory.

Using the same classroom demonstration procedure adapted from light-globes POE 1, light-globes POE 2 also was demonstrated by the teacher/researcher to the mixed grade class. The purpose of using the classroom demonstration procedure was to avoid students committing faulty experimental procedures. These two demonstrations were conducted about 5 weeks apart from each other. Students' light-globes POE 2 response sheets read as shown in Figure 6.4.

Two identical electric light globes (18W 6V) function normally when each is connected to a 6-volt DC power supply. The light globes are then connected, with an ammeter before and an ammeter after the first globe, in series to a 6-volt DC power supply as shown in the diagram below.

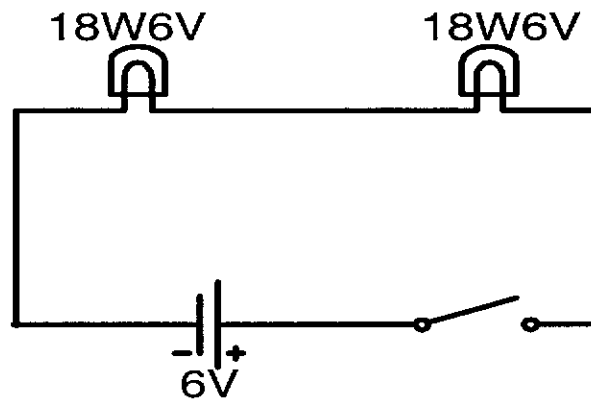

1. *Predict which globe will receive current first and which one will receive more current if the circuit is completed. State and explain the reason(s) for your prediction.*
2. *When the circuit is completed which globe is the first to receive current and which one receives more current? Describe your observation. State and explain the reason(s) for your observation.*
3. *Compare your observation with your prediction. Are they in agreement or disagreement?*
4. *Discuss your answers to the above three questions in your group and write down your final reasons and explanations.*

Figure 6.4 Circuit and questions for light globes POE 2

Data collection and analysis

The results of the predictions and observations of the 18 mixed grade (Grade 9-12) class students are shown in Table 6.3. Sixteen students predicted the globe that was closer to the battery would glow or receive current first but observed the simultaneous glow of both globes. One student who had his observation influenced by his existing beliefs and conceptions (a source-consumer sequential model) predicted and ‘observed’ the globe closer the battery was the first to glow, while another student, using his theory of ‘insufficient voltage’ in the circuit, predicted none of the globes would glow but observed the simultaneous glow of both globes. The data suggest that most of students (17 out of 18) in the class observed the

simultaneous glow of both the globes showing very little variations in students' observational outcome.

Table 6.3. Predictions and observations of the second light-globes POE (n=18)

Observed	Predict			
	Globe closest to battery	Globe furthest from battery	Same time	None will light up
Globe closest to battery	1	0	0	0
Globe furthest from battery	0	0	0	0
Same time	16	0	0	1

The types of students' responses are shown in Table 6.4. Although 17 students observed the simultaneous glow of the globes, they responded differently to the contradictory data. Among those who accepted the contradictory data, most (13 out of 16) were not able to explain their observations using scientists' conceptions. Nine of these 13 students tried to explain their observations by making peripheral change to their existing theory, while two students acknowledged their inability to explain the data in anyway (they experienced an impasse). Two students also tried to explain differently by reinterpreting the contradictory data. While most students were unable to explain their observation using scientists' conceptions, three explained it by changing their existing theories.

Table 6.4. Features of each of the responses to anomalous observations (n=18)

Type of response	Features of response		
	Does the student accept the data?	Does the student explain the data?	Does the student change theory?
B. Rejecting data (2) (Susan, Christian)	No	Yes	No
C. Accepting new data, unable to explain their observations scientifically (13) and:			
C 1. Reinterpreting (2) (Dan. S, Sian)	Yes	Yes but wrong	No
C 2. Acknowledging inability to explain data in anyway (2) (Kama, May)	Yes	No	No
C 3. Peripheral theory change (9) (Joshua, Kerwin, Amy, Nicole, Harmony, Becky, Venetia, Briony, Sheila)	Yes	Yes	Yes/modified
D. Accepting and explaining new data scientifically (3) (Dan M, Simona, Bobby)	Yes	Yes	Yes

Interpretation of students' responses and excerpts from students' data

The organisation of this report on students' responses was grounded using data sources that included students' written POE responses and interview excerpts. Descriptors and criteria for classifying students into categories of responses to contradictory observations adapted from Chinn and Brewer (1993, 1998) were used as a guide. Factors related to categories were identified from students' descriptions

and explanations for their observations, from comments they made about their own observations and explanations, and from convictions of their comments and explanations reflected by their language (phrases and expressions).

B. Rejecting data as being invalid

Two students in the mixed year class who observed the simultaneous glow of the two light globes did not accept the contradictory data. Excerpts from their POE response sheets were analysed and categorised as follows:

Susan (Grade 12)

Prediction: 'The globe closest to the positive terminal will receive the current first, but they will both receive the current so quickly that the human eye could not pick the difference. The globes will receive the same amount of current as they are identical globes.'

Observation: 'They both seem to light up at the same time,...same brightness. ...both receiving the same amount of current because the ammeters indicated this.'

Christian (Grade 11)

Prediction: 'The one nearest the positive connection will light up first because the current reaches the closest one first as it travels to the negative connection. But this cannot be seen with the natural eye because the current travels too fast.'

Observation: '...it looked like they received it the same time. ...the current travels so fast, you can't see it with your natural eye. They both received equal current... because they are same wattage globes.'

The above data showed that Susan and Christian used a 'high speed sequential-equal-current-sharing' theory to account for their prediction of the glow of one globe prior to the other as indicated in their prediction phrases: '...current reaches the closest one first as it travels to the negative connection.' '...this cannot be seen with the natural eye...current travels too fast.' '...globes will receive same amount of current, as they are identical globes.' Similar phrases were used in their written observation responses to explain their rejection of the contradictory data. They rejected the contradictory data by suggesting that '...it looked like they received it the same time' or 'They both seemed to light up at the same time...' and used a high speed sequential equal current sharing theory to explain their rejection of the contradictory data. The above analysis of data from Susan and Christian suggested that their reason for rejecting their seemingly contradictory observations was that the

human eye was an inadequate observation instrument for a high-speed current phenomenon.

C. Accepting data but unable explain them scientifically

Thirteen of 18 students accepted their contradictory observations of both globes receiving the current at the same time in equal amount and with the same brightness, but were unable to account for their observations in a scientifically correct manner. Students responded to their contradictory observations in three ways: Reinterpreting the data, acknowledging an impasse, and making a peripheral theory change.

C1. Reinterpreting

Excerpts from POE response sheets of two students and their interviews were analysed and categorised as 'reinterpreting'. The analysis of the first one, Dan S, a Grade 11 student, proceeded as follows:

Dan S (Grade 11)

Prediction: '...the globe closest to the positive outlet will receive the current first, but this does not necessarily mean that the other globe will not receive any current, and not glow at all.'

Observation: 'none of them received more current, as the ammeter read 1.7. What I did notice was that one globe had glowed brighter for a second before reducing down [in brightness] to the same as the second globe.'

The above data from Dan S showed that he used the 'close-proximity' theory to explain his prediction, that is, 'the globe closest the positive outlet will receive the current first...' The latter part of Dan S's prediction response '...but that does not necessarily mean that the other globe will not receive any current and not glow at all', suggested that some current would be received by the second globe. However, on observing the readings of both ammeters being 1.7A, Dan S accepted the contradictory data, namely, '...none of them [globes] received more current.' Although, the data have a credibility characteristic (clearly observed ammeter readings) which influenced Dan S's acceptance, he reinterpreted his contradictory observation using his own 'close-proximity momentary unequal current sharing' theory. This was evident in his observation response, 'What I did noticed was that one globe had glowed brighter for a second before reducing down [in brightness] to

the same as the second globe.’ And that the brightness of globes was related to the amount of current they received was evident by the following interview excerpt:

Teacher: How was your observation of ‘one light globe glowed brighter for a second...’ related to current flow in the circuit?

Dan. S: The first globe was brighter for about 1 second because it was closer to the positive output at the battery; therefore it received a flow of electrons before the second globe. When the electrons reached the second globe, the first globe dimmed down to the same brightness as the second globe. That is because the first globe for a second received slightly more current than the second globe.

Dan. S’s ‘close-proximity momentary unequal current sharing’ theory could be interpreted as his own way of applying the source-consumer sequential current consumed model.

Similarly, Sian (Grade 10) used the sequential current model to explain her prediction and observation as described in the following analysis:

Prediction: ‘...the globe closest to the positive point will light up first and brightest because the current of electricity will first come to this globe’.

Observation: ‘...the globes light up at exactly the same time and the ammeter readings are identical (at 1.7A). I think the reason for this is that the current is not complete until the current has returned to the negative [terminal] after coming out of the positive [terminal] so by the time the current is complete both globes have electricity’.

Sian’s prediction reason for one of the globes to light up first and brightest was that the globe was ‘closest to the positive point’ and therefore received the current first. Although her observation was inconsistent with her prediction, Sian accepted her contradictory observation that had a credibility characteristic (identical ammeter readings). She explained the simultaneous glow of the globes using a ‘positive terminal to negative terminal’ current flow theory. When the current had completed its journey around the series circuit, the globes were considered to have possessed electricity, thus accounting for their simultaneous glow and identical ammeter readings. Sian’s current-completed-journey theory suggested a condition or a requirement to be fulfilled in the circuit for the simultaneous glow of the globes. This

theory of condition or requirement was Sian's way of applying the sequential current model to reinterpret her contradictory observation. Like Dan S, Sian accepted the contradictory observation but was unable to account for it in an acceptable scientific way.

C2. Acknowledging an impasse (inability to explain observations in anyway)

The following is an analysis of data from two students who either experienced or acknowledged an inability to account for the contradictory observations. Unlike Dan S and Sian, however, these two students faced an impasse; they could not or did not provide any explanation right or wrong, for their observations.

The first student was Kama (Grade 9) who used the close-proximity theory to make her prediction as indicated by the following data:

Prediction: '...the one closest to the battery will receive the current first. I don't think any will receive more current.'

Observation: '...they both received the current at the same time. They both received an equal amount of current. I don't have a clue as to why...'

Although Kama was able to describe her contradictory observation, namely, both globes received current 'at the same time' and in 'equal amount', she acknowledged her inability to explain her observation 'I don't have a clue as to why...'.

Similarly, May (Grade 12) was able to describe her contradictory observation, but she did not or could not provide any explanation. Like Kama, May experienced an impasse as indicated by the following data:

Prediction: '...the globe closest to the positive terminal of the power supply will receive the current first. ...They will eventually receive the same amount of current.'

Observation: It looks like they both lit at the same time, so I'm going by that. They both received exactly the same amount 1.7A of current.'

C3. Peripheral theory change

Excerpts from POE response sheets of nine students were analysed and categorised as ‘peripheral theory change’. The analysis of Joshua (Grade 11) proceeded as follows:

Prediction: ‘The first globe. ...The first globe is near to where the current starts off. They will both receive the same amount [of current]...they have the same number of watts.

Observation: They received the current at approximately the same time and in the same amounts. ...Because the rate of the moving electrons was so fast through the circuit. I think they received the same current because the bulbs had the same number of watts. The same number of watts means the current somehow ‘feels’ it must give each bulb equal current.

The above data from Joshua showed that he was using a ‘close-proximity equal current sharing’ theory to explain his prediction. That is, the globe that was nearer the battery would receive current first and both globes being of equal wattage (globe power specification) shared equal amounts of current from the battery which was the source of the current. In his observation, Joshua stated that the globes received current at about the same time and in equal amount. From the teacher/researcher’s viewpoint, Joshua could have observed the simultaneous glow of the globes and the momentary deflections of the ammeters and inferred that the globes received the current from the battery at more or less the same time and in equal amount. He then reinterpreted his contradictory observation and inferences using a modified theory, with additional properties, namely, a high speed (‘rate of moving electrons was so fast through the circuit’) and anthropomorphic current (‘the current somehow ‘feels’ it must give each [identical] bulb equal current). Joshua explained the contradictory data by making a peripheral theory change from a ‘close-proximity equal current sharing’ one to a ‘high-speed anthropomorphic sequential current sharing’ theory. He responded to the contradictory observation by accepting it and constructing additional properties to his electric current theory to explain the phenomenon. Although, Joshua made a peripheral theory change, his core theory, a sequential current model, remained unchanged. Essentially, he was applying a ‘source-consumer sequential current sharing’ model to account for the observed contradictory data and inferences.

An analysis of Kerwin's (Grade 11) responses proceeded as follows:

Prediction: I predict that the globe connected first in the series will receive more current and it will receive the current first. ...Because current flows from positive to negative and the first globe will 'consume' some of the current before it reaches the second.

Observation: I observed the completed circuit several times and concluded that neither the first, nor the second globe was the first to received the current, and neither of them received more current (the ammeter readings were both the same, 1.7). I believe that the current did actually reach the first before the second; the human eye is not sufficient to observe the slight difference. Because the globes required the same current, it was distributed evenly between the two of them.

Kerwin used a 'sequential current consumed' theory to predict that the globe nearer the battery would not only receive the current first, but it would also receive more current. This was evident in his prediction explanation '...Because current flows from positive to negative...' One could infer from Kerwin's data that the current flowed out of the positive terminal of the battery into the globes and then back to the negative terminal of the battery.

However, Kerwin's observation data suggested that he needed to make changes to his prediction theory to account for the contradictory data he inferred from his observation. That is, on observing the simultaneous glow of the globes and the deflections in the ammeters, Kerwin inferred that both globes received the current at the same time and in equal amount. He accepted the contradictory data but accounted for it by changing his theory peripherally from 'a current-consumed sequential theory' to 'a high speed ('...the human eye is not sufficient to observe the slight difference.') equal current sharing sequential' theory. Kerwin's core theory was essentially a sequential current one and it remained unchanged.

An analysis of data of Amy and Nicole, both in Grade 11, proceeded as follows:

Amy

Prediction: ...the globe that is closest to the power supply will light up first. ...The globe further away from the power supply will receive more current ... because it is the last globe.

Observation: The globes got the same amount of current, and they received the current at roughly the same time. ...Because of the amount of electricity there was

enough for both globes to receive and it went from the power supply quickly enough for them to both receive the current at the same time.

Nicole

Prediction: I think that the first globe will light up first. ...As the current continues, it is already been used up a lot by the first globe so it doesn't light up the second one.

Observation: ...both globes lit up at the same time. This is because the current moves so quickly round the circuit...

Both Amy and Nicole used the 'close-proximity sequential current consumed' theory to predict the glow of one globe before the other. Amy explained that the globe was 'closest to the power supply...' while Nicole predicted that the second globe will not glow because '...current has been used up a lot by the first globe...'. On observing the simultaneous glow of the globes, Amy and Nicole made peripheral change to their theory by adding a high-speed property to their electric current theory. Their theory change was from a 'close-proximity sequential current consumed' theory to that of a 'high speed sequential current' theory, which was an application of the 'source-consumer sequential current model'.

An analysis of the responses of Harmony (Grade 10) proceeded as follows:

Prediction: ...the globe nearest the positive terminal will receive the current first because that is closer to the power supply and that's the way the current goes (from positive to negative). ...Both will receive the same amount of current because the circuit is closed and the current can flow freely.

Observation: ...both globes received the same amount of current at the same time. ...Because the current flows at the speed of light which is not detectable by us [our eyes]. Both globes received the same amount of current because the current is not used up by the globes, the current just passes through them.

Harmony used a slightly different theory compared to Amy and Nicole to predict the glow of one globe ahead of the other. Instead of using a 'current consumed' theory, Harmony used a 'close-proximity sequential current conserved' theory. This was suggested by her prediction explanation '...because that [globe] is closer to the power supply...' and 'Both will receive the same amount of current because the circuit is closed...'. On observing the simultaneous glow of the globes, Harmony changed her theory slightly to a 'high speed sequential current conserved' theory. This was indicated by her observation reason, '...the current flow at the speed of light, which is

not detected by us [our eyes]' and '...the current is not used up by the globes, the current just passes through them'. Harmony responded to the contradictory observation by making a peripheral theory change to her core theory, namely, a 'sequential current conserved' model.

An analysis of the next four students proceeded as follows:

Becky (Grade 10)

Prediction: ...globe number 1 will receive the current first because it is at the beginning. ...But the second globe will glow the same amount or brighter because [it is] the last globe in the circuit.

Observation: The globes both light up at the same time. But the first one probably lights up first because it is at the beginning... it [current] was too quick for the human eye and they both received the same amount of current which is 1.7 Amps...because they are of equal watts and volts...

Sheila (Grade 9)

Prediction: I think that the hypothesis is right in saying that the electricity reaches the globe that is connected nearer to the battery.

Observation: No globe seen from the naked human eye lights up first, but both globes light up at the same time. The amps are also the same... because both globes were 18W this time...

Briony (Grade 9)

Prediction: I agree with the hypothesis that electricity will reach the first light bulb on the left and will go on to the next with a reduced amount.

Observation: The light bulbs both appear to light up at the same time. But I think the first light bulb lights up slightly faster because the electricity comes from the positive and goes back into the negative side. I am not totally sure if this is correct. It's really just a theory, but it seems to explain what I have seen.

Question 3 response: They are in disagreement [prediction and observation] because in my prediction I thought the first light bulb would light up first, and a few seconds later the second one would. But electricity travels so fast that it appears that they light up at the same time.

Venetia (Grade 9)

Prediction: ...the globe closer to the power supply [will] receive current first...because it is closer.

Observation: ...I could not really notice the difference in which globe lit up first.
Question 3 response: My observations and predictions are not in total agreement. This is because the gap between the two light bulbs being lit up is just too small to even notice.

All of the above four students used a 'sequential current' theory to predict that the current would reach the globe closer to the battery. This was indicated by their prediction response phrases: '...it is at the beginning...', '...connected nearer to the battery', '...first bulb...', and '...globe closer to the power supply...'. On observing the instant glow of both the globes, these four students changed their theory slightly to a high speed sequential current theory as indicated by their observation response phrases: '...it[current] was too quick for the human eye...', 'No globe seen from the naked human eye lights up first...', '...electricity travels so fast that it appears that they light up at the same time...' and '...the gap between the two light bulbs being lit up is just too small to even notice.'

To provide the teacher/researcher with a better understanding as to why Briony's response was categorised as 'peripheral theory change', her data were compared and contrasted with those of Susan's and Christian's who rejected the data. It is noteworthy to realise that these students have similar observation phrases such as 'seem to light up at the same time', 'it looked like they received it the same time' and 'both appear to light up at the same time'. They all used a high speed sequential current theory to account for the apparent simultaneous glow of the globes. However, there was a contrast between Briony's prediction response and those of Susan's and Christian's. Briony, on the basis of a 'sequential current' theory, was expecting a time difference of 'a few seconds' between the glow of the globes, as indicated in her question 3 response. While Susan and Christian, on the basis of a 'high speed sequential current' theory, was not expecting an observable time difference between the glow of the globes in their prediction responses.

Inconsistency between her observation and prediction created a need for Briony to modify her sequential current theory. For Susan and Christian, the observed apparent simultaneous glow of the globes was expected but could not be accepted as valid data, due to two reasons: the human eye was an inadequate observation instrument for a high speed current and their existing theory could explain both their predictions and observations. Hence, unlike Briony, theory modification or theory change for Susan and Christian was unnecessary. Results of the above analysis of data from

these three students led the teacher/researcher to categorise Briony's POE response differently to those of Susan's and Christian's.

D. Accepting data and solving the problem by changing theory

An analysis of data from Dan M and Simona who accepted the contradictory data and solved the problem by changing their theory proceeded as follows:

Dan M (Grade 10)

Prediction: ...the first globe will light up before the second globe. ...Both will get the same amount of current. Because they are the same watts.

Observation: ...both received current at the same time. We connected the circuit and put on the ammeters to measure the current. I observed that both lights lit up at the same time.

Interview:

Teacher: Can you explain the reason for your observation?

Dan M.: ...they both lit up at the same time, because when the switch was turned on the current flowed through the circuit and both globes lit up instantly. The current [electrons] was already in the circuit but when it was turned on it bumped the current, just like when you get a row of tennis balls and you pushed one they all move at the same time, and the current produces this effect.

Simona (Grade 9)

Prediction: ...the first one to light up which receives the current first...

Observation: ...both of the globes light up at the same time and the ammeter showed 1.7 for both globes. So they were equal.

Interview:

Teacher: Simona, can you explain the reason for your observation?

Simona: The current moving along is like a row of tennis [balls] all by each other's side, when the first one moves they all move because the first one pushes the next, which then pushes the next and the next and so on. So it is like the electrons in a current. They all get pushed against each other and move along.

The above excerpts from written POE responses and interviews suggested that Dan M and Simona used a 'sequential current' theory to predict that one globe would light up before the other. On observing the simultaneous glow of both globes, neither Dan nor Simona provided any explanation for their observations. However, when

interviewed both were able to provide an 'instant-current' theory to explain their observations. They used a tennis-balls-in a row analogy presented by the teacher in a previous lesson to explain the mechanism of instant current in the circuit. This was evident by their interview response phrases: '...just like when you get a row of tennis balls and you pushed one they all moved at the same time...' and 'when the first one moves they all move because the first one pushes the next, which then pushes the next and the next and so on.' The above data analysis suggested that the contradictory observation of a simultaneous glow of the globes triggered a theory change from a 'sequential current' theory to that of an 'instant current' theory for Dan and Simona.

The data analysis of the third student who had a different prediction from that of Dan and Simona proceeded as follows:

Bobby (Grade 9)

Prediction: '...none of the globes will light because there is not enough volts...'

Observation: 'I saw that both of the globes light up... around the same brightness. I couldn't really tell which was the first to light up...'

Question 3 response: I was wrong. I thought that there wouldn't be enough volts to light up both globes, but obviously there was.

On the basis of his theory of 'insufficient voltage', Bobby was not expecting any of the globes to glow. When the switch was turned on, he observed the glow of both the globes and accepted the contradictory data ('I saw that both of the globes light up...') and changed his theory from one of 'insufficient voltage' to that of 'sufficient voltage' as indicated by his question 3 excerpts 'I was wrong. I thought that there wouldn't be enough volts to light up both globes, but obviously there was.'

Although Bobby was able to explain the lighting up of the globes using his modified theory of 'sufficient voltage', it is not clear from his data that he did actually observe and explain the simultaneous glow of the globes. His expression '...I couldn't really tell which was the first to light up...' seemed to suggest that Bobby may have accepted the simultaneous glow of the globes as his observation. In order to ascertain

this possible response, an interview with Bobby by the teacher/researcher was conducted as follows:

Teacher: Bobby can you relate the current flow in the circuit to your observation that 'you couldn't tell which globe light up first.'

Bobby: I think they light up at the same time because there is always current in wires and when the switch is connected it makes the current push through the whole circuit and because there is always current in wires both globes light up.

Teacher: What do you mean by 'there is always current in wires'?

Bobby: The reason I say this is because when we had a class you taught us using the tennis balls experiment. I think that there is always current in the circuit because the voltage pushes these currents. When we put a force on the tennis balls, all the balls moved because the force travelled through the balls and no matter how long and how many balls we have, the balls will always move.

The above interview excerpt phrase 'I think they light up at the same time' suggested that Bobby accepted the simultaneous glow of the globes as his credible observation. His explanation 'there is always current in wires and when the switch is connected it make the current push through the whole circuit...' was made clearer by his use of an tennis-balls-in-a-row analogy that he had learned earlier. To Bobby, the current in the circuit was likened to a row of tennis balls which moved simultaneously when one of them was pushed by 'the voltage', resulting in an instant current through the circuit lighting up both globes simultaneously. The above analysis of data from Bobby suggested that the contradictory observation of the glow of the globes triggered a theory change from an 'insufficient voltage' to that of a 'sufficient voltage' theory. Moreover, Bobby was able to use an 'instant current' theory to account for the simultaneous glow of the globes.

A summary of students' responses to POE2 in terms of a modified Chinn and Brewer's model is given in Table 6.5 on page 142 and 143.

Table 6.5. Summary of students' responses to POE2 in terms of a modified Chinn & Brewer's model (n=18)

Students' name	Initial theory	Response to POE2 in terms of Chinn and Brewer's model	Does the student accept the data?	Does the student explain the data?	Does the student change theory?	Student's final theory
Susan and Christian	High speed sequential equal current sharing theory	Reject data	No	Yes	No	None
Dan S.	Sequential momentary unequal current sharing theory	Reinterpret data	Yes	Yes but wrong	No	None
Sian	Sequential current with a current-completed-journey requirement for globes to glow simultaneously	Reinterpret data	Yes	Yes but wrong	No	None
Kama and May	Sequential current theory	Acknowledge inability to explain data	Yes	No	No	None
Joshua	Sequential equal current sharing theory	Peripheral theory change	Yes	Yes	Yes/ modified	High speed sequential anthropomorphic equal current sharing theory

(Continued)

Table 6.5. Continued

Students' name	Initial theory	Response to POE2 in terms of Chinn & Brewer's model	Does the student accept the data?	Does the student explain the data?	Does the student change theory?	Student's final theory
Kerwin	Sequential unequal current consumed theory	Peripheral theory change	Yes	Yes	Yes/ modified	High speed sequential equal current sharing theory
Amy and Nicole	Sequential unequal current consumed theory	Peripheral theory change	Yes	Yes	Yes/ modified	High speed sequential current theory
Harmony	Sequential current conserved theory	Peripheral theory change	Yes	Yes	Yes/ modified	High speed sequential current conserved theory
Becky, Sheila, Briony and Venetia	Sequential current theory	Peripheral theory change	Yes	Yes	Yes/ modified	High speed sequential current theory
Dan M., Simona and Bobby	Sequential current theory	Theory change	Yes	Yes	Yes	Instant current theory with a tennis-ball-in-a-row analogy

Reflection on the Effectiveness of Light-Globes POEs in Diagnosing Students' Understanding

Diagnosis of students' understanding of electricity using the second light-globe POE revealed that students applied their 'source-consumer' model of electric current in five ways (see Table 6.5 on page 142 and 143).

1. Two students rejected their observations (both globes seemed to light up at the same time) because they were influenced by their conceptions that the human eye was an inadequate observation instrument for a high-speed sequential current sharing phenomenon.
2. Nine students using a 'sequential current' theory were expecting one globe to receive the current and glow before the next one. On observing the simultaneous glow of the globes, they responded by accepting and reinterpreting their contradictory data by making a peripheral change (modifying) to their existing theory to that used by the previous two students who rejected their observation, namely, the high speed sequential current produced effects that were too quick to be observed by the human eye. Furthermore, two of these nine students each had their own added feature of 'high speed sequential current' theory. One constructed an anthropomorphic property (the current feels it must give each bulb equal current) while the other student constructed a current conserved property.
3. Two students who also reinterpreted their contradictory observations were each using their own unique theory. One used a 'momentary unequal current' theory to account for an 'observed' one second delay for both globes to eventually glow simultaneously. The other student (Sian, see page 18) used a 'current-completed-journey' theory as a requirement to be fulfilled in the circuit before a simultaneous glow of both globes to occur.

4. Three students responded to the contradictory data by having their 'sequential current' theory changed to an 'instant current' theory using a tennis-balls-in-a-row analogy.
5. Two students responded by expressing their inability to account for their contradictory observation (they experienced an impasse).

In short, one could infer that the light globes POE was effective in diagnosing students' ontological understanding (students' views) of the electric current. Specifically, their theories of the electric current to account for their observation were described as being:

- a 'high speed sequential current' theory which states that the electric current moves so quickly in the circuit that both globes appear to receive it at the same time (Amy, Nicole, Becky, Sheila, Briony and Venetia).
- a 'high speed sequential equal current sharing' theory which states that the electric current moves so quickly in the circuit that both globes appear to receive it at the same time and the globes being identical (same power specification as labelled by the manufacturer) receive equal share of the current from the battery (Susan, Christian and Kerwin).
- a 'high speed sequential current conserved' theory which states that the electric current moves so quickly in the circuit that both globes appear to receive it at the same time and both globes receive the same amount of current because the current is not used up by the globes, the current just passes through them (Harmony).
- a 'high speed anthropomorphic current sharing' theory which states that the electric current moves so quickly in the circuit that both globes appear to receive it at the same time and the globes being identical (same power specification as labelled by the manufacturer) makes the current 'feels' that it must give each globe equal share of the current (Joshua).
- A common aspect of all the above student theories, the globes appear to receive the current at the same time, was influenced by their conceptions that

the human eye was inadequate to observe the effects of a high-speed sequential current.

- a ‘momentary unequal current sharing’ theory which states that the first globe receives the current before the second. When the current reaches the second globe, the amount of current in the first globe reduces to a final amount equals to that of the second globe. This momentary (1 second) current change accounts for the ‘observed’ initial brighter glow of the first globe for a second, which subsequently dims down to the same brightness as the second globe. (Dan S).
- a current-completed-journey condition theory which suggests a condition or a requirement to be fulfilled in the circuit for the simultaneous glow of the globes. That is the current must complete its journey around the series circuit before the globes are considered to have possessed electricity and hence accounts for the globes to glow at the same time (Sian).
- an ‘instant current’ theory with a tennis-balls-in-a-row analogy which states that the current flow in the circuit is analogous to a row of tennis balls; when one is pushed the rest move at the same time (Dan M, Simona and Bobby).

Moreover, one also could infer that the light globes POE was effective in diagnosing how students applied their ontological understanding of electric current to respond to contradictory observations (globes glowed simultaneously) by rejecting the validity of their observations, reinterpreting using their existing theories, making peripheral change to their existing theories, changing their existing theories completely or simply acknowledging their inability (impasse) to explain their observations.

The Skills of the Teacher/Researcher Who Used POEs

While written POE responses of students provided much data for analysing students’ ontological understanding of the electric current and how they responded to their contradictory observations, insights into students’ understanding also were dependent on the teacher/researcher’s pedagogical skills in his use of POEs.

First, the teacher/researcher needed to conduct effective interviews based on students' written POE responses. The need for interviews was critical in obtaining insights into students' understanding when their written responses did not provide adequate information. For instance, in the second light globes POE, students like Dan M., Bobby and Simona did not provide any explanation for their observations prior to being interviewed. Analysis of their interview data revealed that they were able to use an 'instant current' theory based on a tennis-balls-in-a-row analogy to explain their contradictory observations.

Second, the teacher/researcher needed to be able to design POEs that produced simple and straight forward observation outcomes (relative brightness or simultaneous glow of the globes) to diagnose understanding of the more advanced students, namely, Grade 11 and 12 students, on their existing conceptions of electricity. Data analysis of the first light-globes POE showed that even these advanced students (for example, Susan, Kerwin and Christian) were not able to differentiate between current, voltage, watt and power. Moreover, their understanding of the electric current was one of 'high speed sequential in nature' that produced effects that could not be detected by the human eye. Their understanding was in sharp contrast to the scientist's model of instant current.

In short, it was not just the POEs that were effective in diagnosing students' understanding; it was also the pedagogical skills of the user, which was undergoing development in the course of this research that enabled him to use the POEs effectively.

Summary of Chapter 6

The purpose of this part of the study described in this chapter was to elucidate the effectiveness of POE tasks in diagnosing students' existing knowledge and how their existing knowledge influenced their responses to contradictory data by using a specific case (electricity) of Research Question 2: How effective is the Predict-Observe-Explain technique in diagnosing types of student responses to contradictory observations. Specifically, the immersing research questions addressed were:

1. How effective are POE tasks in diagnosing students' existing conceptions of electricity?
2. How effective are POE tasks in diagnosing how students' responses to contradictory data are influenced by their existing conceptions of electricity?

POEs, which produced a phenomenon that was clear, immediate and had only one aspect for students to observe, were demonstrated by the teacher to obtain information on students' understanding and responses. Students' existing conceptions of electricity were of a source-consumer sequential model and were applied to explain their contradictory observations in five ways, namely, insufficient power/electricity, globe-preserving, all power consumed by one particular globe, close proximity to the battery, and brightness being determined by the globe's specification power. As a consequence of the model, students failed to recognise the current conserved characteristic of the series circuit. Students also constructed further variations of their sequential model and applied them to respond to contradictory observations by rejecting the validity of their observations, reinterpreting using existing theories, making peripheral change to their existing theories, changing their existing theories completely or simply acknowledging their inability to explain their observations.

While written POE responses of students yielded much information on students' understanding of electricity, the effectiveness of POEs also was dependent on the pedagogical skills of the teacher/researcher, which was undergoing progressive development in the course of his research. That is, the ability to conduct effective interviews based on students' written POE responses and the ability to design POEs that produced observational outcomes that were clear, immediate and had only one aspect for students to observe to diagnose understanding of the more advanced students (Grade 11 and 12).

The next chapter will describe the effectiveness of POE tasks in obtaining credible information of individual students' epistemological and ontological beliefs and

understanding of science. And how such credible information obtained using POE tasks are effective in identifying students' level of achievement.

CHAPTER 7

DIAGNOSING STUDENTS' RESPONSES IN THE COURSE OF INSTRUCTION

Introduction

This chapter describes case studies of two students to demonstrate the effectiveness of POEs in diagnosing individual students' epistemological and ontological beliefs and understanding. It also describes how POEs can be used effectively by the teacher/researcher to profile an individual student's progress over time in terms of epistemological and ontological understanding and level of achievement.

For the purpose of data interpretation and analysis, students' epistemological understanding is interpreted using descriptors of Hewson and Hennessey (1992), while descriptors of Chi et al. (1994) and Duit (1995) are used to interpret ontological understanding. Students' level of achievement is interpreted using descriptors of the Science Student Outcome Statement (1998) of the Department of Education of Western Australia. Since the POEs used in this study involve contradictory phenomena, students' responses are interpreted using descriptors of Chinn and Brewer (1993).

Overview

In the previous chapter, POEs were found to be effective in obtaining quality information of students' existing knowledge and the way they responded to contradictory data. The effectiveness of POEs was also dependent on the pedagogical skills of the teacher/researcher in using POEs in his classroom and his ability to conduct effective interviews based on students' written responses.

This chapter describes the effectiveness of two pairs of globe-and-switch POEs (see Figure 6.1 in Chapter 6 and Figure 7.1) to diagnose individual students' epistemological and ontological understanding of science, electricity in particular. It

also describes how effective are the globe-and-switch POEs in identifying students' level of achievement, and in profiling students' progress over time.

The first pair of globe-and switch POEs described in chapter 6 was used to obtain information on how a class of students responded to contradictory observations. Data of one grade-10 student from this class is analysed, interpreted and described in this chapter on the effectiveness of POEs in diagnosing individual student's epistemological and ontological understanding and level of achievement.

To evaluate the effectiveness of POEs in enabling the teacher-researcher to profile students' progress over time, a second pair of POEs was designed. The first POE (Figure 7.1a) in this pair was used to obtain information on how a class of the students responded to contradictory observations and to diagnose their ontological understanding. The second POE (Figure 7.1b) was used to identify one student among the class who has progress most in ontological understanding over time.

Specifically, this chapter sought to answer the following research questions:

Research Question 3: How effective are POEs in diagnosing individual students' epistemological and ontological beliefs and understanding?

Research Question 4: How effective is the Predict-Observe-Explain technique in identifying students' level of achievement in terms of the Australian Student Outcome Statements?

Case Study 1: Diagnosing One Grade 10 Student's Epistemological and Ontological Understanding and Her Level of Achievement

Two POEs (Figure 6.1 Chapter 6) were designed to evaluate the effectiveness of POEs in diagnosing one grade 10 student's epistemological and ontological understanding, and in identifying her level of achievement according to the West Australian Science Student Outcome Statements (1998). These POEs were

administered to a class of 20 mixed grade (9 to 12) students in a local metropolitan high school.

The first POE responses of Becky, a grade 10 student, are described as follows. Becky was the most articulate of grade 10 students. While other students also provided substantial responses, it would have been less informative for inferring epistemological and ontological understanding and outcome level.

Two electric light globes (18W 6V and 3W 6V) function normally when each is connected to a 6-volt DC power supply. The globes are then connected in series to a 6-volt DC power supply (see Figure 6.1a of Chapter 6).

1. Predict which globe will glow brighter if the circuit is completed. State and explain the reason(s) for your prediction.

I think that the larger globe will glow brighter. The reason for this is because the direct current starts at the globe that is where there is more current than the smaller globe, which is where the current is returning back to the battery. There is also more watts so that could also cause a difference.

2. When the circuit is completed, which globe glows brighter? Describe your observation with regard to the relative brightness of each globe. State and explain the reason(s) for your observation.

When the circuit is complete, the smaller globe glowed brighter than the larger globe. The larger globe did not even glow. I am not 100% positive why but I think it had something to do with the placement of the globes but I think more the number of watts because there were 3 watts in the smaller globe the current when it passed through the larger globe increased the brightness of the globe.

3. Compare your observation with your prediction. Are there in agreement or disagreement? Explain with your reason(s).

No, they were not in agreement. What I thought would happen, didn't.

4. Discuss your answers to the above three questions in your group and write down your final reasons and explanation.

We all come up with the solution that the smaller globe should have been placed at the beginning of the current flow and the larger globe at the end of the flow. We think this will cause a difference in the result and cause both globes to light up.

Becky uses her idea of the bigger watt globe consuming more current and being the first to receive the current to account for its brighter glow during the prediction part of the POE. This part of her POE response indicates a sequential current consumed ontological model, which is further evident in the following interview transcript excerpt:

Teacher: Why is the current through the larger globe more than the smaller globe?

Becky: Because of the greater watt and I thought that the larger globe would light up more... the current will flow through like this way (towards 18W globe) so light up this one (18W globe) then like whatever is left over will light up ...(unclear) and keeps on going round.

When her observation (only the 3W globe lights up) contradicts her prediction, she did not change her view and explained, 'it had something to do with the placement of the globes.' She was still holding on to her sequential current consumed model, which is further evident by the following interview transcript excerpt:

Teacher:... in your observation in question 2, you notice that the smaller globe glowed but not the larger one. Although you are not 100% positive, but you think that it has something to do with the placement of the globes. Can you elaborate more on that?

Becky: Well, cause the smaller globe fills up first, like lit up brighter, I thought that may be if the smaller globe is placed first and then the larger globe that the larger globe would have then lit up brighter, may be.

Teacher: Why do you think so?

Becky: Because like the smaller one even though 3W still lit up brighter than the 18W globe so I thought well, if the smaller globe first that is 3W, thought, because in my prediction I thought that it (the larger globe) would lit up brighter because it is so much greater in watt that the current will have been used up to light up that one. So thought well if the 3W first and then the 18W, may be the 18W would light up as well.

Her view is that the smaller globe being small in watt (3W) needs less current to light up than the larger watt globe (18W). By allowing a sequential current to flow through it first, there would be more left over current for the bigger watt globe to consume. The left over current may be sufficient to light up the bigger watt globe. Her epistemological commitment of her theory does not seem strong as indicated by her statements, like 'I think' and 'I am not 100% positive.'

To further ascertain this student's ontological and epistemological view of the electric current, a POE using two globes of equal power specification (18W 6V) was used. Two electric light globes (18W 6V) function normally when each is connected to a 6-volt DC power supply. The globes were then connected in series to a 6-volt DC power supply (see Figure 6.1b of Chapter 6).

1. Predict which globe will receive current first and which one will receive more current if the circuit is completed. State and explain the reason(s) for your prediction.

I think that the 18W globe no.1 will receive the current first because it is at the beginning. It is the first globe in the circuit but the second globe will glow the same amount or brighter cause the last globe in the circuit.

2. When the circuit is complete, which globe is the first to receive current and which one receives more current? Describe your observation. State and explain the reason(s) for your observation.

The globes both light up at the same time but the first one probably light up first because it is at the beginning/first in the circuit. I am not 100% sure because it was too quick for the human eye. And they both receive the same amount of current, which, is 1.7 amps. The reason for this is I think because they are of equal watts and volts therefore they will be the same amps.

3. Compare your observation with your prediction. Are they in agreement or disagreement? Explain with your reason(s).

They are in agreement and disagreement. What I thought would happen could have happened but was too quick for the eye to see and I also said that the second globe would glow the same amount but then it went into disagreement which when I said 'or brighter cause the last globe in the circuit.'

4. Discuss your answers to the above three questions in your group and write down your final reasons and explanations.

Our group had the same idea of which the first globe light up first but was undetectable by the human eye and they were of equal amps.

Becky demonstrated that the idea of electric current is something that flows sequentially. Using the descriptors of Hewson and Hennessey (1992, p. 177), this student's conception is intelligible because she was able to describe it in her own words to make prediction and interpretation for her observation of the phenomenon. She knows what the concept means from her viewpoint. This is indicated by her prediction statement response '...globe no.1 will receive the current first because it is at the beginning...' and by her observation response statement '... the first one probably light up first because it is at the beginning/first in the circuit.' To this

student, the idea of the super-speed sequential current is plausible because it fits in with her picture of the world, namely, the positions of globes in the series circuit. Statements like ‘...It is the first globe in the circuit...’ and ‘...it is at the beginning/first in the circuit,’ are further reinforced during the reconciliation part (question 3) of the POE. Her reinforcement statement, ‘They are in agreement ...what I thought would happen could have happened but was too quick for the eye to see.’ indicates that she believes this is how the world actually is.

Becky’s super-speed sequential current theory is fruitful to her because she is able to use it to explain her apparent contradiction between her prediction and observation of the phenomenon. Her super-speed sequential current theory influenced her observation. Although, she accepts her observation (both globes light up at the same time) she does it with reservation indicated by her epistemological comment ‘I am not 100% sure’. She reinterpreted (Chinn and Brewer, 1993) her observation by arguing that the sequential current flow ‘was too quick for the human eye’. Furthermore, her epistemological commitment of her theory was further echoed during her group discussion which led her to make this comment: ‘Our group had the same idea of which the first globe light up first but was undetectable by the human eye’. This super-speed sequential current theory is also indicated by her in-class journal statement, ‘I also learnt that positioning matters and that the first globe would light up first even though it is undetectable by the human eye.’ The data suggest that Becky does not see cognitive conflict, at least entirely in the same way as the teacher/researcher, whose intention is to promote the scientist’s conception of an instantaneous current to account for the simultaneous lighting of globes in a completed circuit.

Ontologically speaking, Becky views current as something that has quantity and it flows. This is indicated by her matter-based predicates, equivalent words or phrases articulated (Chi et al., 1994) in her POE responses on the subject of current. These predicates are ‘globe no.1 will receive the current first’, and ‘both globes receive the same amount of current which is 1.7 amps.’ And this matter called current has not only the properties of quantity and flow, but also it has the attribute of flowing at a super speed as indicated by the predicates like ‘too quick for the human eye’ and

'was undetectable by the human eye.' Her further ontological electric current consumed model (used in her earlier POE) enables her to explain her observation of both the ammeters giving the same reading (1.7A). That is 'both receives the same amount of current ...because they are of equal watts and volts...' The data indicate that neither the simultaneous lighting of the globes nor the same reading on the ammeters convince this student that the scientist's instantaneous current and current conserved model is the more appropriate explanation of the phenomenon observed.

However, the data suggest that POE's are effective in diagnosing Becky's ability to apply her own ontological and epistemological understanding to explain specific events and phenomenon, namely, the relative brightness of the globes, their simultaneous lighting up and same reading on each ammeter. Furthermore, the data also suggest that POEs are effective in identifying the student's ability to reinterpret her observation and data that are contradictory to her prediction of the phenomenon. This student is able to argue conclusions during the POE activities on the basis of collected information (reading of ammeters), personal experience (simultaneous lighting of globes) and her own theory (super-speed sequential current consumed model). Her level of achievement identified here corresponds to level eight of the 'investigating scientifically' strand and the 'processing data' substrand of the Science Student Outcome Statements (1998) of the Department of Education of Western Australia. Using descriptors of the Science Student Outcome Statements (see page 25), Becky was able to 'account for anomalous observations when interpreting data'. Specifically, her level of achievement identified here corresponds to level IS 8.3. Although her arguments for her conclusions of 'first globe receives current first' and 'both receive the same amount of current' are incongruous to that of the scientist's, she did propose possible arguments that fit her own ontological and epistemological understanding of the phenomenon. Furthermore, written responses to Question 3 and 4 on her POE experiment worksheet reveal her ability to communicate her observation and make suggestions (using her own ontological view) about what her observations mean. This suggests that she also has achieved at level IS 1.3 (students tell what they observed) and IS 2.4 (students can comment on what happened and can say whether what happened was expected) of the 'investigating scientifically' strand and the 'processing data' substrand of the Student

Outcome Statements (p. 21). Becky had also achieved at level IS 3.1(see page 22) as demonstrated by her ability to make simple prediction based on her personal theory and past experience. The data suggest that POEs allow this student to demonstrate achievement across levels within a strand and substrand and enable the teacher/researcher to observe and document a spread of achievement over a range of levels rather than a single outcome.

Case Study 2: Profiling Students' Progress Over Time Using the Globe-and-Switch POE

To evaluate the effectiveness of POEs in enabling the teacher- researcher to profile a student's progress over time, the following pair of POEs was designed. These POEs were administered to the class of 17 mixed year students (grade 9-12). Consequently, complete analysis of the learning from the globe-and-switch POEs shown in Figure 7.1 by the whole class is presented.

Globe-and-switch POEs

An electric light globe (18W6V) that functions normally is connected to a dry cell (3.0V) and switch as shown in Figure 7.1.

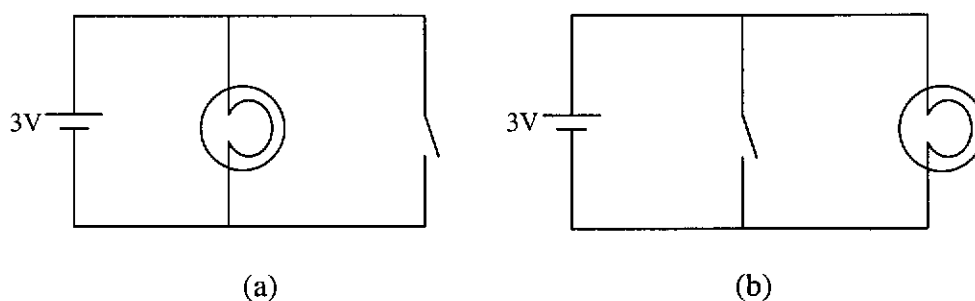

Figure 7.1 Globe-and-switch POE 1 and 2 circuit diagrams

1. Predict what will happen to the globe if the switch is turned on. State and explain the reason(s) for your prediction.
2. When the switch is turned on what happened to the globe? State and explain the reason(s) for your observation.

3. Compare your observation with your prediction. Are they in agreement or disagreement? Explain with your reason(s).
4. Discuss your answers to the above three questions in your group and write down your final reasons and explanation.

The first POE (Figure 7.1a) was used to obtain information on how the class responded to contradictory observations and to diagnose ontological understanding. Results of data analysis of the class of 17 students are described as follows.

Table 7.1. Predictions and observations of the mixed year class (n=17, Grade 9-12)

Observed	Predict	
	Globe will light up	Globe will not light up
Globe did not glow	13	4
Globe did glow	0	0

Students' observations compared to their predictions on as to whether the globe would glow are presented in Table 7.1. Of the 17 mixed year students, 13 predicted that the globe would glow and 4 students predicted that the globe would not glow. All 17 students observed that the globe did not glow when the switch was turned on. The data suggest that the POE designed was able to produced immediate, obvious, and clear observation outcome as there were no variations in students' observations. Furthermore, the data also suggest that the POE is effective in diagnosing types of students' responses to contradictory observations and that results of data analysis on the type of students' responses presented on Table 7.2 are credible, valid and plausible.

Table 7. 2. Features of each of response type to anomalous observations (n=17)

Type of response	Features of the response		
	Does the student accept the data?	Does the student explain the data?	Does the student change theory?
Accepting new data but unable to solve the problem			
Reinterpret (6) Joshua, Dan S., Amy, Becky, Briony, Sian,	Yes	Yes but wrong	Yes/modified
Acknowledge impasse (6) May, Nicole, Nat, Kama, Dan B., Dan M.	Yes	Maybe	No
Peripheral theory change (5) Susan, Kerwin, Rob, Harmony, Sheila,	Yes	Yes	Yes, partly

Table 7.2 presents a summary of the results of data analysis of the 17 mixed year students using the framework adapted from Chinn and Brewer (1993, 1998). Although all 17 students observed that the globe stopped glowing when the switch was turned on, they responded differently to the contradictory observation. Specifically, while all students accepted the contradictory data, 6 of them reinterpreted their observation, 6 students acknowledged their inability to explain their observation, and 5 students changed their existing their theory peripherally to explain their observation.

A case-by-case data analysis was conducted to obtain information on students' ontological understanding. Results of this data analysis are described as follows.

Reinterpreting (n=6)

Joshua seems to use a 'current cancellation' theory to explain both his prediction (the bulb would not glow) and his observation (the globe did not glow). That is when the switch is turned on the circuit design causes the current that went around the switch to 'interact' with the current that went through the bulb resulting in current cancellation. Similarly, Sian also uses her 'current interfering' theory to explain her contradictory observation as indicated by the following excerpts:

1. Joshua (Grade 11)

Prediction: The globe will not work...(the circuit will cause the current to cancel out).

Observation: The globe switched off. ...I think the current went around the bulb and interacted with the current that went through the bulb, which caused a cancellation.

2. Sian (grade 10)

Prediction: ...the globe will turn on and light up. ...because the power from the dry cells will cause the globe to turn on.

Observation: Before the switch was turned on the globe was glowing but as soon as the switch was turned on the globe stopped glowing. ...because it interferes with the first current.

While Joshua and Sian uses a 'current cancellation' theory, Dan S. and Amy uses a 'power-cut-off' theory to explain their contradictory observation as indicated by the following excerpts:

3. Dan S. (Grade 11)

Prediction: The light globe will glow to its maximum brightness and then it will blow. ...The power will overheat the tungsten, and then the tungsten will break.

Observation: The light globe glowed until the switch was turned on, then the globe didn't glow at all. ...The switch cut off the power supply so the power would avoid going through the globe.

Interview:

Teacher: Dan, in your observation you explained that the globe did not glow because the switch cut off the power supply. Will you draw for me a diagram to indicate where the power supply would go?

Dan S.: (His diagram, indicated a path through the battery and the switch with no supply through the globe.

4. Amy (Grade 11)

Prediction: ...globe will not glow. Because the electrical current will flow around and will not go to the globe.

Observation: The globe went on... but when the two wires [representing the switch] were connected the globe when off. ...Because when the battery touched the globe the switch was turned on and when the rest of the circuit was connected

the switch was turned off.

Dan S's written response suggests that the switch created a 'power cut off' to the globe. In an interview, he elaborated his theory that describes an alternative path through the switch allowing no power supply to the globe. Similarly, Amy's written response reveals an 'alternative path' theory where the current 'flows around and not go to the globe'.

Instead of using an 'alternative path' theory Becky and Briony seem to use an 'on-off' theory where the globe is turned off when the switch is turned on as indicated by the following excerpts:

5. Becky (Grade 10)

Prediction: ...the globe will light up. Even though this circuit is not a series circuit, it is a parallel circuit; the globe being placed in the middle does not make any difference. Another thought that came into my mind was that because the number of volts in 2 dry cells is 3V and the globe is 6V, I also thought it wouldn't light up because of that reason.

Observation: When the wires were firstly attached to the batteries the light globe light up, when the remaining wires were touching each other the globe didn't light up. This happened because when the wires were attached to the battery the circuit was turned on, and when the remaining wires were attached the globe was turned off.

6. Briony (Grade 9)

Prediction: I believe the light will turn on. This is because there is enough voltage and watts to light the globe.

Observation: When the switch is not on, the light turns on, when you turn the switch on the light goes off. ...Because the wires coming from the battery were both positive, and when they were joined the current stopped.

Apparently, these students recognized that the globe would glow before the switch was turned on due to a current flow to the globe. The current flow was due to the parallel circuit design (Becky's reason) and sufficient 'voltage and watts' to light the globe.

Acknowledging impasse (n=6)

The following 6 students acknowledge their inability (impasse) to explain their contradictory observation as indicated by the following excerpts:

1. May (Grade 12)

Prediction: The light will light up because electricity will come from two batteries and light up the globe... it will light up twice as bright.

Observation: When the switch was turned on the light was turned off. I don't know why this happens. That was a surprise.

2. Nicole (Grade 11)

Prediction: ...the globe will light up. Because even though the globe is in the middle of the circuit, it is still part of the circuit (parallel circuit). The current still flows.

Observation: ...the globe went from on to off. I have no idea why, but I'll guess that it was because the circuit was broken.

3. Nat. (Grade 10)

Prediction: ...the globe will light up when the switch is turned on. ...The energy from the two dry cells will cause it to light up.

Observation: ...the globe was already glowing before the switch was turned on. After the switch was turned on the globe went out.

Question 3 response: My prediction was completely different from what I observed. I'm not exactly sure why the globe went off...

4. Kama (Grade 9)

Prediction: ...the globe will light up as normal.

Observation: When the switch turned on the globe turned off. I really don't know the reason for this. It is strange that this happened.

5. Dan B. (Grade 10)

Prediction: ...The globe will light up when switched on. Because (no further response).

Observation: ...the globe did not glow...(no further response).

6. Dan. M (Grade 10)

Prediction: ...the light globe will not light up, because it is a surprise circuit. The reason why I think that is because of the way it is set up.

Observation: The globe was already alight and when we turned the switch on the light was turned off.

They all expressed that they 'don't know', 'have no idea why', 'not sure why' or did not provide any explanation for their contradictory observation.

Peripheral theory change (n=5)

The next 5 students made a peripheral change to their initial theory to explain contradictory observation as indicated by the following excerpts:

1. Susan (grade 12)

Prediction: It will light up. ...The switch will make a complete circuit.

Observation: It was already lit up, then, it turned off. ...Because it was a parallel circuit. Similar to that of a circuit with two light switches, that is in a stairway.

2. Kerwin (Grade 11)

Prediction: I think the light globe will not glow at all because the circuit is not connected in series. It is a parallel circuit!

Observation: ...the globe did not glow at all after the switch was turned on. The reason was that ...the circuit was a parallel circuit. Before switched on, the globe was alight (the circuit was complete).

3. Rob (Grade 10)

Prediction: ...the light globe will light up because the electricity will run through all wire and the globe is connected to wires so it will light up.

Observation: The globe didn't light up because the electricity was converted through only the outside wires.

4. Harmony (Grade 10)

Prediction: ...the light globe will turn on before the switch is turned on or connected. This will happen because there is still a closed circuit between the cells and the globe.

Observation: When the switch was turned on the globe went off. I think that this happen because the current started traveling through the larger closed circuit instead of the smaller one where the globe was. i.e. (diagrams drawn to show current only flows through the circuit with the switch).

5. Sheila (Grade 9)

Prediction: I think that the globe will light up. This is because pressure is applied to the circuit but cannot get through until the switch is turned on to complete the circuit.

Observation: When the switch is turned on the light globe turned off! This is because without the switch on the globe was already on, because it was a full circuit. However, when the switch was turned on electricity took the easiest way and went the way without the globe.

All these students recognised a complete circuit current flow that allows the globe to glow initially before the switch was turned on. Then with the switch turned on they observed that the globe stopped glowing and explained that the current was flowing through an alternative circuit that has the switch. Their reason being that the alternative circuit is an 'easiest way' or it is a parallel circuit. These students changed

their complete circuit theory peripherally to an 'alternative circuit' theory.

To evaluate the effectiveness of POEs in enabling the teacher-researcher to profile students' progress over time, the second POE (Figure 7b) was administered to the same mixed grade class in this research. Specifically, this POE was administered to diagnose any change in students' understanding of current flow in a parallel circuit. Data obtained using this POE and that of the first POE were used to identify a student who had progressed most in her understanding of electricity in a parallel circuit. The student identified was Sheila, a grade-9 student.

An Analysis of Sheila's Response to the Globe-and-Switch POEs

Results of data analysis on her first POE responses is described as follows:

An electric light globe (18W6V) functioning normally is connected to a dry cell (3.0V) and a switch as shown in Figure 7.1a

1. Predict what will happen to the globe if the switch is turned on. State and explain the reason(s) for your prediction.

I think that the globe will light up. This is because pressure is applied to the circuit but cannot get through until the switch is turned on to complete the circuit. In this case this is what happened.

2. When the switch is turned what happened to the globe? State and explain the reason(s) for your observation.

When the switch is turned on the light globe turned off! This is because without the switch on the globe was already on, because it was a full circuit. However, when the switch was turned on electricity took the easiest circuit or way and went the circuit without the globe.

3. Compare your observation with your prediction. Are they in agreement or disagreement? Explain with your reason(s).

My observation is in disagreement to my prediction. This is because I did not recognise that it was already a complete circuit and that the switch would turn it off.

4. Discuss your answers to the above three questions in your group and write your final reasons and explanations.

The electricity took the easiest route when the switch was turned on which was to go straight and not light up a globe.

It should be noted that the circuit was not set up until students were asked to answer question 2. Sheila did not recognize the pre-existing circuit of the globe until the circuit was actually set up. The reason for her observation (the globe stopped glowing) was that 'electricity took the easiest way and went the circuit without the globe.' When interviewed, her answer to the question 'Was there electricity going through the globe when the switch was turned on?' was no. She was also asked to draw a diagram of the circuit showing the path of current as shown in Figure 7.2.

Sheila's view of current as something that flows through the easiest route is a matter-based ontological category. Moreover, she did not realise that the easiest route is a path of least resistance and the globe being a metal conductor, although having a much higher resistance than the switch, would still have some current flowing through it, until during the class discussion. The following excerpt of her in-class journal indicates this:

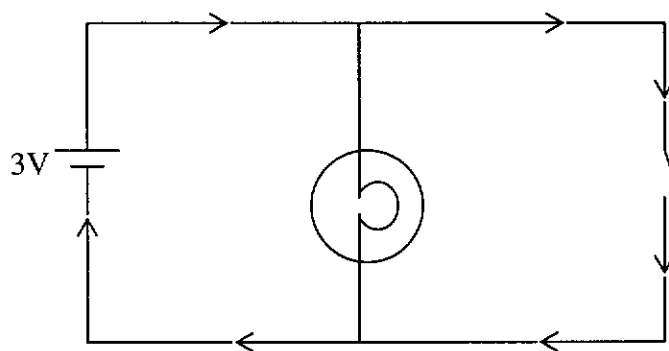

Figure 7.2 Sheila's circuit diagram 1

...because current always took the easiest route. However I did not know why current did this. Today's class discussion revealed to me that current took the easiest route because current flows through path of least resistance and the globe is resistance. This immediately got me thinking that the globe wires had no current but one of the class members pointed out that all metal conducts therefore the wire had to have current.

Her in-class journal also suggests that Sheila was able to evaluate her conclusion on her observation (switch turned on, the globe turned off). Specifically, she was able to discuss the influence of her prior understandings of the current taking the easiest route through the switch that led her to conclude that there was no current flowing through the globe. She now realises the limitation of her conclusion. Using 'Student Outcome Statements' descriptors, Sheila was demonstrating achievement at level eight (IS8.4) of the 'evaluating' substrand in the 'investigating scientifically' strand. Sheila was able to reflect and evaluate her existing theory of 'no current flowing through globe' using the idea of 'all metals conduct electricity' generated during class discussion. During the interview Sheila was able to describe her observation and draw a circuit diagram (Figure 7.2) to represent what she thought (the direction of current flow) was happening. The interview data indicate that Sheila was achieving at outcome level one (IS 1.3) of the 'processing data' substrand.

Analysis of Sheila's written responses to this first light globe POE also reveal a number of other outcome achievements. First, Sheila was able to evaluate her

prediction by commenting on whether what happened was expected as indicated by her question 3 response, 'My observation is in disagreement to my prediction. ...I did not recognize that it was already a complete circuit...' and the switch would turn it [globe] off.' This response of Sheila's, indicates her achievement at level two (IS2.4) of the 'evaluating' substrand. Second, Sheila was able to account and respond to her anomalous observation ('...the light globe turned off.') by accepting and interpreting data using her 'easiest route in full circuit' theory. She seems to have made a peripheral change to her prediction theory of 'current only flows through a closed circuit' to a modified theory where current would flow through the easiest route when there is more than one closed circuit to account for and interpret her anomalous observation. This peripheral theory change is evident in her question 2 response, 'electricity took the easiest way and went the circuit without the globe.'

Using 'Students Outcome Statements' descriptors Sheila was achieving at level IS8.3 of the 'processing data' substrand within the 'investigating scientifically' strand, which states that 'The student identifies anomalous observations...' In relation to this outcome, a pointer on page 25 provides an illustrative description of a way in which Sheila has demonstrated the outcome. According to this pointer, a student's ability to 'account for anomalous observation when...interpreting data is an evidence of achieving at outcome level IS8.3. Third, Sheila was able to evaluate her theory in terms of the data (globe didn't glow) leading to changing her theory of 'current flows through easiest route only' to 'current flows through all completed circuits.' during class discussion. There is a development of her theory, namely, 'easiest route is route of least resistance.' Sheila also was achieving at outcome level IS6.3 of the 'processing data' substrand.

In short, this POE coupled with a teacher-led class discussion has facilitated critical analysis of a scientific investigation to help Sheila to develop, change and expand her personal pre-instructional theory to a more powerful one to explain her anomalous observation. At this stage there is no indication in the data that Sheila's theory is a 'circuit-divide-at-junction' theory where a larger resistor carries a lesser fraction of the total current.

To track and identify Sheila's progress, a second POE similar to the first was administered a week later to the class. Sheila's responses to this POE is described as follows:

An electric light globe (18W6V) functioning normally is connected to a dry cell (1.5V) and a switch as shown in Figure 7.1b

1. Predict what will happen to the globe if the switch is turned on. State and explain the reason(s) for your prediction.

The globe will turn off. This will happen because in the beginning the light will be on therefore current is flowing through. When the switch is turned on the globe will turn off because the current will divide at the junction and the new amount of current flowing through the globe will not be enough to light it up.

2. When the switch is turned on what happened to the globe? State and explain the reason(s) for your observation.

When the switch was not on the light was lit up and the reading (ammeter) was 1.5 amps. When the switch was turned on the globe turned off and the reading went down to 0.6 amps. I think that the other 0.9 amps went to the wire with the switch and the light did not turn on because 0.6 is not a sufficient amount of amps to light up the globe.

3. Compare your observation with your prediction. Are they in agreement or disagreement? Explain with your reason(s).

My prediction and observation are in agreement with one another. In my prediction I said that the amps would divide and go to the two wires when the switch was turned on. This I believe is what happened.

4. Discuss your answers to the above three questions in your group and write down your final reasons and explanations.

The group I was in was on the average in agreement with what I had, and we all realized that the globe went out when the switch was turned on because the current took the easiest route away from the resistance.

Sheila has now demonstrated her ability to apply two characteristics of parallel circuits to make her prediction and interpret her observation of the phenomenon, namely, the total current in the circuit divides among the parallel branches, and total current in the circuit equals the sum of the current in the parallel branches. This is indicated in her prediction response statement 'the current will divide at the junction and the new amount of current flowing through the globes will not be enough to light it up.' Also she was able to account for her observed drop in the ammeter from 1.5A to 0.6A, by a mentally computed amount of 0.9A current that went through the switch branch.

Epistemologically speaking, her conception is intelligible, plausible and fruitful. She was able to describe the two characteristics of parallel circuits in her own words like 'divide at the junction' (Question 1 response) and she believes how the world actually is (see criteria for intelligibility by Hewson and Hennessey in chapter 2 on page 47). That is 'the amps could divide (Question 3 response). This I believe is what happened.' Sheila was also able to use her conception to explain why the globe did not glow. This is indicated by her observation statement 'the reading went down to 0.6 amps... is not sufficient amount of amps to light up the globe.' Ontologically speaking, her understanding of a characteristic of parallel circuits is that the total current 'divide at the junction' and is equal to the sum of the current in its parallel branches (the observed 0.6A through the globe and the calculated 0.9A through the switch.) Using Duit's (1995) ontological descriptors, Sheila has the concept of the total circuit current being divided due to a feature of the parallel circuit, namely the parallel branches, at their junction. Specifically, the resistance of each parallel branch is the ontological feature that Sheila uses to explain her observed current reduction through the globe. The following interview transcript excerpt indicates this:

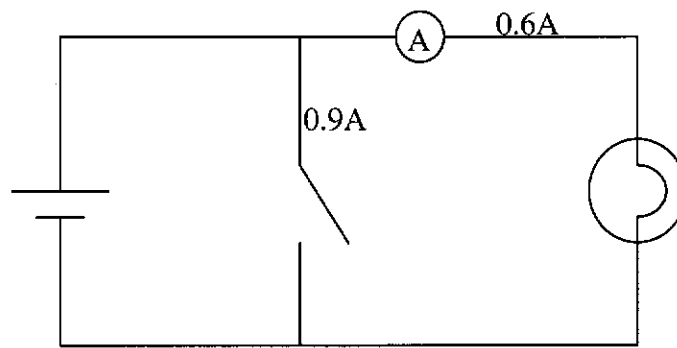

Figure 7.3 Sheila's circuit diagram 2

Teacher: Looking at the diagram that you have just drawn (Figure 7.3), why does the 0.9A (current) went to the wire with the switch?

Sheila: Um... Because that doesn't have as much a resistance because it doesn't have a light globe, the electrons take the easiest route and so more go that way (pointing at the switch).

Teacher: Which way did more current go?

Sheila: Um... went through where the switch is.

Sheila views that the lesser resistance branch receives more current. Using Chi et al.'s (1994) descriptors, Sheila's view of current is a matter category that has quantity. This is indicated by the matter-based predicate 'electrons take the easiest route and so more go that way (pointing at the switch).' Further indication of her matter-based category is observed in her prediction predicate 'new amount of current... will not be enough to light up.' And in her observation predicate '0.6 is not a sufficient amount of Amps to light up the globe.' The data suggest that POEs are effective in eliciting useful information on students' conceptual understanding epistemologically and ontologically.

Furthermore, POEs are also effective in facilitating the teacher's observations of students' achievement and profiling of progress overtime. First, Sheila was able to recount sequences of connected events like 'when the switch is turned on the light globe turned off' which correspond to a level one (IS1.2) achievement of the

'conducting' substrand in the 'investigating scientifically' strand of the 'Student Outcome Statements.' Second, Sheila demonstrated her ability to compare her conclusion of her prediction with her observation. Her question three statement such as 'My prediction and observation are in agreement...' indicates this. Furthermore, she was able to compare her results and conclusion with those of other students. Her question four statement indicates this '... we all realised that the globe went out... because the current took the easiest route away from the resistance.' Sheila was able to comment on what happened and say whether her observation was expected or different from her prediction. She also was able to evaluate her prediction and observation in terms of her existing theory (current took the easiest route away from the resistance). Using student outcome descriptors, Sheila's achievement corresponds to a level two and eight (IS2.4 and IS8.4) of the 'evaluating findings' substrand in the 'investigating scientifically' strand.

Third, Sheila showed her ability to predict the light intensity of the globe using the relative resistance of the parallel branches as a condition for current division. She was using her scientific knowledge to make an accurate prediction and thus her achievement corresponds to level six (IS6.1) of the 'planning' substrand of the 'investigating scientifically' strand. Fourth, she used her conception to relate observed changes in the ammeter readings to changes in the amount of current received in each parallel branch. Sheila was achieving at level seven (IS7.3) of the 'processing data' substrand because she was able to explain her observation in terms of her scientific knowledge (current-divide-at-junction theory) and draw a conclusion (current divides), which was consistent with the data (her observed changes in the ammeter reading). The data suggest that POEs allow the student to demonstrate changes in her achievement across substrands over time and provide opportunity for her to document the way she developed her ideas.

Reflection

In this part of the research, the focus of data collection was on an individual student. The data suggest that POEs can be effective in diagnosing the student's ability to apply her own ontological and epistemological understanding to explain specific

events and phenomenon, namely the relative brightness of globes, their simultaneous lighting up and similar reading on each ammeter. Furthermore, the data suggest that POEs are effective in identifying the student's achievement across levels within a substrand of the Australian Student Outcome Statement and enable the teacher/researcher to observe and document a spread of achievement over a range of levels rather than a single outcome.

This part of the research also focused on an individual student to trace her progress over time. The data obtained suggest that POEs are effective in eliciting useful information on students' conceptual understanding epistemologically and ontologically that are incongruous and congruous to that of scientists'. The teacher can use information obtained as a basis to design a subsequent POE to track the student's progress over time. The initial information and subsequent data obtained suggest that POEs are effective in facilitating the teacher's observations of the student's progress over time. Furthermore, the data indicate that POEs provided the opportunity for the student to demonstrate changes in her achievement across substrands over time, and also provided opportunity for her to document the way she develops her ideas.

Summary of Chapter 7

The purpose of this part of the study described in this chapter was to elucidate the effectiveness of POEs in diagnosing individual student's epistemological and ontological understanding of science. It also describes how effective are POEs in identifying students' level of achieving and in profiling students' progress over time. The research questions address were:

Research Question 3: How effective are POEs in diagnosing individual student's epistemological and ontological beliefs and understanding?

Research Question 4: How effective is the Predict-Observe-explain technique in identifying students' level of achievement in terms of the Australian Student Outcome Statement?

The data obtained suggest that POEs are effective in diagnosing individual student's ability to apply her own ontological and epistemological understanding to explain specific phenomena. POEs are also found to be effective in identifying students' level of achievement over a range of levels within a subtrand of the Australian Student Outcome Statement. Furthermore, POEs are effective in facilitating the teacher's observation of students' progress over time.

CHAPTER 8

SUMMARY OF THE THESIS

Introduction

This research came about because of the author's interest in improving students' learning of science in his own classroom using a number of teaching strategies. His initial experience using the POE teaching technique informed him about some aspects of students' learning and understanding of science. First, students' observations of natural phenomena in science were influenced by their prior knowledge and beliefs and hence hindered their new learning. Second, students' explanations for their predictions and observations were personal constructions using their background knowledge. Third, their personal construction process is active and continuous. Fourth, students' personally constructed ideas were different from scientists' or what was taught in the classroom.

A preliminary review of literature on students' preinstructional knowledge indicated that their knowledge was firmly held, often persists despite instruction and were unrecognised by teachers. Studies on instructional strategies that were designed to change their preinstructional theories, using observations that were anomalous or contradictory to their predictions indicated that students tend to discount their observations in many ways, thus preserving their preinstructional theories.

Although, the POE technique has been used in schools to investigate students' understanding of science, its effectiveness in obtaining credible and quality information on students' science understanding is still an open question.

Overview of the Scope of the Thesis

This chapter describes the findings on the effectiveness of POEs in diagnosing students' understanding of science and in identifying their level of achievement. The sample comprised students in classes from three Australian metropolitan schools in grades 9, 10, 11, and 12 whose age ranges between 14 and 17 years. This research

employed an interpretive action research approach. Three data collection methods were used to generate data for interpretation, namely, written POE responses of students, in-class journals and student interviews. For data interpretation, three theoretical perspectives were used, namely, Chi et al.'s theory of ontological categories, Hewson and Hennesey's conceptual change theory to determine epistemological status of students' conceptions of science, and Chinn and Brewer's model to classify types of students' responses to contradictory data. The purpose of using this methodology was to obtain in-depth understanding, a plausible and credible account of students' understanding of science and their level of achievement.

Major Findings

Research Question 1: How effective is the Predict-Observe-Explain technique in diagnosing students' understanding of science across mixed grade classes?

The efficacy of POEs in diagnosing students' understanding of science was demonstrated in a pilot study described in chapter 4. Students' understanding of science were common across grades, across mixed grade classes and were largely inconsistent with those of scientists. The POEs on expansion of water and solubility of salt produced data that demonstrated how students' prior knowledge affected their prediction, observation and interpretation of phenomena. Variations in students' observations suggest that uniform observation outcome may not be always assumed even for a well-designed POE intended to provide an immediate, obvious, and clear observation outcome. The data also suggest that POEs are effective in capturing a range of possible students' observations and prediction outcomes when worded in an open-ended format.

Research Question 2: How effective is the Predict-Observe-Explain technique in diagnosing types of students' responses?

The water-in-glass tubing POE described in chapter 5 revealed four types of responses to contradictory information: considering observations irrelevant, excluding data not fitting one's theory, accepting new data but unable to explain the

phenomenon using scientists' conceptions, and accepting new data and explaining the phenomenon using scientists' conceptions. The data analysis indicated that when a phenomenon has more than one feature for observation (example, small initial drop, followed by a large rise, in the water level), students tend to be more committed to focus on an aspect of the phenomenon (the subsequent rise in water level) that supported their predictions. This commitment of focusing on a more preferred feature of a phenomenon resulted in the way that some students were recording their observations, that is, they recorded an initial rise instead of an initial drop in water level (although both aspects of the phenomenon were observed). Therefore, Research Question 2, which sought to evaluate the effectiveness of POE tasks in diagnosing types of students' responses to contradictory observations was somewhat answered.

The realisation that when a POE task that produces a phenomenon that has more than one feature for observation, students tend to focus on one aspect that supports their predictions. Consequently, some students were committing faulty experimental procedures that affected their observations of the intended phenomenon. This finding gives rise to the need to design POEs that produced phenomena that were immediate, clear and had only one aspect for students to observe. Moreover, POEs need to be administered by teacher demonstrations rather than by the students. To fulfil these designing and administering requirements for POEs to obtain more credible data, two electric circuit POEs were designed and administered to answer two emerging research questions that follow research question 2.

Emerging Research questions:

- 2.1 How effective are POE tasks in diagnosing students' existing conceptions of electricity?**

- 2.2 How effective are POE tasks in diagnosing how students' responses to contradictory data are influenced by their existing conceptions of electricity?**

The two electric circuit POEs described in chapter 6 revealed that conceptions of electricity were of a source-consumer sequential model and were applied to explain their contradictory observations in five ways, namely, insufficient power/electricity, globe-preserving, all power consumed by a particular globe, close proximity to battery, and brightness being determined by the globe's specification power. As a consequence of the model, students failed to recognise the current conserved characteristic of the series circuit. Students also constructed further variations of their sequential model and applied them to respond to contradictory observations by either rejecting the validity of their observations, reinterpreting using existing theories, making peripheral change to their existing theories, changing their existing theories completely, or simply acknowledging their inability to explain their observations.

While written POE responses yielded much information on students' understanding of electricity, the effectiveness of POEs also was dependent on the teacher/researcher's skills in conducting effective interviews based on students' written responses.

The results of data analysis described in chapter 5 and chapter 6 shows that POEs were effective in obtaining quality information of students' existing knowledge and the way they responded to contradictory data. Therefore, research question 2 and the two subsequent emerging research questions were answered.

Research Question 3: How effective is the Predict-Observe-Explain technique in diagnosing individual students' epistemological and ontological beliefs and understanding?

This part of the research described in Chapter 7 focuses on data collection on individual students for two case studies. The first case study, a grade-10 student, reveals that POEs can be effective in diagnosing the student's epistemological and ontological beliefs and understanding of science, and her ability to apply her own understanding to explain specific events and phenomenon, namely the relative brightness of globes, their simultaneous lighting up and similar reading on each ammeter.

Research Question 4: How effective is the Predict-Observe-Explain technique in identifying students' level of achievement in terms of the Australian Student Outcome Statements?

The data suggest that POEs are effective in identifying the student's achievement across levels within a substrand of the Australian Student Outcome Statement and enable the teacher/researcher to observe and document a spread of achievement over a range of levels rather than a single outcome.

This part of the research focussed on an individual grade-9 student in order to trace her progress over time. The data obtained suggest that POEs when used in a series are effective in eliciting useful information on the student's conceptual understanding, both epistemologically and ontologically, that are both incongruous and congruous to that of scientists. The initial information from the first POE enabled the teacher to design a subsequent POE to track the student's progress over time. The data collected suggest that POEs are effective in facilitating the teacher's observations of the student's progress over time. Furthermore, the data indicate that POEs provided the opportunity for the student to demonstrate changes in her achievement across substrands over time, and also provided opportunity for her to document the way she develops her ideas.

Implications for Teaching and Learning

The implications of this research are discussed in the following headings.

Diagnosing students' pre-instructional knowledge

A review of the literature revealed that students hold pre-instructional knowledge before they are formally taught and teachers are frequently unaware of this. Moreover, students' pre-instructional knowledge persists despite formal instruction. The findings of this research suggest that POEs can be effective in diagnosing students' understanding of science concepts and the types of students' responses to contradictory observations. Therefore, POEs would be one of the useful diagnostic tools that can be employed in the classroom to probe students' pre-instructional

knowledge before planning learning activities to help students' progress in their learning.

Assessment of students' level of achievement

The findings of this research also revealed that POEs are effective in identifying students' level of achievement in terms of the Student Outcome Statements of the Department of Education of Western Australia. As demonstrated by the two case studies described in chapter 7, quality information about individual students' pre-instructional knowledge can be used for formative assessment of students. Taking into account students' pre-instructional knowledge, subsequent learning activities can be designed to help students progress in their learning. Additionally, POEs can be designed and used in a series of POEs to obtain information on student learning. The information can then be used to identify students' level of achievement against the Student Outcome Statements. In other words, POEs can also be used as a tool for summative assessment. However, some collaboration between students may have occurred and assessment may not be solely based on each individual's learning.

Teacher development

The findings of the research described in chapter 6 suggest that the effectiveness of POEs also was dependent on the teacher's skills in designing POEs and his skills in conducting effective interviews with students based on written POE responses of students. Therefore, pre-service teachers and existing teachers who intend to use POEs would need to undergo professional development to acquire skills in designing effective POEs and in conducting effective interviews with students. Moreover, teachers also would need to inform themselves about interpretive action research methodology in order to track students' progress in the course of instruction.

Students' portfolio

Findings in this research described in chapter 7 suggest that POEs can be effective in facilitating the teacher's observations of individual students' progress over time. Furthermore, POEs are effective in enabling students to demonstrate changes in their

achievement as well as providing opportunity for them to document how they develop their science concepts. This result implies that teachers could use POEs to help students to develop a portfolio to document their progress in the course of instruction and learning.

In short, findings in this research have implications for curriculum development and learning strategies, teacher development, and the promotion and assessment of students' understanding and level of achievement.

Limitations of this Research

Pedagogical skills of the teacher

To obtain credible and quality data, the teacher who used POEs needs to fulfil the requirements necessary for designing effective POEs. Also the teacher needs to be skilful in conducting effective interviews with students. Therefore, the results and findings in this study cannot be transferred to any teacher who intends but is not skilled in using POEs.

Making consistent judgement about students level of achievement

This research provided data and interpretation for making judgement about individual students' level of achievement against a common set of outcomes using the Student Outcome Statements of the Department of Education of Western Australia. The judgement process was conducted by the teacher-researcher with consistency over the time of individual student's progress or level of achievement. However, the results of the teacher's judgement would be more plausible with the collaboration of another teacher. In other words, there is a need to use a process where there is comparability of judgement between teachers.

Suggestions for Further Research

The findings of this research shows that while POEs are effective and useful tools for diagnosing students' knowledge and in identifying their level of achievement, the

teacher who uses POEs needs to be skilled in using this diagnostic tool. An area for further research may be to design a study to determine how extensively and how effectively POEs are used in science classes in schools. A question to be asked is: Are teachers who are using POEs using them effectively to diagnose students' learning? Another suggestion for further research would be to evaluate the effectiveness of POEs in assessing students' achievement within and across schools against a set of outcomes other than the Australian Student Outcome Statements. The results of such studies may suggest a wider scope on the usefulness of POEs in teaching, learning and assessment.

REFERENCES

- Abell, S.K. & Eichinger, D.C. (1998). Examining the epistemological and ontological underpinnings in science education: An introduction. *Journal of Research in Science Teaching*, 35, 2, 107-109.
- Aguis, J. (1993). Sound and musical instruments. *Investigating*, 9, 4, 21-22.
- Allen, N.J. & Crawley, F. E. (1998). Voices from the bridge: Worldview conflicts of Kickapoo students of science. *Journal of Research in Science Teaching*, 35, 2, 111-132.
- Anderton, J. D., Garnett, P. J., Liddelow, W. R., Lowe, R. K., & Manno, I., J. (1996). *Foundations of chemistry*. Melbourne, Vic.: Addison Wesley Longman.
- Australia Academy of Science (1994). *Primary Investigations Book 1-7*. Canberra, Australia.
- Australian Education Council (1994). *A statement on science for Australian schools*. Melbourne, Australia: Curriculum Corporation.
- Australian Education Council (1994). *Science- a curriculum profile for Australian schools*. Melbourne, Australia: Curriculum Corporation.
- Baird, J.R., & Mitchell, I. J. (1986). *Improving the quality of teaching and learning- An Australian case study*. Melbourne, Australia: Monash University.
- Bliss, J. (1995). Piaget and after: The case of learning science. *Studies in Science Education*, 25, 139-172.
- Bliss, J., & Ogborn, J. (1994). Force and motion from the beginning. *Learning and Instruction*, 4, 7-25.
- Brickhouse, N. W. (1991). Facing ethical dilemmas in interpretive research. In J. J. Gallagher (Ed.), *Interpretive research in science education* (pp. 43-59). NARST monograph, number 4, Kansas State University: National Association for Research in Science Teaching.
- Brickhouse, N. W. (1993). *Evolving conceptions of ethical practice in interpretive research*. Paper presented in an International Conference on Interpretive Research in Science Education. National Science council, R.O.C. National Taiwan Normal University, November 25-28.

- Brown, D.E., & Clement, J. (1992). Classroom teaching experiments in mechanics. In R. Duit, F. Goldberg, & H. Niedderer (Eds.), *Research in physics learning: Theoretical issues and empirical studies* (pp. 380-397). Kiel, Germany: IPN.
- Buxton, L. (1978). Four levels of understanding. *Mathematics in School*, 7, 4, 36.
- Byers, V. & Herscovics, N. (1997). Understanding school mathematics. *Mathematics Teaching*, 81, 24-27.
- Carr, M. (1996). Interviews about instances and interviews about events. In D.F. Treagust, R. Duit, & B.J. Fraser (Eds.), *Improving teaching and learning in science and mathematics* (pp. 44-53). New York: Teachers College Press.
- Chalmers, A.F. (1999). *What is this thing called science?* University of Queensland Press, St Lucia, Queensland, Australia.
- Champagne, A.B., Gunstone, R.F., & Klopfer, L.E. (1985). Instructional consequences of students' knowledge about physical phenomena. In L. H. T. A. L. West & Pines (Eds.), *Cognitive structure and conceptual change* (pp. 61-90). Orlando, FL: Academic Press.
- Champagne, A.B., Klopfer, L.E., & Anderson, J. H. (1980). Factors influencing the learning of classical mechanics. *American Journal of Physics*, 48, 1074-1079.
- Chi, M. T. H. (1992). Conceptual change within and across ontological categories: Examples from learning and discovery in science. In R. Giere (Ed.), *Cognitive Models of Science: Minnesota studies in the philosophy of science* (pp. 129-160). Minneapolis, MN: University of Minnesota Press.
- Chi, M. T. H., Slotta, J. D., & de Leeuw, N. (1994). From things to process: A theory of conceptual change for learning science concepts. *Learning and Instruction*, 4, 27-43.
- Chinn, C. A. & Brewer, W. F. (1993). The role of anomalous data in knowledge acquisition: A theoretical framework and implications for science education. *Review of Educational Research*, 63, 1, 1-49.
- Chinn, C.A. & Brewer, W.F. (1998). An empirical test of a taxonomy of responses to anomalous data in science. *Journal of Research in Science Teaching*, 35, 6, 623-654.
- Closset, J.L. (1984). *Using cognitive conflict to teach electricity. Aspects of Understanding electricity.* Proceedings of an international workshop: Kiel, Germany: IPN.

- Cohen, L. & Manion, L. (1989). *Research methods in education*. London and New York: Routledge.
- Costa, M. (1994). Air activities for grade 6. *Investigating*, 10, 2, 17-19.
- Curriculum Corporation (1999). *Science Australia Book 1-4*. Melbourne, Australia.
- Curriculum Council. (1998). *Curriculum framework for kindergarten to Year 12 in Western Australia*. Perth, WA: Curriculum Council, Western Australia.
- DeJong, E., Armitage, F., Brown, M., Butler, P., and Hayes, J. (1994). *Physics one*. Melbourne: Heinemann Educational Australia.
- Denzin, N. K. (1988). Triangulation. In J. P. Keeves (Ed.), *Educational research, methodology, and measurement: An international handbook* (pp. 511-513). Sydney: Pergamon Press.
- Denzin, N.K. & Lincoln, Y.S. (1998). *Strategies of qualitative inquiry*. Thousand Oaks, CA, USA: Sage Publications
- Driver, R. (1988). Theory into practice II: A constructivist approach to curriculum development. In P. Fensham (Ed.), *Development and dilemmas in science education* (pp. 133-149). London. The Falmer Press.
- Driver, R. (1989). Students' conceptions and the learning of science. *International Journal of Science Education*, 11, 481-490.
- Driver, R. (1995). Constructivist approaches to science teaching. In L. Steffe, & J. Gale, (Eds.) *Constructivism in education* (pp. 385-400). Hillsdale, NJ: Erlbaum.
- Driver, R. & Oldham, V. (1986). A constructivist approach to curriculum development in science. *Studies in Science Education*, 13, 105-122.
- Driver, R., Squires, A., Rushworth, P. & Wood-Robinson, V. (1994). *Making sense of secondary science: Research into children's ideas*. London: Routledge.
- Duit, R. (1991). Student's conceptual frameworks: Consequences for learning in science. In S. M. Glynn, R. H. Young & B. K. Britton (Eds.), *The psychology of learning science* (pp. 65-85). Hillsdale, NJ: Erlbaum .
- Duit, R. (1994). *Conceptual change approaches in science education*. Paper presented at the 'Symposium on conceptual change', Friedrich-Schiller-University of Jena, Germany, September 1-3.
- Duit, R. (1995). 'Constraints on knowledge acquisition and conceptual change-The case of physics'. Paper presented at the Symposium 'Constraints on Knowledge

- Construction and Conceptual Change: A look across content domains', sixth European Conference for Research on Learning and Instruction, Nijmegen, The Netherlands, August 26-31.
- Duit, R., Goldberg, F. & Niedderer, H. (Eds.) (1992). *Research in physics learning: Theoretical issues and empirical studies*. Kiel: IPN.
- Duit, R., & Treagust, D.F. (1998). Learning in science: From behaviourism towards social constructivism and beyond. In Fraser, B.J., & Tobin, K.G. (Eds.) *International handbook of science education* (pp. 3-25). Dordrecht, The Netherlands: Kluwer Academic Publishers.
- Duit, R. & Treagust, D. F. (2003). Conceptual change: A powerful framework for improving science teaching and learning. *International Journal of Science Education*, 25(6), 671-688.
- Duit, R., Treagust, D.F., & Mansfield, H. (1996). Investigating student understanding as a prerequisite to improving teaching and learning in science and mathematics. In D.F. Treagust, R. Duit, & B.J. Fraser (Eds.), *Improving teaching and learning in science and mathematics* (pp. 17-31) New York: Teachers College Press.
- Education Department of Western Australia (1994). *Science-Student Outcome Statements with pointers and work samples: Working Edition*. Perth, WA: Education Department of Education of Western Australia.
- Education Department of Western Australia (1998). *Science-Student Outcome Statements. Outcomes and Standard Framework*. Perth, WA: Education Department of Education of Western Australia.
- Education Department of Western Australia. (1996). *Science Report. Report of the Student Outcome Statements trial 1994-1995*. Perth, WA: Education Department of Education of Western Australia.
- Erickson, F. (1993). *What can we learn from interpretative research in science education?* Paper presented in an International Conference on Interpretive Research in Science Education. National Taiwan Normal University, November 25-28.
- Erickson, F. (1986). Qualitative methods in research on teaching. In M.C. Wittrock (Ed.), *Handbook of research on teaching* (pp. 119-161). (3rd edn.) New York: Macmillan.

- Finster, D.C. (1989). Developmental instruction. Part 1. Perry's model of intellectual development. *Journal of Chemical Education*, 66, 8, 659-661.
- Gilbert, J.K., & Watts, M. D. (1983). Concepts, misconceptions and alternative conceptions: Changing perspectives in science education. *Studies in Science Education*, 10, 61-98.
- Goldberg, F. and Bendall, S. (1996). Computer-video-based tasks for assessing understanding and facilitating learning in geometrical optics. In D.F. Treagust, R. Duit, & B.J. Fraser (Eds.), *Improving teaching and learning in science and mathematics* (pp. 17-31) New York: Teachers College Press.
- Gorsky, P., & Finegold, M. (1994). The role of anomaly and of cognitive dissonance in restructuring students' concepts of force. *Instructional Science*, 22, 75-90.
- Grant, P., Johnson, L., & Sanders, Y. (1991). *Better links: Teaching strategies in the science classroom*. Melbourne, Victoria, Australia: STAV Publishing.
- Guba, E.G., & Lincoln, Y.S. (1989). *Fourth generation evaluation*. Newbury Park, CA: Sage Publication.
- Gunstone, R.F. (1988). Learners in science education. In P. Fensham (Ed.). *Development and dilemmas in science education*. London: The Falmer Press.
- Gunstone, R.F. (1990). Children's science: A decade of developments in constructivist views of science teaching and learning. *The Australian Science Teachers Journal*, 36, 4, 9-19.
- Hashweh, M.Z. (1986). Toward an explanation of conceptual change. *European Journal of Science Education*, 8, 3, 229-249.
- Harrison, A.G. (1996). *Learning about atoms and molecules: Using an ontological perspective to enhance our understanding of conceptual change*. Paper presented at the annual meeting of the American Education Research Association, New York, April 8-12.
- Harrison, A.G., Grayson, D.J., & Treagust, D.F. (1999). Investigating a grade 11 student's evolving conceptions of heat and temperature. *Journal of Research in Science Teaching*, 36, 1, 55-87.
- Heller, M.H., & Finley, N. (1992). Variable uses of alternative conceptions: A case study in current electricity. *Journal of Research in Science Teaching*, 29, 3, 259-275.

- Hewson, P., & Hennessey, M.G. (1992). Making status explicit: A case study of conceptual change. In R. Duit, F. Goldberg, & H. Neiderer (Eds.) *Research in physics learning* (pp. 176-187). Proceedings of an international workshop held at the University of Bremen, Kiel, IPN.
- Hewson, P.W., & Hewson, M.G.A.B. (1984). The role of cognitive conflict in conceptual change and the design of science instruction. *Instructional Science*, 13, 1-13.
- Hewson, P., & Hewson, M. (1992). The status of students' conceptions. In R. Duit, F. Goldberg, & H. Neiderer (Eds.) *Research in physics learning* (pp. 59-73). Proceedings of an international workshop held at the University of Bremen, Kiel, IPN.
- Hewson, M., & Hewson, P. (2003). Effect of instruction using students' prior knowledge and conceptual change strategies on science learning, *Journal of Research in Science Teaching*, 40, S86-S98.
- Hewson, P.W. & Thorley, N. R. (1989). The conditions of conceptual change in the classroom. *International Journal of Science Education*, 11, 541-553.
- Jung, W. (1987). Understanding students' understandings: The case of elementary optics. In J.D. Novak(Ed.), *Proceedings of the Second International Seminar on Misconceptions and Educational Strategies in Science and Mathematics* (vol 3, pp 268-277). Ithaca, NY: Cornell University.
- Kearney, M. & Treagust, D.F. (1999). *Using multimedia supported POE tasks to probe student understanding*. Paper presented at the annual meeting of the Australian Science Education Research Association, Rotorua, New Zealand, July 8-11.
- Kearney, M. & Treagust, D. F. (2001). Constructivism as a referent in the design and development of a computer program using interactive digital video to enhance learning in physics. *Australian Journal of Educational Technology*, 17(1), 64-79.
- Kearney, M, Treagust, D.F., Yeo, S & Zadnik, G. (2001). Student and Teacher Perceptions of the Use of Multimedia Supported Predict-Observe-Explain Tasks to Probe Understanding. *Research in Science Education*, 31(4), 589-615.
- Kemmis, S., & McTaggart, R. (1988). *The action research planner*. Melbourne, Australia. Deakin University Press. Victoria.

- Kuhn, T. (1970). *The structure of scientific revolutions*. (2nd edition, Enlarged) Chicago,IL: University of Chicago Press.
- Liew, C.W. (1996). Probing students' science. In *SCOPE: Teachers' stories*. W.A. Cross-Sectorial Consortium, Perth, Western Australia: Department of Education.
- Liew, C.W. & Treagust, D.F. (1995). A Predict-Observe-Explain teaching sequence for learning about students' understanding of heat and expansion of liquids. *The Australian Science Teachers Journal*, 41, 1, 68-71.
- Lederman, N.G. (1992). Students' and teachers' conceptions of the nature of science: A review of the research. *Journal of Research in Science Teaching*, 29, 4, 331-359.
- Mathison, S. (1988). Why triangulate? *Educational Researcher*, March, 13-17.
- McNiff, J. (1988). *Action research: Principles and practice*. London: MacMillan Education Ltd.
- Merriam, S. B. (1988). *Case study research in education*. San Francisco: Jossey-Bass Inc.
- Miller, D. & Kandl, T. (1991). Knowing what, how, why. *The Australian Mathematics Teacher*, 47, 3, 4-8.
- Nickerson, R.S. (1985). Understanding understanding. *American Journal of Education*, 93, 2, 201-239.
- Nusirjan & Fensham, P. (1987). Descriptors and frameworks of solutions and reactions in solutions. *Research in Science Education*, 17, 139-148.
- Osborne, R., & Freyberg, P. (1985). *Learning in science: The implication of children's science*. Auckland: Heinemann.
- Osborne, R.J., & Wittrock, M.C. (1983). Learning science: A generative process. *Science Education*, 67, 489-508.
- Palmer, D. (1995). The POE in the primary school: An evaluation. *Research in Science Education*, 25(3), 323-332.
- Pintrich, P.R., Marx, R.W., & Boyle, R.A. (1993). Beyond cold conceptual change: The role of motivational beliefs and classroom contextual factors in the process of conceptual change. *Review of Education Research*, 63, 167-200.

- Posner, G.J., Strike, K.A., Hewson, P.W., & Gertzog, W.A. (1982). Accommodation of a scientific conception: Towards a theory of conceptual change. *Science Education*, 66, 211-227.
- Prieto, T., Blanco, A. & Rodriguez, A. (1989). The ideas of 11 to 14-year-old students about the nature of solutions. *International Journal of Science Education*, 11, 4, 451-463.
- Scott, P. H. (1991). Conceptual pathways in learning science: A case study of the development of one student's idea relating to the structure of matter. In Duit, R., Goldberg, F. & Niedderer, H. (Eds.), *Research in physics learning: Theoretical issues and empirical studies* (pp. 203-224) Kiel, Germany: IPN.
- Scott, P.H., Asoko, H.M. & Driver, R.H. (1991). Teaching for conceptual change: A review of strategies. In Duit, R., Goldberg, F. & Niedderer, H. (Eds.), *Research in physics learning: Theoretical issues and empirical studies* (pp. 310-329) Kiel, Germany: IPN.
- Sencar, S. & Eryilmaz, A. (2004). Factors mediating the effect of gender on ninth-grade Turkish students' misconceptions concerning electric circuits, *Journal of Research in Science Teaching*, 41, 6, 603-616.
- Shepardson, D.P. & Moje, E.B. (1999). The role of anomalous data in restructuring fourth graders' frameworks for understanding electric circuits. *International Journal of Science Education*, 21, 1, 77-94.
- Shipstone, D.M. (1984). A study of children's understanding of electricity in simple DC circuits. *European Journal of Science Education*, 6, 2, 185-198.
- Skemp, R.R. (1976). Relational understanding and instrumental understanding. *Mathematics Teaching*, 77, 20-26.
- Spector, B.S. (1984). Qualitative research: Data analysis framework generating grounded theory applicable to the crises in science education. *Journal of Research in Science Teaching*, 21, 439-467.
- Slotta, J.D., Chi, M.T.H., & Joram, E. (1995). Assessing students' misclassifications of physics concepts: An ontological basis for conceptual change. *Cognition and Instruction*, 13, 3, 373-400.
- Tamir, P. (1990). Justifying the selection of answers in multiple choice items. *International Journal of Science Education*, 10, 159-169.

- Tao, P., & Gunstone, R.F. (1997). *Conceptual change in science through collaborative learning at the computer*. Paper presented at the National Association for Research in Science Teaching annual meeting, Oak Brook, IL, USA, March 21-24.
- Tobin, K. (1989). Teachers as researchers: Expanding the knowledge base of teaching and learning. In M. L. Matyas, K. Tobin, & B. J. Fraser (Eds.), *Looking into windows: Qualitative research in science education*. Washington, D.C.: American Association for the Advancement of Science.
- Treagust, D.F. (1988). Development and use of diagnostic tests to evaluate students' misconceptions in science, *International Journal of Science Education*, 10, 159-169.
- Treagust, D.F. (1996). *Conceptual change: A multi-dimensional interpretive framework*. Paper presented at the annual meeting of the American Educational Research Association, New York City, USA, April 8-12.
- Treagust, D. F. & Chittleborough, G. (2001). Chemistry: a matter of understanding representations, *Subject-Specific Instructional Methods and Activities*, 8, 239-267.
- Treagust, D.F., Duit, R. & Fraser, B.J. (Eds.) (1996). *Improving teaching and learning in science and mathematics*. New York: Teachers College Press.
- Treagust, D.F., Venville, G., Harrison, A.G., & Tyson, L. (1997). *Diagnosing changes in conceptual status based on transcripts of students' interviews and classroom interactions*. Paper presented at the annual meeting of the Special Interest Group, Subject Matter Knowledge and Conceptual Change at the American Educational Research Association, Chicago, USA, March 24-28.
- Tripp, D. (1996). *SCOPE program booklet, Action Research: The first cycle*. Perth, WA: Education Department of Education of Western Australia.
- Tyson, L.M., Venville, G.J., Harrison, A.G., & Treagust, D.F. (1997). A multi-dimensional framework for interpreting conceptual change events in the classroom. *Science Education*, (81), 387-404.
- Tytler, R. (1993). Teaching science using toys and tricks. *Investigating*, 9, 17-19.

- Venville, G.J. (1996). *Learning about genetics: Using a multi-dimensional interpretative framework for understanding conceptual change*. Paper presented at the annual meeting of the American Education Research Association, New York, USA, April 8-12.
- White, R. & Gunstone, R. (1992). *Probing understanding*. London: The Falmer Press.
- Willis, S. & Kissane, B. (1995a). *Outcome-based education: A review of the literature*. Perth, WA: Education Department of Western Australia
- Willis, S. & Kissane, B. (1995b). *Systemic approaches to articulating and monitoring expected student outcomes*. Perth, WA: Education Department of Western Australia,
- Willis, S. (1997). Professional judgement and outcomes. In J. Gear, J. Johnston & B. Kissane (Eds.), *Using Student Outcome Statements in Mathematics: The NPDP Experience*. Claremont, Western Australia: The Mathematical Association of Western Australia (Inc.).

APPENDIX

STUDENT OUTCOME STATEMENTS

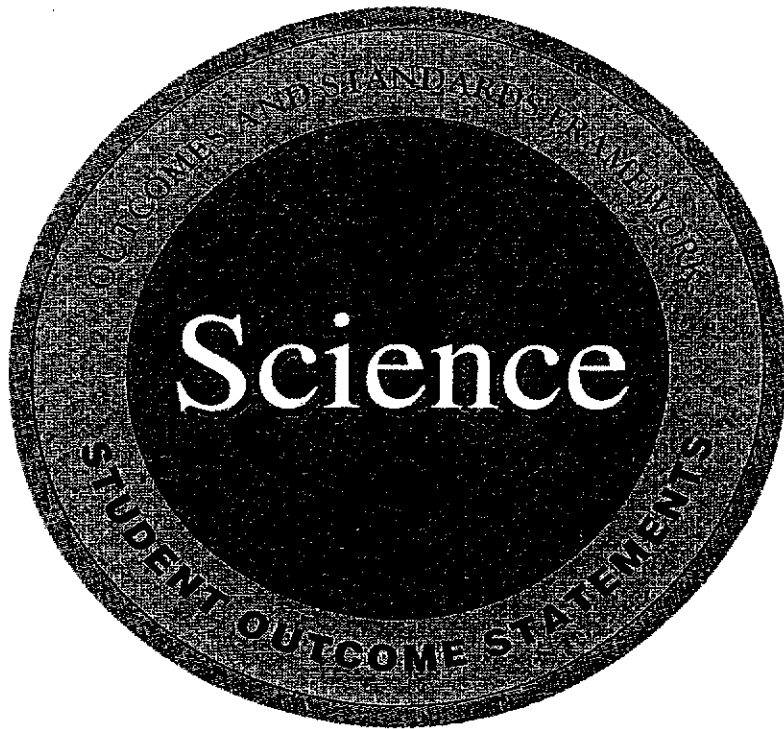

© Education Department of Western Australia 1998

Reproduction of this work in whole or part for educational purposes within an educational institution and on condition that it not be offered for sale, is permitted by the Education Department of Western Australia.

SCIS No: 942698

ISBN 0 7309 8672 1

<http://www.cddept.wa.edu.au/centoff/outcomes/>

FOUNDATION OUTCOME STATEMENTS



Planning

Students plan investigations to test ideas about the natural and technological world.

IS F.1

The student demonstrates an awareness of familiar objects and events.

This will be evident when students, for example:

- anticipate familiar routines, e.g. put school bags in correct place
- give sensory focus to a display or investigation, e.g. look, touch, smell, hear, taste
- identify objects, e.g. point to lunch box.



Conducting

Students conduct investigations to test ideas about the natural and technological world.

IS F.2

The student explores the environment using the senses.

This will be evident when students, for example:

- follow a one- or two-step instruction
- search for source of stimuli, such as turning their head to the direction of music
- explore objects using the senses, such as smelling and tasting ingredients during cooking.



Presenting Data

Students collect and present data from their investigations.

IS F.3

The student responds to an object or event.

This will be evident when students, for example:

- respond to a change in a familiar routine, such as showing excitement when celebrating a birthday in class
- respond to sensory stimulation, such as smiling when a cause-and-effect toy is activated
- communicate response to an experience, such as changing facial expressions after tasting various foods.



Evaluating

Students reflect on an investigation, evaluate the process and generate further ideas.

IS F.4

The student demonstrates choice making skills.

This will be evident when students, for example:

- request actions and activities to experience desired effect
- indicate likes/dislikes, such as choosing a preferred toy
- demonstrate that objects have the same function in different environments.



LEVEL

1

IS 1.1

The student focuses on problems and responds to teacher's suggestions and questions.

This will be evident when students, for example:

- tell about their own experiences of a phenomenon
- contribute to a list of what the class members know about a topic
- respond to teacher questions about 'What would we like to know?', 'How can we find out?'

↳

IS 1.2

The student carries out activities involving a small number of steps; and observes and describes.

This will be evident when students, for example:

- collect materials following teacher directions
- carry out an investigation involving a small number of steps
- tell what they did and observed.

↳

IS 1.3

The student shares observations.

This will be evident when students, for example:

- tell what they observed
- act out what they did or what happened
- draw what happened.

↳

IS 1.4

No outcome specified at this level.

- *Not applicable.*

LEVEL

2

IS 2.1

The student identifies, given a focus question in a familiar context, some of the variables to be considered.

This will be evident when students, for example:

- contribute to brainstorming of variables that could be considered
- recognise which variable is to be the focus of the investigation
- say how information will be gathered about the variable.

↳

IS 2.2

The student observes, classifies, describes and makes simple non-standard measurements and limited records of data; and uses independent variables that are usually discrete.

This will be evident when students, for example:

- use simple, non-standard measurements
- use pictures, words or numbers to record observations
- place objects into groups.

↳

IS 2.3

The student makes comparisons between objects or events observed.

This will be evident when students, for example:

- compare events, such as 'The marble rolled further on the steeper slope'
- compare places, such as 'There were more animals in the bush than in the park'.

↳

IS 2.4

The student comments on what happened and can say whether what happened was expected.

This will be evident when students, for example:

- comment on what happened
- can say whether what happened was expected
- can say whether the outcome was different from the prediction.

↳

Planning

Students plan investigations to test ideas about the natural and technological world.

IS 3.1

The student plans for investigations, showing some awareness of the need for fair testing; and makes simple predictions (not guesses) based on personal experience.

This will be evident when students, for example:

- identify something that will be kept the same
- plan to do things in the same way
- from past experiences, say what they think will happen.

**Conducting**

Students collect data, identify patterns, make predictions, and evaluate the results of their investigations.

IS 3.2

The student uses simple equipment in a consistent manner; and records data in simple tables, diagrams or observations.

This will be evident when students, for example:

- use the equipment in the same way for different trials or treatments
- make simple measurements using standard units
- choose forms of data presentation that are appropriate for the types of data, such as lists, tables, diagrams, audio or videotape
- take some responsibility to ensure safety.

**Processing Data**

Students organise data into tables and diagrams, and identify patterns in the data.

IS 3.3

The student displays numerical data as tables or bar graphs, and identifies patterns in data and summarises the data.

This will be evident when students, for example:

- organise numerical data into tables and identify patterns (groups, trends or relationships) in the data
- draw bar graphs to show patterns (groups, trends or relationships) in the data
- summarise in conclusions but do not explain the patterns (groups, trends or relationships) in the data
- can relate an effect to a cause.

**Evaluating**

Students reflect on their investigations, evaluate the process and make further ideas.

IS 3.4

The student identifies difficulties experienced in doing the investigation.

This will be evident when students, for example:

- say that it was difficult to make exact measurements
- identify external factors that influenced the results.



LEVEL

4

IS 4.1

The student identifies the variables to be changed, the variable to be measured and at least one variable to be controlled or, in a descriptive study, plans for the types of observations that need to be made.

This will be evident when students, for example:

- plan specifying the two main variables (independent and dependent)
- plan to keep at least one variable the same
- say how they will collect data for the independent and dependent variables
- select an appropriate data collection procedure.

↳

IS 4.2

The student takes care with data collection so that data are accurate; uses repeated trials or replicates; and uses independent variables that are usually continuous.

This will be evident when students, for example:

- use equipment appropriately and consistently
- measure accurately to one scale division
- make more than one measurement for each treatment
- recognise the need for safety precautions, such as safety glasses.

↳

IS 4.3

The student calculates averages from repeated trials or replicates; plots data as line graphs where appropriate; and makes conclusions which summarise and explain patterns in the data.

This will be evident when students, for example:

- calculate averages from repeat trials or replicates
- sum data over intervals, such as daily rainfall over a month
- plot discrete data for independent variables as bar graphs and continuous data as line graphs
- summarise the data and attempt to explain the patterns and/or relationships between the variables.

↳

IS 4.4

The student makes general suggestions for improving the investigation.

This will be evident when students, for example:

- say that better equipment was needed to do the experiment properly
- say that measurements need to be more exact
- say that the testing needs to be repeated more times.

↳

LEVEL

5

IS 5.1

The student analyses problems, formulates a question or hypothesis for testing, and plans an experiment in which several variables are controlled.

This will be evident when students, for example:

- write a question or hypothesis to focus the planning of their investigation
- list variables possibly important in the investigation and plan to control several of these
- plan data collection procedures and techniques to be used.

↳

IS 5.2

The student uses equipment that is appropriate for the task; and uses preliminary trials of the investigative procedure to improve the procedure or measurement techniques.

This will be evident when students, for example:

- select an appropriately-sized measuring cylinder or spring balance that will enhance accuracy
- use preliminary trials to improve the procedure or measurement technique
- take enough measurements to gauge reliability.

↳

IS 5.3

The student makes conclusions which are consistent with the data and explains patterns in the data in terms of scientific knowledge.

This will be evident when students, for example:

- explain the patterns in the data or relationships between the variables in terms of scientific knowledge
- write conclusions that reflect closely the magnitudes and patterns in the data.

↳

IS 5.4

The student suggests specific changes that would improve the techniques used or the design of the investigation.

This will be evident when students, for example:

- say how the measurement procedure can be made more accurate
- identify a variable that was not kept the same across treatments and say how it should have been controlled
- say how the measurement procedure could have been applied more consistently.

↳

Planning

Students plan investigations to test ideas about the biological and physical world.

IS 6.1

The student analyses a problem, formulates a question or hypothesis for testing, uses scientific knowledge to identify main variables to be considered and make predictions, and plans for accurate measurement.

This will be evident when students, for example:

- use scientific knowledge to identify the key variables that influence the phenomenon
- use scientific knowledge in developing predictions
- use scientific knowledge to plan chemical tests for analytical work
- consider how to enhance the accuracy of measurements.

↳

Conducting

Students will plan, record a variety of information relevant to their investigations.

IS 6.2

The student decides what is needed and requests equipment for the investigation; and selects equipment and instruments that enhance the safety and accuracy of measurements and observations.

This will be evident when students, for example:

- choose equipment that enhances safety and accuracy of measurement
- recognise difficulties in making accurate measurements
- use operational definitions to enhance consistency of measurement decisions
- avoid parallax error.

↳

Processing Data

Students will plan and analyse information to find patterns and draw conclusions to extend their understanding.

IS 6.3

The student selects the type of graph and scales that display data effectively; and draws conclusions which are consistent with the data, explained in terms of scientific knowledge and related to the question, hypothesis or prediction.

This will be evident when students, for example:

- make appropriate decisions about the type of graph to use which is best for the purpose and type of data
- select appropriate origin, range and intervals for graph scales
- evaluate the question or hypothesis in terms of the data.

↳

Evaluating

Students reflect on an investigation, evaluate the process and generate further ideas.

IS 6.4

The student recognises inconsistencies in the data, identifies the main sources of error and suggests improvements that would reduce the source of error.

This will be evident when students, for example:

- recognise that differences in observations or measurements for repeat trials or replicates are too large and represent error
- identify the main source of error
- suggest changes to the design or technique that would minimise or eliminate that error.

↳

LEVEL

7

IS 7.1

The student identifies own real-world problem for investigation, uses reference material in developing an understanding of the problem, and plans one or more experiments in an ongoing investigation.

This will be evident when students, for example:

- identify a real-world problem worthy of scientific investigation
- use reference material and own scientific knowledge to develop an understanding of the problem
- formulate several questions or hypotheses for testing
- plan a sequence of experiments or a long-term investigation
- plan for accurate data collection and structured data.

↳

IS 7.2

The student makes systematic observations and measurements with precision, using standardised techniques and recognises when to repeat measurements.

This will be evident when students, for example:

- develop or refine measurement and/or observational techniques
- maintain consistency in measurement procedure to produce precise measurements
- monitor consistency of data as it is collected
- make objective decisions for discarding discrepant results and repeating measurements.

↳

IS 7.3

The student draws conclusions which are consistent with the data, explains them in terms of scientific knowledge and does not over-generalise; and questions whether the data are sufficient to support the conclusions drawn.

This will be evident when students, for example:

- write conclusions that do not go beyond the data, that is, are not over-generalised
- write conclusions that indicate an appropriate level of confidence in the data.

↳

IS 7.4

The student recognises sources of measurement error, limitations in sampling and inadequacies in control of variables, and explains how these deficiencies can be remedied.

This will be evident when students, for example:

- write about limitations in measurement, control of variables and sampling in the conclusions section of their laboratory reports
- review limitations and main sources of error when presenting a seminar on an investigation.

↳

LEVEL

8

IS 8.1

The student shows, in planning and working independently, an *a priori* recognition for the need for control of variables, accuracy of measurement, adequate sample size and repeated trials or replications.

This will be evident when students, for example:

- understand that the need for thorough control of variables influences the search for important variables and ways of controlling them in the design and techniques used.
- plan for measurement, considering the range and intervals of measurement, choice of apparatus and techniques, and refinement of the measurement technique.
- plan for data collection showing an awareness of the need for samples to be representative and sufficiently large, and for repeat trials or replication to be used where appropriate.
- plans for triangulation of data.

↳

IS 8.2

The student makes judgements about the accuracy required, range and intervals of measurement, and decides what observations are necessary and sufficient in qualitative work.

This will be evident when students, for example:

- choose appropriate range and intervals of measurement for the independent variable
- make different measurements to an appropriate level of accuracy
- record different measurements with an appropriate number of significant figures
- take enough readings to estimate the error of measurement
- collect data in ways that allow for triangulation and checks of consistency
- minimise impact of the investigation on animals, other people and the environment.

↳

IS 8.3

The student identifies anomalous observations and measurements and allows for these when drawing graphs and conclusions; and draws conclusions which show awareness of uncertainty in data and does not over-generalise, and includes a discussion of limitations, the methods of data collection and/or design.

This will be evident when students, for example:

- account for anomalous observations when graphing and/or interpreting data
- write conclusions that include a discussion of the limitations of the design and/or data collection methods.

↳

IS 8.4

The student evaluates the findings and the experimental design, reformulates the problem, and plans follow-up experiments in an ongoing investigation, and refinements to experimental techniques and design.

This will be evident when students, for example:

- evaluate the impact of the investigation on animals and the environment
- evaluate the findings in terms of the hypothesis, existing theory and the problem
- evaluate the design and procedure and identify changes that are needed for follow-up experiments.

↳