

# Geopolymer Concrete Columns under Combined Axial Load and Biaxial Bending

Muhammad M Rahman<sup>1</sup> and Prabir K Sarker<sup>2</sup>

<sup>1</sup>Postgraduate student, <sup>2</sup>Senior Lecturer

Department of Civil Engineering, School of Civil and Mechanical Engineering, Curtin University, Perth, Western Australia

**Synopsis:** Fly Ash based geopolymer concrete is an alternative concrete that uses fly ash instead of cement. It is important to study the performance of a new material in various applications for its use in construction of structures. This paper presents the behavior of geopolymer concrete columns under combined axial load and biaxial bending. Twelve reinforced geopolymer concrete slender columns were tested at different combination of biaxial load eccentricities. The compressive strength of concrete varied from 37 to 63 MPa and the reinforcement ratio was 1.47 % or 2.95 %. No change was observed in appearance of the columns and the cylinders after exposure to varying outside environment under direct sun and rain for more than one year. The failure behavior of the columns was similar to that of Ordinary Portland cement (OPC) concrete columns under biaxial loading. Strengths of the columns were calculated by using the well-known Bresler's load reciprocal formula and the current Australian Standard for OPC concrete. The mean ratio of the test strength to calculated strength of the columns is found to be 1.18. Thus, the Bresler's formula which is commonly used for the design of OPC concrete columns resulted in good correlation with test results of the geopolymer concrete columns.

**Keywords:** biaxial bending, columns, fly ash, geopolymer concrete.

## 1. Introduction

The demand of cement is increasing with the increase of population and the subsequent increase in the use of concrete as a construction material. OPC has been traditionally used as the binding agent in concrete. About one ton of carbon dioxide is emitted into the atmosphere in the production of one ton of cement. The present world is looking for alternative environmentally friendly binders to help reduce the increasing trend of global warming and climate change. Geopolymer concrete is an alternative of OPC concrete that uses a by-product material instead of cement. A base material such as fly ash that is rich in Silicon (Si) and Aluminum (Al) is reacted by an alkaline solution to produce the geopolymeric binder. The base material for geopolymerisation can be a single material or combination of various materials. Source materials such as low calcium fly ash (1-3), high calcium fly ash (4), metakaolin (5) and slag (6, 7), can be used to make geopolymer. Although different source materials are used to manufacture geopolymers, basically the reaction of the source materials with an alkaline solution results in a compact well cemented composite.

The coal-fired power stations generate fly ash as a by-product. Use of fly ash in geopolymer concrete will help reduce the carbon footprint of concrete. The results of recent studies (8-11) have shown the potential use of fly ash based geopolymer concrete as a construction material. It is important to study the performance of fly ash based geopolymer concrete in various structural applications for its use in the construction industry. The previous research on fly ash-based geopolymer concrete studied the short-term and the long-term properties. Various parameters that influence the compressive strength of geopolymer concrete were investigated (11, 12). It was shown that heat-cured geopolymer concrete possesses high compressive strength, undergoes very little drying shrinkage and moderately low creep, and shows good resistance to sulfate attack. Geopolymer concrete showed higher bond strength with reinforcing steel as compared to OPC concrete (9). Geopolymer concrete columns under uniaxial bending showed similar behavior to that of OPC concrete columns (13).

The corner columns in a building frame and the columns in a bridge are the most common examples of columns under biaxial bending. Axial load combined with biaxial bending is also common in internal columns of building frames. A substantial amount of research has been conducted on biaxial bending of OPC concrete columns (14, 15). However, no studies have been conducted on the biaxial bending of geopolymer concrete columns. This paper presents the experimental and analytical results of

twelve geopolymer concrete columns tested under combined axial load and biaxial bending. Various analytical methods are available in the literature related to the behaviour of OPC concrete columns under biaxial bending (15 - 18). The well known Bresler's reciprocal load formula (19) is used in this study to analyse the test columns. The equation is relatively simple to use and recommended in the design codes and standards.

## 2. Experimental Works

### 2.1 Materials

In this study, low-calcium fly ash was used as the base material. The alkalis were sodium hydroxide and sodium silicate solutions. Sodium hydroxide pellets were dissolved in water to make 14M and 16M solutions. The sodium silicate solution had a chemical composition of 14.7% Na<sub>2</sub>O, 29.4% SiO<sub>2</sub>, and 55.9% water by mass. A commercially available naphthalene sulphonated super plasticizer and normal tap water were added to improve the workability of fresh geopolymer concrete. Both the alkaline solutions were mixed together before adding to the fly ash and aggregates. Coarse aggregates of 10 mm and 7 mm maximum size and fine sand were used. The mixture proportions of geopolymer concrete used for the specimens are given in Table 1. Mixture 1 was used for the columns 1 to 6 and mixture 2 was used for the columns 7 to 12. The longitudinal reinforcement consisted of N12 deformed bars and the lateral reinforcement was 6 mm diameter wires. The yield strength of the 12 mm bars was 530 MPa.

**Table 1. Mixture proportions of geopolymer concrete (kg / m<sup>3</sup>)**

Ingredients	Mixture 1 (Columns 1 – 6)	Mixture 2 Columns (7 – 12)
Fly Ash	406	404
10mm aggregate	551	555
7mm aggregate	643	640
Sand	643	640
Sodium hydroxide	41 (14M)	41 (16M)
Sodium silicate	102	102
Water	26.8	20
Super plasticiser	6	6

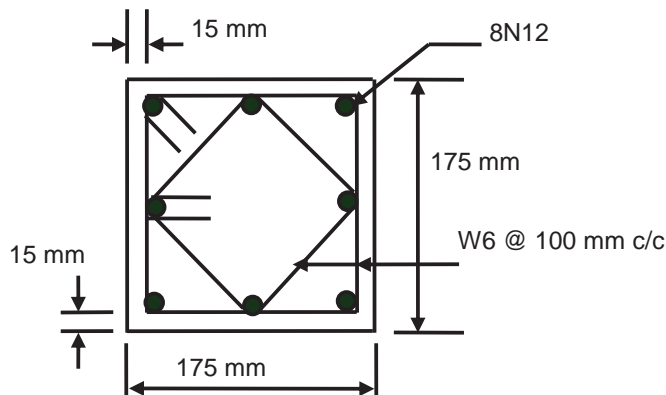

**Figure 1. Column cross-section (reinforcement ratio = 2.95 %).**

### 2.1 Test Columns

Twelve reinforced geopolymer concrete columns of 175 mm x 175 mm cross-section and 1500 mm in length were cast and cured by heat in the laboratory. The reinforcement ratio was either 1.47% or

2.95%. The longitudinal reinforcement of columns 1-3 and 7-9 consisted of 4 N12 bars and that of the other columns consisted of 8 N12 bars. The clear cover to the reinforcement was 15 mm. The cross-section of a column containing 8 N12 bars (2.95% reinforcement ratio) is shown in Figure 1. The concrete for each column was mixed separately in a pan type concrete mixer, placed into the mould containing the reinforcement cage and vibrated using an electrically operated concrete vibrator. The slump of fresh concrete varied between 190 and 250 mm. Companion 100 mm x 200 mm cylinder specimens were cast to determine the compressive strength of the concrete for each column. The columns and the cylinders were then put into the steam curing room and cured for 24 hours at 60 °C. All the specimens were demoulded after steam curing and left open in the outside environment until the test. The specimens were exposed to normal variations of the winter and summer weather conditions during this period. The mean compressive strength of concrete obtained from 5 cylinders at the test age of each column is given in Table 2.

## 2.2 Test Procedure

The columns were tested for different combination of biaxial load eccentricities by using a 2500 kN capacity universal testing machine. The test age of the columns varied depending on the availability of the test facilities. The load eccentricities at the top and bottom ends of the column were same in a direction. The age of each column during test and the load eccentricities are given in Table 2. Two sets of specially built end assemblages were attached to the top and bottom platens of the machine to apply the load to the column at biaxial eccentricities. These end assemblages were successfully used for previous testing of columns for uniaxial and biaxial bending (17, 20). The base plates are bolted rigidly to the top and bottom platens of the machine and attached to two sets of male and female knife-edges to transfer the eccentric load in X and Y directions. The knife-edge arrangements simulated hinge support conditions at both ends. With this arrangement, any load eccentricity of 0 to 70 mm at 5 mm interval could be obtained in both X and Y directions. A steel end cap was attached to the end plate to hold the column in position and maintain the eccentricities at the column's end throughout the test.

Before placing the column in the machine, the end assemblages were adjusted to the desired load eccentricities. The lines through the axes of the knife-edges represented the load eccentricities in X and Y directions. The base plates were first attached to the top and bottom platens of the test machine. The adaptor plate, with the set of knife-edges, was attached to base plate. The specimen was then placed into the bottom end cap and the machine platens were moved upward until the top of the column was into the top end cap. To secure the column axes parallel to the axes of the knife-edges, a small preload was applied to the specimen. The column was then gradually loaded until failure. A column in the test set up is shown in Figure 2. The load and mid-height deflection data were electronically recorded using a Nicolet data logging system.

**Table 2. Test variables of the columns**

Column	Reinforcement	Age at test (days)	Mean cylinder compressive strength $f_{cm}$ (MPa)	Eccentricity, $e_x$ (mm)	Eccentricity, $e_y$ (mm)
1	4N12	94	37	15	25
2	4N12	403	45	15	50
3	4N12	432	47	30	70
4	8N12	446	59	35	35
5	8N12	453	53	50	40
6	8N12	404	58	70	50
7	4N12	87	50	15	25
8	4N12	367	52	15	50
9	4N12	411	48	30	70
10	8N12	418	63	35	35
11	8N12	446	62	50	40
12	8N12	397	61	70	50

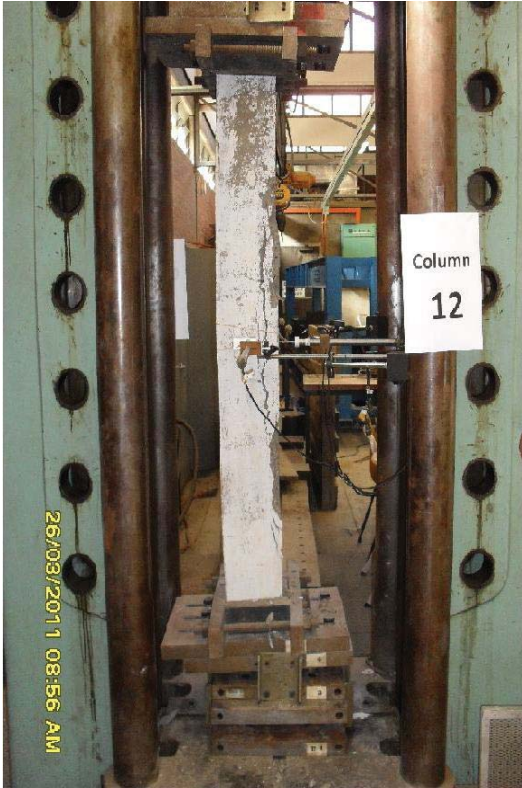

Figure 2. A column in the test set up.



(a) Cracks on tension sides



(b) Crushing on compression sides

Figure 3. Failure of typical test column.

### 3. Test Results

The columns and the cylinders were stored in open environment under direct exposure to sun and rain up to more than one year after steam curing. The specimens did not show any change in the appearance due to variation of the weather condition throughout the year. With the increase of loading, cracks initiated at mid height of the columns on the tension faces. As the load increased further, the existing cracks propagated and new cracks initiated in the tension faces. The cracks near the mid-height opened widely before the failure. The location of the failure zone varied to an extreme of 300 mm below or above mid-height. Failure occurred by spalling of the cover of reinforcement and subsequent crushing of the concrete in the compression faces around the mid-height of the columns. A sudden and explosive failure with a short post-peak behavior was observed in the columns with smaller load eccentricity and higher concrete strength. Typical cracks on the tension faces and crushing of concrete on the compression faces of a column are shown in Figure 3. The load versus the mid-height deflection graphs of test columns 1 to 6 are presented in Figure 4. The other columns showed similar load-deflection behaviors. As expected, generally the mid-height deflection increased with the increase of load eccentricity. Generally, the load-deflection and the failure behavior of geopolymer concrete columns under biaxial bending were similar to those usually exhibited by OPC concrete columns. The maximum load during the test and the corresponding mid-height deflections in X and Y directions of the columns are given in Table 3.

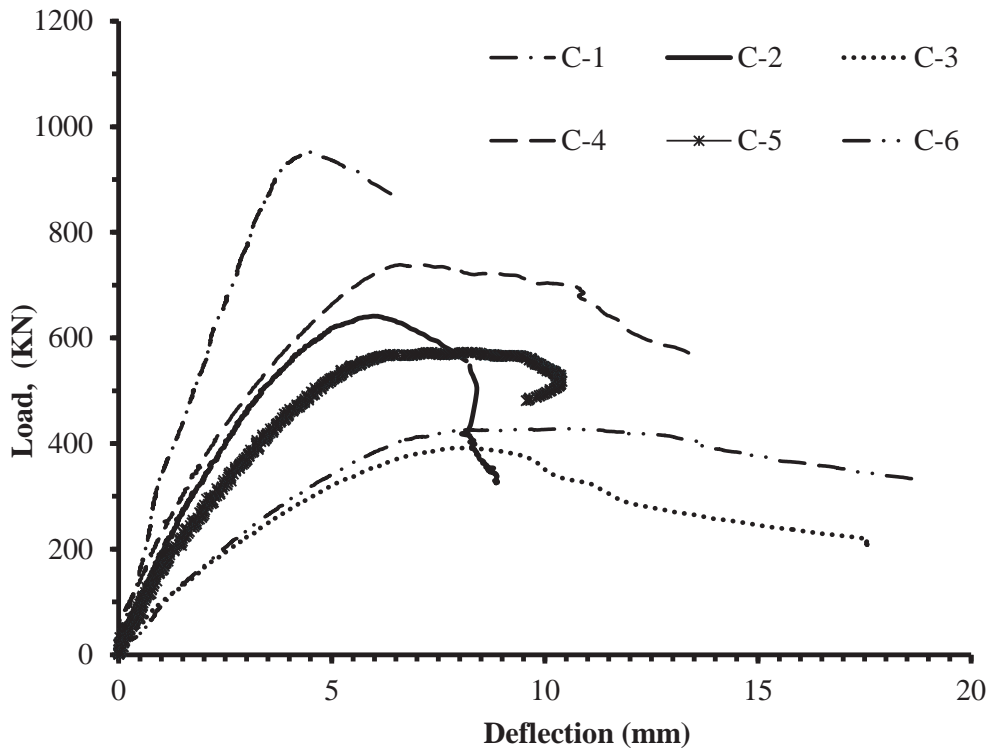

Figure 4. Load vs. mid-height deflection.

### 4. Calculation of the Failure Load

The failure loads of the test columns were calculated by using the well-known Bresler's reciprocal load formula (Equation 1) (19). The equation is simple and easy to use.

$$\frac{1}{P} = \frac{1}{P_x} + \frac{1}{P_y} - \frac{1}{P_0} \tag{1}$$

where,  $P$  = strength of the column in biaxial bending,  $P_x$  = strength at uniaxial load eccentricity  $e_y$ ,  $P_y$  = strength at uniaxial load eccentricity  $e_x$ , and  $P_0$  = strength under axial compression with no load eccentricity.

**Table 3. Test and analytical results**

Column	Mid height deflection $\Delta_x$ mm	Mid height deflection $\Delta_y$ mm	Test failure load $P_{test}$ , kN	Calculated failure load, $P_{calc}$ kN	$P_{test} / P_{calc}$
1	3.44	4.40	953	711	1.34
2	4.80	5.99	641	568	1.13
3	6.06	8.20	392	401	0.98
4	4.51	7.06	739	679	1.09
5	8.17	7.16	572	494	1.16
6	10.49	9.48	428	368	1.16
7	3.25	4.63	1377	900	1.53
8	3.64	7.27	786	625	1.26
9	5.19	8.96	445	408	1.09
10	4.52	7.37	776	699	1.11
11	8.49	6.06	646	614	1.05
12	8.70	7.35	452	373	1.21
Mean					1.18
Standard Deviation					0.15

The calculation needs the column's axial load capacities in pure compression, with bending about X axis only and with bending about Y axis only. The capacity of the column for pure axial load is calculated by using Equation 2.

$$P_0 = 0.85 f_{cm} A_g - A_s + f_y A_s \quad (2)$$

where,  $f_{cm}$  = mean cylinder compressive strength,  $A_g$  = gross cross sectional area,  $A_s$  = area of reinforcing steel and  $f_y$  = yield strength of steel.

The axial load capacities of the column for bending about X and Y axes only were performed by using an iterative procedure. A spreadsheet program was developed for the iterative calculations. The moment capacities of the cross-section and bending moments due to load were calculated for the assumed values of axial loads. The rectangular stress block parameters from the Australian Standard AS 3600 (21) were used in calculation of the moment capacity of the cross-section. The maximum bending moment of the column was calculated by taking into account the slenderness ratio and mid-height deflection. The mid-height deflections in X and Y directions were calculated by using Equations 3 and 4 (22).

$$\Delta = \Delta_b \frac{P_0 - P_u}{P_0 - P_b} \quad \text{where } P_u > P_b \quad (3)$$

$$\Delta_b = 0.003 + e \frac{L_e^2}{\pi^2 d_0} \quad (4)$$

where,  $\Delta$  = mid-height deflection,  $\Delta_b$  = mid-height deflection at balanced failure,  $P_u$  = ultimate load which is calculated in every iteration by dividing the section's moment capacity by the total load eccentricity including the column's mid-height deflection,  $P_b$  = load at balanced failure which is calculated for the simultaneous crushing of the concrete and yielding of the tensile steel,  $e$  = load eccentricity at column's end,  $L_e$  = effective length of column and  $d_0$  = effective depth of the cross-section.

The value of the axial load for which the mid-height bending moment in the column reached the moment capacity of the cross-section was taken as the ultimate load capacity for uniaxial bending.

The axial load capacities of the column for pure compression and uniaxial bending about X and Y axes were used in Equation 1 to determine the capacity of the column in biaxial bending. The calculated value of the failure load for each column is given in Table 3. As can be expected, some scatter is observed in the ratio of the test to calculated strengths of the columns. The mean ratio of the test to calculated failure loads of the columns is found to be 1.18 with a standard deviation of 0.15.

The ratio is found to be higher for the columns with relatively small load eccentricities (columns 1 and 7) than the columns with larger load eccentricities. Thus, method of calculation is relatively more conservative for the columns with small load eccentricities. Generally it is shown that the analytical method can be conservatively used for prediction of the strength of geopolymer concrete columns. Calculations using the characteristic strength instead of mean strength of concrete and the use of strength reduction factors would have resulted in more conservative predictions of the failure loads.

## 5. Conclusions

Low-calcium fly ash was used as the source material to make geopolymer concrete. Twelve slender reinforced geopolymer concrete columns were made and tested for combined axial compression and biaxial bending. From visual inspection, no change in appearance was observed in the columns and cylinders after direct exposure to sun and rain in varying weather conditions for more than one year. This showed the soundness of geopolymer concrete as a structural material in varying weather conditions. The general load-deflection and failure behaviors of the columns were similar to those usually exhibited by OPC concrete columns with biaxial bending. As expected, axial load capacity increased with the increase of concrete's compressive strength and reinforcement ratio, and decreased with the increase of load eccentricity. The load capacities of the columns were calculated by using the Bresler's load reciprocal formula, together with the considerations commonly used for slender concrete columns. The ratio of the test to calculated axial load capacities of the twelve test columns is found to be 1.18 with a standard deviation of 0.15. This shows the suitability of using the analytical method to geopolymer concrete columns subjected to combined axial load and biaxial bending.

## 6. References

1. Hardjito, D., Wallah, S. E., Sumajouw, D. M. J. and Rangan, B. V., "Fly Ash-Based Geopolymer Concrete," Australian Journal of structural Engineering, 6, 2005, pp. 77 – 86.
2. Hardjito, D., Wallah, S. E., Sumajouw, D. M. J. and Rangan, B. V., "On the Development of Fly Ash-Based Geopolymer Concrete", ACI Materials Journal, 101(6), 2004, pp. 467-472.
3. Fernandez- Jimenez, A., Palomo, A., "Engineering properties of alkali-activated fly ash concrete", ACI Materials Journal, 103, 2006, pp.106-112.
4. Chindaprasirt, P., Chareerat, T. and Sirivivatnanon, V., "Workability and strength of coarse high calcium fly ash geopolymer", Cement and Concrete Composites, 29, 2007, pp. 224-229.
5. Davidovits, J., "High-Alkali Cements for 21st Century Concretes", Concrete Technology Past, Present and Future, ACI Special Publication, SP 144, 1994, pp. 383-398.
6. Bakharev, T., Sanjayan, J. and Cheng, Y., "Alkali activation of Australian slag cements" Cement and Concrete Research, 29, 1999, pp. 113-120.
7. Fernandez-Jimenez, A. Palomo, J. G. and Puertas, F., "Alkali activated slag mortars: mechanical strength behavior", Cement and concrete Research, 29, 1999, pp. 1313-1321.
8. Rangan, B. V., "Studies on Low-calcium Fly Ash-based Geopolymer Concrete," Indian Concrete Journal, October – December, 2006, pp. 9-17.
9. Sarker, P. K., "Bond strength of Reinforcing Steel Embedded in Geopolymer Concrete", Materials and Structures, 44, 2011, pp. 1021 – 1030.
10. Sarker, P. K., "Analysis of Geopolymer Concrete Columns", Materials and Structures, 42, 2009, pp. pp. 715 – 724.
11. Fernandez-Jimenez, A. M., Palomo, A., and Lopez-Hombrados, C., "Engineering Properties of Alkali-Activated Fly Ash Concrete," ACI Materials Journal, Vol. 103, 2006 pp. 106–112.
12. Fernandez- Jimenez, A. and Palomo, A., "Composition and microstructure of alkali activated fly ash binder: effect of the activator", Cement & Concrete Research, 35, 2005, pp. 1984-1992.
13. Sumajouw, D. M. J., Hardjito, D., Wallah, S. E., and Rangan, B. V., "Fly Ash-Based Geopolymer Concrete: Study of Slender Columns", Journal of Materials Science, 42 (9), 2007, pp. 3124-3130.

14. Jin-Keun, K. and Sang-soon, L., "The behavior of reinforced concrete columns subjected to axial force and biaxial bending", Engineering Structures, 22 (11), 2000, pp. 1518-1528.
15. Cedolin, L., Cusatis, G., Eccheli, S. and Roveda, M., "Capacity of Rectangular Cross Sections under Biaxially eccentric Loads", ACI Structural Journal, 105 (2), 2008, pp. 215-224.
16. Ramamurthy L. N., "Investigation of the ultimate strength of square and rectangular columns under biaxially eccentric loads", In: Proceedings: Reinforced concrete columns, 1966. pp. 263–98.
17. Sarker, P. K., Adolphus, S., Patterson, S. and Rangan, V. B., "High strength Concrete Columns under Biaxial Bending", ACI Special Publication, 200, 2001, pp. 217 - 234.
18. Wang, G. G, Hsu, C. T., "Complete biaxial load-deformation behavior of RC columns", Journal of Structural Engineering, 118(9), 1992, pp. 2590–609.
19. Bresler, B., "Design Criteria for Reinforced columns under Axial Load and Biaxial Bending", ACI Journal, 57 (5), 1960, pp. 481 – 490.
20. Kilpatrick, A. E., "the Behavior of High Strength Concrete Composite concrete Columns", PhD thesis, Curtin University, Perth, Western Australia, 1996, 317 pp.
21. Standards Australia, "Australian Standard, Concrete Structures, AS 3600, 2009.
22. Rangan, V. B., "High Performance High strength Concrete: Design Recommendations", Concrete International, 20 (11), 1998, pp. 63 – 68.