

# A Review of Condition Monitoring Techniques of the Wind Turbines Gearbox and Rotor

Abdulwahed A. Salem  
Curtin University/Electrical&Computer,Perth,Australia  
Email: [a.salem@curtin.edu.au](mailto:a.salem@curtin.edu.au)

Ahmed Abu-Siada and Syed Islam  
Curtin University/ Electrical&Computer,Perth,Australia  
Email: A.AbuSiada, S.Islam@curtin.edu.au

**Abstract - Gearbox and the blades are classified as the most critical and expensive components of the wind turbine. Moreover, these parts are prone to high risk failure when compared to the rest of the wind turbine components. Due to the global significant increase in wind turbines, a reliable and cost effective condition monitoring technique is essential to maintain the availability and to improve the reliability of wind turbines. This paper aims to present a comprehensive review of the latest condition monitoring techniques for turbine gearbox and blades which are considered as the crux of any wind energy conversion system.**

**Index terms – Wind turbine, Condition monitoring, Gearbox, Blades**

## I. INTRODUCTION

Due to the degradation and cost increase of conventional fossil fuel along with the global trend to decrease the greenhouse effect, clean energy production from renewable sources has been given a great concern during the last few decades. Among those, wind energy conversion system (WECS) has received a remarkable attraction and it is estimated to produce about 10% of the global electricity by the year 2020[2]. For instance, countries such as Denmark, Germany and Spain, wind turbines are taking a part of the countrywide power networks. The reliability of wind turbines has a great influence on the performance of the network [1]. Late models of wind turbine come in two configurations; horizontal –axis (HAWTs) and vertical –axis (VAWTs) referring to rotor operating principle. The principle operation of both configurations is to change the kinetic energy of the wind into mechanical power that drives an alternating current induction generator to produce electricity. There is a constant need for the reduction of operational and maintenance costs of wind energy conversion systems (WECSs) through the adoption of

reliable and cost effective condition monitoring techniques that allow for the early detection of any degeneration in the system components, facilitating a proper asset management decision, minimizing downtime, and maximizing productivity. The cost of a wind turbine in comparison to a diesel generator is extremely high. Furthermore, regular maintenance can be up to 2% of the total price of the turbine[2]. However, occasional malfunction of specific parts such as blades, gearbox, tower, and braking system can result in high expenses and in some situations, may lead to a catastrophic failure jeopardising the whole investment. Wind turbines are different from traditional rotating machines as they usually operate in remote locations, rotate at low and variable speed and work under constantly varying loads[3]. For these reasons reliable condition monitoring system for wind turbines is essential to avoid catastrophic failures and to minimise the requirement of costly corrective maintenance[2].

## II. WIND TURBINE GEARBOX

When grid fault followed by electromagnetic transient torque takes place, the gearbox will experience fatigue and massive stress that will affect the overall performance of the wind turbine[4]. Condition monitoring of the drivetrain is essential to explore incipient faults allowing effective maintenance and reliability improvement. Various gearbox failures have been investigated in the literature [5]. Hot spots within gearbox may be developed due to the degradation of lubrication oil. This leads to high bearing temperature and accelerates the aging of lubrication oil. Another problem facing the gearbox is that when a wind gust hits the rotor blades, blades movement can cause a temporary misalignment between the two shafts connected through the gearbox. This misalignment can produce damage on the bearing loads and reduce lifetime of the wind turbine [6]. Vibration measurement of the gearbox and bearings

returns data that enable the calculation of the wind turbine mechanical characteristic. Attaching sensors to the rotational components of the wind turbine can estimate the acceleration level of various rotational spots which aids in identifying any incipient mechanical failure[7]. Spectral analysis is a way to analyse the vibration data based on Fourier transform. By analysing these spectrums, the health condition of rotating components can be identified. According to Zhang et al [8], wavelet and Fourier transformation are the common methods that have been used to identify gearbox faults. Wang et al[9] utilized wavelet method for fault diagnosis of a gearbox under fluctuating loads. Cibulka et al [10] investigated the bearing faults in a single stage gearbox attached to an induction machine by monitoring the stator current. Yuan and Lilong [11], analysed the vibration signal obtained from a healthy and damaged gearbox using the variable amplitude Fourier series and compare the outcomes with the wavelet analysis method. In [12], harmonic Wavelet-Based Data filtering is used for enhanced time frequency features for multiple sensors signals in order to improve failure identification and quantification. Molins at al [4], illustrated that by controlling the terminal voltage of induction generator through the compensation of reactive current using static synchronous compensator will mitigate the electromagnetic torque stress on the generator rotor shaft.

Luo *et al* [13], illustrate that vibration-based condition monitoring is one of the most effective techniques that can detect gearbox failure of wind turbine especially in the high speed side rather than low speed side. This is attributed to the inherent sensitivity of the accelerometers to high frequency vibration. Luo *et al* concludes that the digital domain synchronous sampling technique will enhance the performance of wind turbine drivetrain fault detection. Zhang et al [8] used time domain and frequency domain analysis for vibration data of an impaired gearbox by connecting the low speed side to the rotor and the high speed side to the generator as shown in Fig. 1. As a result, success achieved in detecting the fault of the intermediate- and high-speed stages[8].

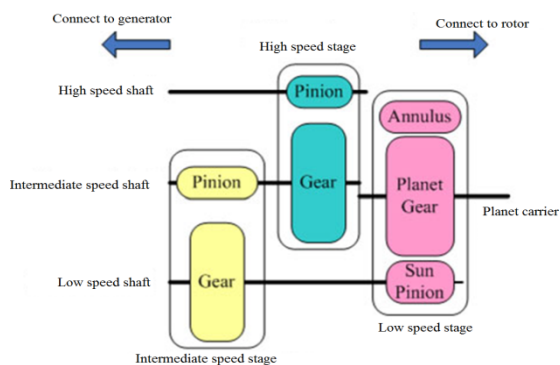

Fig.1. Gearbox Structure [8]

Figure (2) concludes the most effective condition monitoring technique for the gearbox [13]. Watson et al mentioned that spectral analysis of the output power

signal is an effective way to monitor the rotor asymmetry as well as the gearbox bearing faults[14]. Recently, Wavelets, high powerful tool, have been validated to detect the shaft misalignment and bearing troubles by analysing the output power signal of the variable speed wind turbine[15].

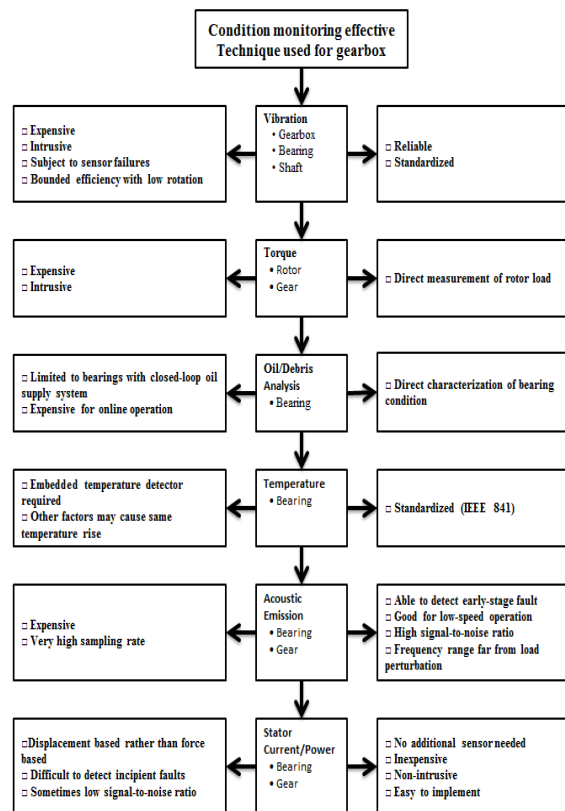

Fig. 2 Gearbox Condition monitoring Techniques.

### III. WIND TURBINE BLADES

Turbine blades are the most visible parts of the wind turbine. This component is playing a vital role to produce energy by transferring the wind kinetic energy to rotating mechanical energy[2]. Ciang *et al* illustrate that the likelihood section prone to mechanical faults is about 70% in chord length from the blade root as proven practically and by simulations [16].

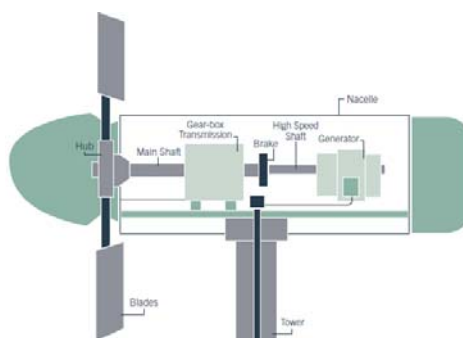

Figure (3): Diagram showing the inside of the nacelle(main components)[17].

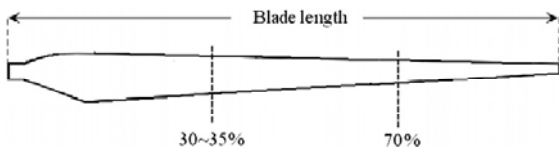

Figure (4) : The spanwise location of a blade that is likely to damage [11].

The wind power can be harvest by the blades in order to achieve a mechanical power is calculated as below.

$$P_M = \frac{1}{2} \rho A v_w^3 C_p$$

Where,  $\rho$  is the air density,  $A$  is the sweep,  $C_p$  is the power coefficient of the blade and  $v_w$  is the wind speed.

Modern wind turbines blades are generally made from fibre reinforced plastics mixed with other material such as plastic foam and wood. These materials have the advantage of low cost and high mechanical strength [10-11]. Wind turbine rotor should withstand  $10^8$  stress cycle in a 20 year of their estimated life taking into account creep and corrosion [18]. Rotor imbalance which produces large stress and instability operation affects the blades performance. Moreover, moisture attacks the surface may increase the growth of the existing cracks owing to cyclical freezing. Also, icing, surface roughness and any other fault occur while transportation has a negative effect on the blades performance [18].

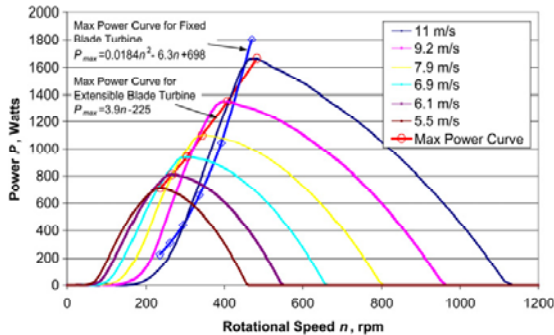

Fig. 5 Power curves for turbine with variable length blades [14].

Maki *et al* illustrated that taller tower will enhance the output power through increasing the wind captured by the swept area of the rotor as per the equation below.

$$V = V_{ref} \left( \frac{Hub_{Ht}}{H_{ref}} \right)^{0.34} \quad (1)$$

Where  $V$  is the wind speed at the hub,  $V_{ref}$  is the reference wind speed at the reference hub height and  $H_{ref}$  is the reference hub height. The power-law coefficient of 0.34 is suitable for neutrally stable air above human-inhabited areas [19]. Sharma *et al* [20], investigated the impact of variable blades length on the wind turbine performance. Results show that the variable length blades can capture almost twice that of the fixed length blades as can be shown in Fig 5. Besnard and Lina [21], report on different condition monitoring strategies for wind turbine

blades which include visual inspection, ultrasonic or thermography techniques, and online condition monitoring using fiber optic. Fig. 6 shows a comparison between different methods of the expected maintenance cost for different maintenance strategies for a practical case study in [15]. The figure reveals that online condition monitoring technique introduces the lowest maintenance cost for the case study mentioned.

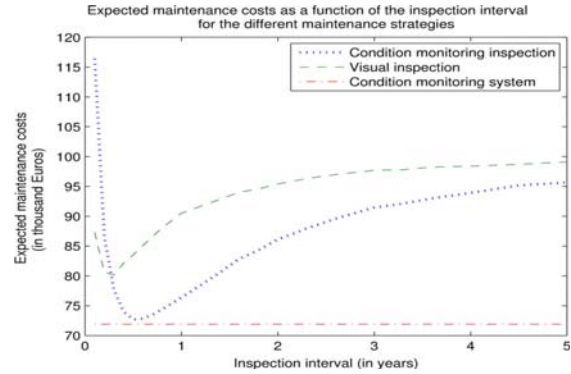

Fig.(6) Expected maintenance costs for the different maintenance strategies as a function of the inspection interval  $t_1$  for the case study (one blade) [15].

Schubel *et al* [22], compares different methods of monitoring large wind turbine blades, such as dielectric method, acoustic, ultrasonic and fibre optic method. Some difficulties are facing the implementation of these methods especially, the dielectric sensors method as sensors size will affect the resin mechanical performance [23-26].

#### IV. CONCLUSION

This paper aims to introduce a review of the current techniques used for detecting incipient mechanical faults within the gearbox and the rotor blades of the wind turbine. Vibration measurements are conducted by using either vibration sensors or spectral analysis algorithms. Wavelet is a very effective technique in analysing monitored parameters for fault identification and quantification. The offshore wind turbines with variable length blades are more efficient than those of fixed blade length. More investigation about the root failure causes, and improvement in sensor technologies and signal processing will lead to the enhancement of condition monitoring techniques, consequently availability, reliability, and less maintainability will be achieved to the wind energy conversion system as well as the grid.

#### REFERENCES

- [1] W. Yang, P. Tavner, and M. Wilkinson, "Condition monitoring and fault diagnosis of a wind turbine synchronous generator drive train," *Renewable Power Generation*, IET, vol. 3, pp. 1-11, 2009.
- [2] y. L. Bin Wu, Navid Zargari, Samir Kouro, *Power Conversion and Control of Wind Energy Systems* vol. 74. United States of America: John Wiley & Sons, Inc., Hoboken, New Jersey, 2011.

- [3] W. Yang, P. J. Tavner, C. J. Crabtree, Y. Feng, and Y. Qiu, "Wind turbine condition monitoring: technical and commercial challenges," *Wind Energy*, 2012.
- [4] M. Molinas, J. A. Suul, and T. Undeland, "Extending the life of gear box in wind generators by smoothing transient torque with STATCOM," *Industrial Electronics, IEEE Transactions on*, vol. 57, pp. 476-484, 2010.
- [5] C. Kar and A. Mohanty, "Monitoring gear vibrations through motor current signature analysis and wavelet transform," *Mechanical systems and signal processing*, vol. 20, pp. 158-187, 2006.
- [6] E. d. Vries. (2010) Wind turbine gearboxes and the effort to improve their reliability. *Wind Power*.
- [7] Z. Hameed, Y. Hong, Y. Cho, S. Ahn, and C. Song, "Condition monitoring and fault detection of wind turbines and related algorithms: A review," *Renewable and Sustainable Energy Reviews*, vol. 13, pp. 1-39, 2009.
- [8] Z. Zhang, A. Verma, and A. Kusiak, "Fault Analysis and Condition Monitoring of the Wind Turbine Gearbox," *Energy Conversion, IEEE Transactions on*, vol. 27, pp. 526-535, 2012.
- [9] X. Wang, V. Makis, and M. Yang, "A wavelet approach to fault diagnosis of a gearbox under varying load conditions," *Journal of Sound and Vibration*, vol. 329, pp. 1570-1585, 2010.
- [10] J. Cibulka, M. K. Ebbesen, and K. G. Robbersmyr, "Bearing Fault Detection in Induction Motor-Gearbox Drivetrain," in *Journal of Physics: Conference Series*, 2012, p. 012140.
- [11] L. C. Xiaohong Yuan, "Variable amplitude Fourier series with its application in gearbox diagnosis—Part II: Experiment and application," *ScienceDirect*, vol. 19, pp. 1067-1081, 2005.
- [12] J. Tang and H. Luo, "Wind Turbine Gearbox Fault Detection Using Multiple Sensors With Features Level Data Fusion," *Journal of Engineering for Gas Turbines and Power*, vol. 134, pp. 042501-1, 2012.
- [13] B. Lu, Y. Li, X. Wu, and Z. Yang, "A review of recent advances in wind turbine condition monitoring and fault diagnosis," in *Power Electronics and Machines in Wind Applications*, 2009. PEMWA 2009. IEEE, 2009, pp. 1-7.
- [14] S. J. Watson, B. J. Xiang, W. Yang, P. J. Tavner, and C. J. Crabtree, "Condition monitoring of the power output of wind turbine generators using wavelets," *Energy Conversion, IEEE Transactions on*, vol. 25, pp. 715-721, 2010.
- [15] E. Wiggelinkhuizen, T. Verbruggen, H. Braam, L. Rademakers, J. Xiang, and S. Watson, "Assessment of condition monitoring techniques for offshore wind farms," *Journal of solar energy engineering*, vol. 130, pp. 030301.1-031020.12, 2008.
- [16] C. C. Ciang, J.-R. Lee, and H.-J. Bang, "Structural health monitoring for a wind turbine system: a review of damage detection methods," *Measurement Science and Technology*, vol. 19, p. 122001, 2008.
- [17] R. S. A. W. Alasdair Lawrence, "NSW Wind EnergyHandbook," in *SEDA*, ed: Solutions for the future SEDA, 2002.
- [18] R. Hyers, J. McGowan, K. Sullivan, J. Manwell, and B. Syrett, "Condition monitoring and prognosis of utility scale wind turbines," *Energy Materials: Materials Science and Engineering for Energy Systems*, vol. 1, pp. 187-203, 2006.
- [19] K. Maki, R. Sbragio, and N. Vlahopoulos, "System design of a wind turbine using a multi-level optimization approach," *Renewable Energy*, 2011.
- [20] R. Sharma and U. Madawala, "The concept of a smart wind turbine system," *Renewable Energy*, vol. 39, pp. 403-410, 2012.
- [21] F. Besnard and L. Bertling, "An approach for condition-based maintenance optimization applied to wind turbine blades," *Sustainable Energy, IEEE Transactions on*, vol. 1, pp. 77-83, 2010.
- [22] P. Schubel, R. Crossley, E. Boateng, and J. Hutchinson, "Review of structural health and cure monitoring techniques for large wind turbine blades," *Renewable Energy*, vol. 51, pp. 113-123, 2013.
- [23] A. McIlhagger, D. Brown, and B. Hill, "The development of a dielectric system for the on-line cure monitoring of the resin transfer moulding process," *Composites Part A: Applied Science and Manufacturing*, vol. 31, pp. 1373-1381, 2000.
- [24] V. Antonucci, M. Giordano, A. Cusano, J. Nasser, and L. Nicolais, "Real time monitoring of cure and gelification of a thermoset matrix," *Composites science and technology*, vol. 66, pp. 3273-3280, 2006.
- [25] R. Harrold and Z. Sanjana, "Acoustic waveguide monitoring of the cure and structural integrity of composite materials," *Polymer Engineering & Science*, vol. 26, pp. 367-372, 1986.
- [26] D. D. Shepard and K. R. Smith, "Ultrasonic cure monitoring of advanced composites," *Sensor Review*, vol. 19, pp. 187-194, 1999.

**Abdulwahed A. Salem** was born in Zawia, Libya. He received the B.Eng. degree in electrical & Electronic Engineering from Garyounis University in Benghazi, Libya, in 2000, and the MSc. degree in Electrical Engineering from Curtin University, Australia, in 2011. He is currently pursuing his PhD program within the Electrical and Computer Engineering Department at Curtin University. Prior joining Curtin, Mr Salem was working for protection settings department as protection Engineer in GECOL Company in Libya. Mr Salem has attended many international training courses in different countries in Europe about relays setting calculations and software practices

**A. Abu-Siada (SM'12)** received his B.Sc. and M.Sc. degrees from Ain Shams University, Egypt and the PhD degree from Curtin University of Technology, Australia, All in Electrical Engineering. Currently, he is a senior lecturer in the Department of Electrical and Computer Engineering at Curtin University. His research interests include power system stability, Condition monitoring, Power Electronics, Power Quality, Energy Technology and System Simulation. He is a regular reviewer for the IEEE Transaction on Power Electronics, IEEE Transaction on Dielectrics and Electrical Insulations, and the Qatar National Research Fund (QNRF).