

PMU based Wide Area Voltage Control of Smart Grid: A Real Time Implementation Approach

Ahmed S. Musleh, S. M. Muyeen, Ahmed Al-Durra, and Haris M. Khalid

Department of Electrical Engineering, The Petroleum Institute
Abu Dhabi, UAE

E-mail: amusleh@pi.ac.ae

Abstract — This paper demonstrates a wide area control scheme for voltage regulation in smart grids. The core objective of this work is to create a realistic wide area control (WAC) approach for controlling the voltage in a modern power system. The measurements are collected using phasor measurement units (PMUs) which are optimally placed into the grid via genetic algorithm (GA). The information from each PMU is then used as the feedback for the wide area controller. A flexible AC transmission system (FACTS) device is used as a reactive power compensation tool to demonstrate the use of WAC action to the local area controller. A real time implementation is carried out using Real Time Digital Simulator (RTDS). Furthermore, a Software-in-the-Loop (SIL) system is developed which connects the RTDS simulation to a MATLAB based program. This program receives the PMU measurements from the RTDS and calculates the WAC action which is sent back to the RTDS simulation. Various tests are conducted to demonstrate the usefulness of the wide area control scheme and its reliability. The results show an acceptable behavior of the designed wide area controller.

Index Terms-- FACTS, PMU, reactive power compensation, real time digital simulator, wide area monitoring and control.

I. INTRODUCTION

Reliability and security of power systems are considered to be the most important issues to the utilities [1]. Power systems are experiencing new sources and loads that differ qualitatively and quantitatively from the ones we had formerly. The necessity for an additional effectual utilization of the power grid without suffering consistency complications is becoming more understandable and significant. The operation of future power grid will face many challenges that are to be considered. With the new sources and loads, it will be very difficult to maintain the voltage stability of the power grid. Without an advanced automated wide area feedback control structure for regulating set-points of local area controllers, there is a chance that the deviation from schedule of the voltage, frequency, and line flows would exceed the acceptable ranges which would adversely affect the power system operation.

The instability of voltage has always been a main part of the crucial intimidations to the safety and reliability of the operation of power systems [2]. This instability occurs when the power grid is unable to maintain control of the voltage profiles. This phenomena might develop and propagate into the system and results eventually in a complete voltage collapse where blackouts occur [1]. To realize an additional proficient regulation of voltage through power grids, a harmonized voltage control scheme is developed. This scheme is a three level hierarchical control structure evolving of tertiary voltage

control method (TVCM), secondary voltage control method (SVCM), and primary voltage control method (PVC), has been suggested [2]. This hierarchal scheme was realized to be a fruitful method to guarantee the secure and stable power grids operation in some European countries [2-6]. The work presented in this paper discusses only the secondary voltage control method which has a significant role in sustaining the voltage profiles at adequate levels crossways the widespread power system by the appropriate modification of the grid-wide spread reactive power resources. Although, secondary voltage control has been realized long time ago, yet, to the best authors' knowledge, no PMU based SVCM has been implemented.

Many approaches have been developed to integrate secondary voltage method controllers in power systems [2-10]. In [7], certain key nodes of the grid known as the pilot nodes are monitored and the optimal secondary voltage control is accomplished over the results obtained by an over defined group of equations in the Chebyshev sense. Reference [8] introduces the same principle as in [7]; however, the use of PMU is presented. In [9], the authors present a novel adaptive wide area control method to power grids SVCM problem by the means of using synchrophasor measurements for the feedback measurements. The goal here is to maintain the whole system voltage profiles by suitable administration of reactive power resources in face of any unpredicted load turbulences. A drawback of this method is that it breaks the single optimization problem introduced in [2-7] into two separate cascaded optimization problems which makes this approach a bit inappropriate. In [10], SVCM is approached from a different perspective. The authors here investigate the applicability of zoning methodologies in adaptively determined reduced control model that can be used for SVCM. To the best authors' knowledge no work has been reported on the SVCM using different optimization techniques alongside with genetic algorithm based on PMU. On the other hand, all papers presented use generators of the grid as their primary controllers, but some have recommended the use of FACTS devices as a new primary controllers alongside the generators.

The employment of synchrophasor measurements units (PMUs) in power grids is becoming a central action presently [11-12]. As contrasted to the asynchronous, unprecise, and relaxed scope of the remote terminal units (RTUs) used in SCADA systems, a PMU device is able of delivering real time synchrophasor measurements attached by accurate time stamp via global positioning system (GPS) [13]. Through arrange these synchrophasor measurements' information according to the time stamps, the comprehensible image of the power grid out of this information is produced. A significant comment here

is that the employment of the incoherent information set in secondary voltage control method might consequence in a performance degradation of power grids [9]. Furthermore, because PMUs have advanced rate of information recording, sudden load turbulences, faults, systems oscillations, and emerging problems from integrating renewable energy resources could be handled. Many recent papers have suggested the use of PMUs to get the feedback measurements for the SVC [7, 8] [10-12]. However, none have provided a real time implementation of the proposed method. In other words, all of the previous works have been carried out using simulations, neither adopting actual PMUs nor considering PMU data flow in real time.

This paper introduces a real time implementation of SVC based wide area control (WAC) for grid's voltage regulation. This implementation is realized using Real Time Digital Simulator (RTDS) alongside with a MATLAB based program acting as a software in the loop. Furthermore, the paper presents a comparison between different solutions for the WAC including Genetic Algorithm (GA). The rest of the paper is structured as follows: Section II introduces the wide area control. Section III discusses the testing set up. Section IV shows illustrates and discusses the results obtained, and concluding remarks are drawn in Section V.

II. WIDE AREA CONTROL

The focus of this work is on the design of secondary voltage control method. Secondary voltage control method role is to receive the PMU measurements from the power grid and then send the set point as a reference voltage values to the primary local area controllers in the grid which could be the Automatic Voltage Regulators (AVRs) in generators units, the local controllers for the Flexible AC Transmission Systems (FACTS) devices, or any other power equipment that controls the voltage magnitude. The following figure shows the basic working principle of the wide area controller alongside the two basic local area controllers.

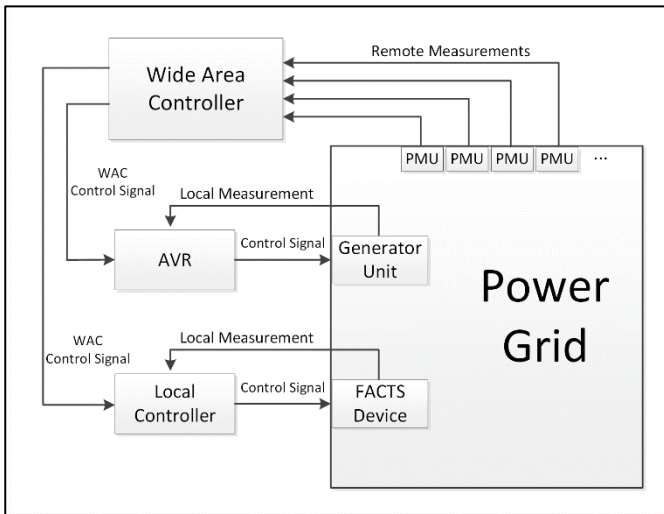

Fig. 1. Wide area control structure

In Fig. 1, the local control is the inner loop which is responsible to maintain the voltage of the local bus to the

reference voltage provided by the outer loop, the wide area control. Of course, both generators and FACTS devices can be used in reality; however, for the sake of simplicity and to quantify the effect of the WAC technique, this paper will consider only the use of one FACTS device without considering the generator units.

A. Mathematical Model

Wide area control deals with the slow behavior of the power grid. It assumes that the transient response of the primary controllers are stable and pretty fast. This control problem is not a familiar one as no system's natural dynamics are modeled; they are assumed instant. In other words, primary controllers shall have a much smaller time step than the wide area controller. According to this supposition, only steady state power flow equations are taken into consideration. A power system having different busses can be defined by a linear model nearby an operating point written as follows [14]:

$$\begin{bmatrix} \Delta P_1 \\ \vdots \\ \Delta P_n \\ - \\ \Delta Q_1 \\ \vdots \\ \Delta Q_n \end{bmatrix} = \begin{bmatrix} \frac{\partial P_1}{\partial \delta_1} & \dots & \frac{\partial P_1}{\partial \delta_n} & | & |V_1| \frac{\partial P_1}{\partial |V_1|} & \dots & |V_n| \frac{\partial P_1}{\partial |V_n|} \\ \vdots & \ddots & \vdots & | & \vdots & \ddots & \vdots \\ \frac{\partial P_n}{\partial \delta_1} & \dots & \frac{\partial P_n}{\partial \delta_n} & | & |V_1| \frac{\partial P_n}{\partial |V_1|} & \dots & |V_n| \frac{\partial P_n}{\partial |V_n|} \\ - & - & - & | & - & - & - \\ \frac{\partial Q_1}{\partial \delta_1} & \dots & \frac{\partial Q_1}{\partial \delta_n} & | & |V_1| \frac{\partial Q_1}{\partial |V_1|} & \dots & |V_n| \frac{\partial Q_1}{\partial |V_n|} \\ \vdots & \ddots & \vdots & | & \vdots & \ddots & \vdots \\ \frac{\partial Q_n}{\partial \delta_1} & \dots & \frac{\partial Q_n}{\partial \delta_n} & | & |V_1| \frac{\partial Q_n}{\partial |V_1|} & \dots & |V_n| \frac{\partial Q_n}{\partial |V_n|} \end{bmatrix} \begin{bmatrix} \Delta \delta_1 \\ \vdots \\ \Delta \delta_n \\ - \\ \frac{\Delta |V_1|}{|V_1|} \\ \vdots \\ \frac{\Delta |V_n|}{|V_n|} \end{bmatrix} \quad (1)$$

Where:

- P_i = Active power at node i
- Q_i = Reactive power at node i
- $|V_i|$ = Voltage magnitude at node i
- δ_i = Voltage phase angle at node i
- n = Number of system nodes

Equation (1) represents the famous Jacobian that is adopted in the power flow calculations which is based Newton-Raphson procedure. In large scale power transmission systems, an alternative strategy is used in order to increase the computational competence and decrease the computer storage requirements needed. This strategy is the decoupled power flow model which is based on the approximate version of the Jacobian used in Newton-Raphson procedure. This approximation is based on three facts:

- The change in the voltage phase angle δ at any bus affects mainly the active power P flow in power grids and leaves the reactive power Q flow relatively unchanged.

$$\frac{\partial P_i}{\partial \delta_j} \gg \frac{\partial Q_i}{\partial \delta_j} \cong 0 \quad (2)$$

- The change in the voltage magnitude $|V|$ at any bus affects mainly the reactive power Q flow in power grids and leaves the active power P flow relatively unchanged.

$$\frac{\partial Q_i}{\partial |V_j|} \gg \frac{\partial P_i}{\partial |V_j|} \cong 0 \quad (3)$$

- Line susceptances B are much larger than the line conductances G .

$$B_{ij} \gg G_{ij} \cong 0 \quad (4)$$

Applying these facts to the Jacobian leads to the following approximated decoupled model [14]:

$$\begin{bmatrix} \Delta Q_1 \\ \vdots \\ \Delta Q_n \end{bmatrix} = - \begin{bmatrix} B_{11} & \dots & B_{1n} \\ \vdots & \ddots & \vdots \\ B_{n1} & \dots & B_{nn} \end{bmatrix} \begin{bmatrix} \Delta |V_1| \\ \vdots \\ \Delta |V_n| \end{bmatrix} \quad (5)$$

$$\begin{bmatrix} \Delta P_1 \\ \vdots \\ \Delta P_n \end{bmatrix} = - \begin{bmatrix} B_{11} & \dots & B_{1n} \\ \vdots & \ddots & \vdots \\ B_{n1} & \dots & B_{nn} \end{bmatrix} \begin{bmatrix} \Delta \delta_1 \\ \vdots \\ \Delta \delta_n \end{bmatrix} \quad (6)$$

From (5) and (6), we get two approximately separate models of the system where we can deal with active and reactive powers in separate fashion.

B. Formulation of the Control Law

Since our interest is to control the voltage, we will only deal with the reactive power. Thus, it can be further detailed by separating it into controlled and uncontrolled busses as follows:

$$\begin{bmatrix} \Delta Q_c \\ \Delta Q_u \end{bmatrix} = - \begin{bmatrix} B_{cc} & B_{cu} \\ B_{uc} & B_{uu} \end{bmatrix} \begin{bmatrix} \Delta |V_c| \\ \Delta |V_u| \end{bmatrix} \quad (7)$$

where the subscripts c and u represent the voltage-controlled busses and the voltage-uncontrolled busses, respectively. From here, the following equations can be constructed:

$$[\Delta Q_u]^k = -[B_{uc}][\Delta |V_c|]^k - [B_{uu}][\Delta |V_u|]^k \quad (8)$$

$$[\Delta |V_u|]^{k+1} = -[B_{uu}]^{-1}([\Delta Q_u]^k + [B_{uc}][\Delta |V_c|]^{k+1}) \quad (9)$$

Where:

- $[\Delta |V_u|]$ = Difference between set-point (e.g. 1 pu) and measured voltage at uncontrolled nodes.
- $[B_{uu}]^{-1}[\Delta Q_u]$ = Reactive power disturbance at uncontrolled nodes.
- $[B_{uu}]^{-1}[B_{uc}][\Delta |V_c|]$ = Controlled voltage at controlled nodes.
- k = Current time step.

Consequently, the apparent control approach is to find a control action (changes in the set-point at voltage-controlled nodes) for the objective of minimizing the voltage deviation $[\Delta |V_u|]$ as shown below:

$$\min |-[B_{uu}]^{-1}([\Delta Q_u]^k + [B_{uc}][\Delta |V_c|]^{k+1})| \quad (10)$$

$$\text{subject to } V_c^{\min} \leq V_c \leq V_c^{\max}$$

This optimization problem is emerged from Multi Input Multi Output (MIMO) control applied at a networked system such as the power grid. In other words, each change in the set-point at any voltage controlled node will have an effect on every other voltage uncontrolled node of the system. However, this vary from one bus to the other depending on the electrical coupling between the nodes which known as the electrical distance. Since this optimization problem is very large and complex, there is a great need to look for fast and efficient optimization techniques which can give solutions within the time step of the wide area control.

C. Solving the Optimization Problem

This problem is known as multi objective optimization problem where we have more than one objective to consider

that are all related to the same variables as shown in the equation below.

$$\min (F(x)) = \min \begin{bmatrix} f_1(x) \\ f_2(x) \\ \vdots \\ f_n(x) \end{bmatrix} \quad (11)$$

The solution to this optimization problem is known as the Pareto optimal solution which represents the solution that cannot be improved in any of the objectives without degrading at least one of the other objectives. One main approach is known in order to solve this problem which is combining the all objective functions in one single function by adding all of the objective functions together in one main objective function.

$$\min_x \left| \sum_{k=1}^n f_n(x) \right| \quad (12)$$

In this paper, two methods are considered for solving this optimization problem. The first method is based on linear programming techniques which is called interior-point algorithm [15]. The second method is based on heuristic optimization techniques known as Genetic Algorithm [16].

III. TESTING SETUP

For testing the wide area controller a novel testing setup has been implemented. The concept of software-in-the-loop (SIL) is adopted here where the actual power system along with the primary controller are simulated in the Real Time Digital Simulator (RTDS) and the wide area controller is developed in MATLAB based program.

A. Power Grid Case with Designed Local Controller

In this paper, a standard IEEE 14 bus system has been used [17]. A FACTS device which is a Static Compensator (STATCOM) has been designed and connected to bus 13 [18]. Furthermore, PMUs have been optimally placed to have a full observability of the system. In other words, all busses of the system are observable by one PMU at least. Figure 2 shows the complete IEEE 14 bus power system model used in this study.

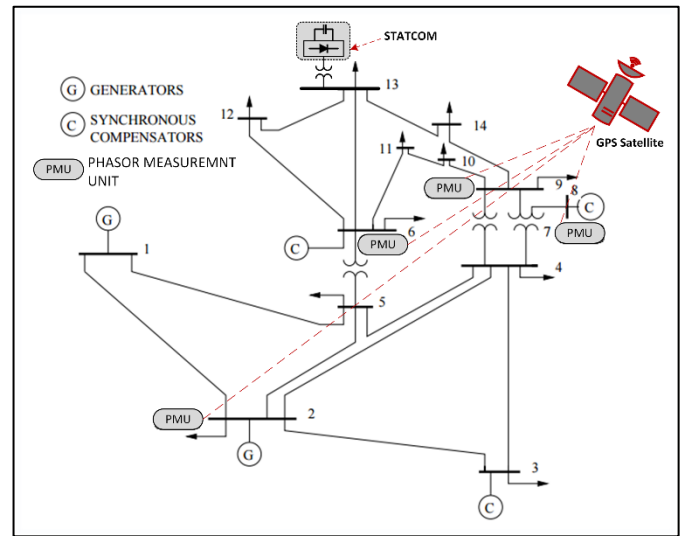

Fig. 2. IEEE 14 Bus System with STATCOM and Optimally Placed PMUs

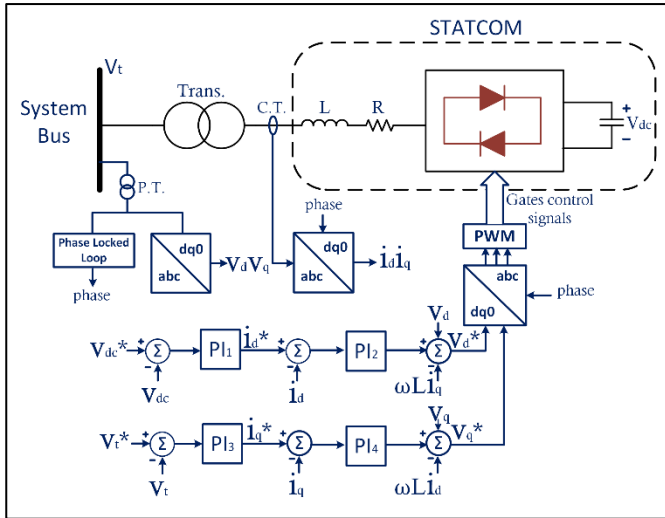

Fig. 3. PI based local area controller for the STATCOM

In order to control the STATCOM, a local PI based controller has been designed. The local controller receives the reference voltage V_t^* from the wide area controller and maintains it. Here, local measurements are used for the feedback. Figure 3 shows the designed PI local area controller for the STATCOM.

B. Software-in-the-loop (SIL) Setup

Real time digital simulator (RTDS) is a very powerful simulation tool for real time simulation. It can be used for Hardware-in-the-Loop (HIL) testing and Software-in-the-Loop (SIL) testing. It is considered as the most advanced simulation technology in power system research areas. With its parallel processing cards, it can simulate very large complicated systems in real time. For these purposes, it has been used in this study to simulate the power system and the local controller. Furthermore, the availability of PMU model, makes the RTDS a perfect tool to conduct PMU studies and testing. PMU model in RTDS is constructed based on standard IEEE C37.118.1-2011 [13], which makes it accepted to conduct research and studies using it.

However, since RTDS is designed intentionally for power system simulations, it is very hard to conduct the large mathematical operations for the wide area controller using it. From here, the idea of the SIL testing is adopted in this study. A MATLAB based program has been implemented as the software in the loop. Figure 4 shows the testing setup for the SIL designed. In this experiment, two unique RTDS cards have been used: GTSYNC which is used for synchronization (GPS 1PPS signal) of the PMUs, and GTNETx2 which is used for network communication using different protocols (GTNET_SKT, and GTNET_PMU). The first protocol was used to receive the wide area control action from the MATLAB program, and the second protocol was used to send the PMU messages to the MATLAB program according to the PMU standard IEEE C37.118.1-2011 [13]. On the other side, a novel MATLAB program has been implemented, which receives the PMU messages according to the PMU standard IEEE C37.118.1-2011 and send the wide area controller action to the RTDS.

IV. RESULTS AND DISCUSSION

To test the wide area control, a case has been created which includes different loads disturbances at different busses as well as a major under voltage at bus 8. The multi-objective optimization problem was solved in the MATLAB program using the two algorithms discussed earlier. A comparison has been conducted using the two cases alongside the case where only local control is used. Three main performance measures were used here: the average time consumed in solving the optimization problem, the average of the cost function value, and the root mean square value of the voltage deviation at all load busses.

$$MSE = \sqrt{\frac{1}{n} \sum_{i=1}^n (\Delta|V_i|)^2} \quad (13)$$

Where n and $\Delta|V_i|$ are the number of busses and voltage deviation at bus i , respectively. Figures 5 and 6 show bus voltages with the local area controller and with the wide area controller which looks almost the same for the two cases.

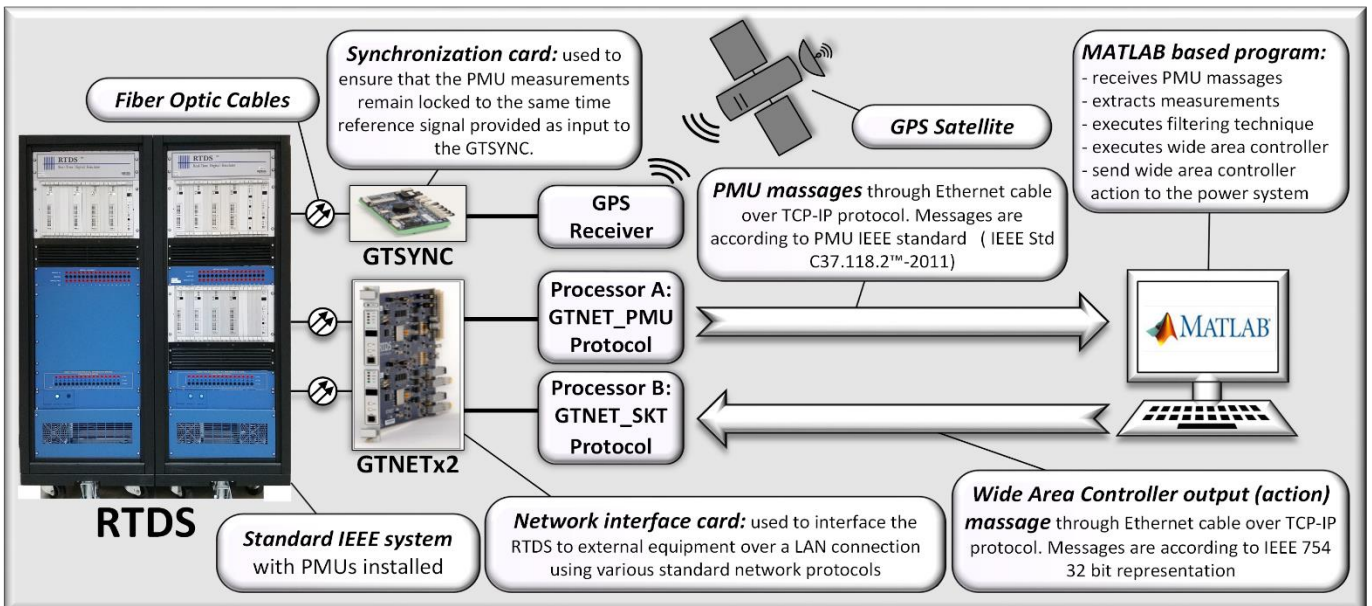

Fig. 4. Software-in-the-loop (SIL) testing with RTDS and MATLAB based program

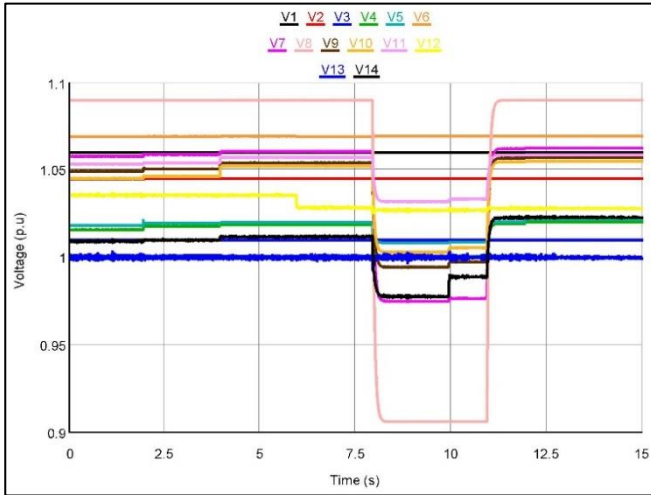

Fig. 5. RMS voltage of the 14 busses with local area controller; set-point is constant at 1 pu

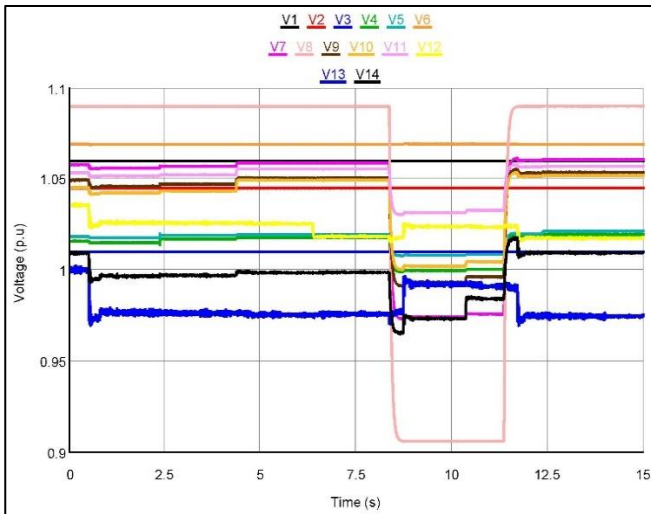

Fig. 6. RMS voltage of the 14 busses with wide area controller; set-point changes by the wide area controller

In Fig. 5, no WAC is used; thus the STATCOM reference signal is always at 1 pu (V_{13}) regardless of the disturbances in the system. However, when WAC is present (Fig. 6.), the set point for the STATCOM is changing with the objective of mitigating voltage deviations resulted from the disturbances in the system. Figure 6 illustrates the results obtained from the employment of the WAC based on Interior Point Algorithm. It is noted here that the results obtained from the Genetic Algorithm based WAC gave the same graphical voltage profile. In Fig. 6, a step in the voltage of bus 13 is noted at $t = 0.5s$ which is resulting from the initiation of the WAC system. Thus, both test cases (with and without WAC) start with the same initial conditions, but for the second test case, the WAC system is taking action at $t = 0.5s$. Once the WAC is operated, the voltage set point of the STATCOM is changed from 1pu to 0.97pu which would reduce the overall voltage deviation of the power grid. Many load disturbances were created for testing the WAC system. These disturbances are noted in Fig 5 and 6. For example, V_{14} is witnessing a load disturbance at $t = 10.5s$ which pushes the voltage up.

Table 1: Comparison of the Three Optimization Solving Methods

Control Type	Algorithm Used	MSE	Cost Function	Time (s)
Local Area Control	-	0.4476	-	-
Wide Area Control	Interior Point Algorithm	0.3962	0.1581	0.0809
	Genetic Algorithm	0.3982	0.1589	0.2572

However, since these disturbances are not major ones as the disturbance occurring at bus 8, no change in the set point of the STATCOM is seen for these small disturbances.

Table 1 shows the comparison of the two optimization solving algorithms discussed earlier. we can clearly see that wide area control provides a better performance compared to the local area control alone. Furthermore, interior-point algorithm is much faster for solving the optimization problem than the GA. The delay of the measurements is considered to be a main issue in WAC applications. The greater the delay of the measurements the slower larger the time step would be for the WAC system. In other words, the time step of the WAC system must be equal or larger than the combined time of the measurements recording, measurements delivering, WAC processing, and WAC set points delivering. Thus the communication delay plays a double role in the WAC systems. In this experiment, the communication medium between the PMUs and the WAC system is done over LAN network via Ethernet cables. This communication medium is very fast (in microseconds). Thus, no communication delay issues are presented. The main delay in this study is from two main sources: the measurements recoding and the WAC processing.

V. CONCLUSION

To accomplish an enhanced voltage control in power grids, a wide area secondary voltage control method built upon synchrophasor measurements was discussed. A novel software in the loop testing setup has been conducted in order to come up with realistic experimental case. With the new setup, wide area controller with different solving techniques have been evaluated. All of the techniques used provided an acceptable behavior by reducing the voltage deviation of the of the system busses. The genetic algorithm was found comparatively slow. With the developed setup, the wide area control studies can be extended to have more local controllers (generators, transformers tap changers, shunt capacitors, and FACTS devices), larger power system, and different advanced control approaches. Furthermore, local controllers might be replaced with actual components using hardware-in-the-loop (HIL), thus providing a more realistic testing setup and results. Another possible extinction of this work is evaluating the security feature of WAC systems. This area of interest has a very important role in wide area monitoring and control applications for its valuable need. The testing setup developed in this paper could be used for such wide area security studies such as bad data detection and rejection algorithms. The online applications of these algorithms are very important as it would open the door for real world industrial applications. These online applications are possible via this setup.

REFERENCES

- [1] P. Kundur, *Power System Stability and Control*, New York: McGraw-Hill, 1994.
- [2] S. Corsi, *Voltage Control and Protection in Electrical Power Systems: From System Components to Wide-Area Control*, Springer, 2015.
- [3] J. P. Paul, J. T. Leost and J. M. Tesson, "Survey of the secondary voltage control in France: Present realization and investigations," *IEEE Transactions on Power Systems*, vol. 2, no. 2, pp. 505-511, 1987.
- [4] S. Corsi, P. Marannino, N. Losignore, G. Moreschini and G. Piccini, "Coordination between the reactive power scheduling function and the hierarchical voltage control of the EHV ENEL system," *IEEE Transaction on Power Systems*, vol. 10, no. 2, p. 686-694, 1995.
- [5] H. Vu, P. Pruvot, C. Launay and Y. Harmand, "An improved voltage control on large scale power system," *IEEE Transaction on Power Systems*, vol. 11, no. 3, p. 1295-1303, 1996.
- [6] J. L. Sancha, J. L. Fernandez, A. Cortes and J. T. Abarca, "Secondary voltage control: Analysis, solutions, simulation results for the Spanish transmission system," *IEEE Transaction on Power Systems*, vol. 11, no. 2, p. 630-638, 1996.
- [7] J. S. Thorp, M. Ilic-Spong and M. Varghese, "An optimal secondary voltage-var control technique," *Automatica*, vol. 22, no. 2, p. 217-222, 1986.
- [8] Z. Liu and M. D. Ilic, "Toward PMU-based robust automatic voltage control (AVC) and automatic flow control (AFC)," in *IEEE General Meeting Power Energy Society*, Minneapolis, 2010.
- [9] H. Y. Su and C. W. Liu, "An Adaptive PMU-Based Secondary Voltage Control Scheme," *IEEE Transaction on Smart Grid*, vol. 4, no. 3, pp. 1514-1522, 2013.
- [10] V. Alimisis and P. C. Taylor, "Zoning Evaluation for Improved Coordinated Automatic Voltage Control," *IEEE Transactions on Power Systems*, vol. 30, no. 5, pp. 2736-2746, 2015.
- [11] J. D. L. Ree, V. Centeno and J. S. Thorp, "Synchronized Phasor Measurement Applications in Power Systems," *IEEE Transaction on Smart Grid*, vol. 1, no. 1, pp. 20-27, 2010.
- [12] A. Phadke and J. Thorp, *Synchronized Phasor Measurements and Their Applications*, Springer, 2008.
- [13] "IEEE Standard for Synchrophasor Data Transfer for Power Systems, IEEE Std C37.118.2™-2011," IEEE Power & Energy Society, New York, 2011.
- [14] J. J. Grainger and W. D. Stevenson, *Power System Analysis*, New York: McGraw-Hill, 1994.
- [15] G. B. Dantzig and M. N. Thapa, *Linear Programming 2: Theory and Extensions*, Springer, 2003.
- [16] K. F. Man, K. S. Tang and S. Kwong, "Genetic algorithms: concepts and applications," *IEEE Transactions on Industrial Electronics*, vol. 43, no. 5, pp. 519 - 534, 1996.
- [17] "Power System Test Case Archive," University of Washington, [Online]. Available: <http://www.ee.washington.edu/research/pstca/>.
- [18] X.-P. Zhang, C. Rehtanz and B. Pal, *Flexible AC Transmission Systems: Modelling and Control*, Springer, 2006.