

A STUDY ON INJECTION MOULDING AND INJECTION BLOW MOLDING TECHNOLOGY

Rajalingam Sokkalingam
Department of Science and Mathematics,
School of Engineering and Science,
Curtin University of Technology Sarawak, Malaysia
rajalingam@curtin.edu.my

Abstract: Injection moulding and blow moulding are probably the most widely used process for manufacturing parts by using plastic materials. A wide variety of products are manufactured by using these two technologies, which vary greatly in their size, complexity, and application. The injection moulding process requires the use of an injection moulding machine, raw plastic material and a mould. The process cycle for injection moulding consists of the following four stages: clamping, injection, cooling and ejection. Blow moulding is a manufacturing process that is used to create hollow plastic parts by inflating a heated plastic tube until it fills a mould and forms the desired shape. The manufacturing process is divided into three stages: injection, blowing and ejection. There are many types of materials that may be used in the injection moulding and blow moulding process. Most polymers may be used, including all thermoplastics, some thermosets, and some elastomers. Injection moulding industry is used to create many things such as milk cartons, packaging, bottle caps, automotive dashboards, pocket combs, and most other plastic products available today. Parts made from blow moulding are plastic, hollow, and thin-walled, such as bottles and containers that are available in a variety of shapes and sizes. This study is about the process, equipments, materials and applications involve injection moulding and blow moulding technology. At the same time it's also discuss about the advantage and disadvantage of both manufacturing technology.

Keyword: injection moulding, blow moulding, process, machine, materials and applications.

INTRODUCTION

Injection moulding - The most commonly used manufacturing process for the fabrication of plastic parts from both thermoplastic and thermosetting plastic materials. A wide variety of products are manufactured using injection

moulding, which vary greatly in their size, complexity, and application. The injection moulding process requires the use of an injection moulding machine, raw plastic material, and a mould. The plastic is melted in the injection moulding machine and then injected into the mould, where it cools and solidifies into the final part.[1] After a product is designed, usually by an industrial designer, moulds are made by a mould maker from metal, usually either steel or aluminium, and precision-machined to form the features of the desired part.

Blow moulding - Is a manufacturing process that is used to create hollow plastic parts by inflating a heated plastic tube until it fills a mold and forms the desired shape. The raw material in this process is a thermoplastic in the form of small pellets or granules, which is first melted and formed into a hollow tube, called the parison. There are various ways of forming the parison. The parison is then clamped between two mold halves and inflated by pressurized air until it conforms to the inner shape of the mould cavity. [2] The pressures are typically far less than for injection moulding pressures. Lastly, after the part has cooled, the mold halves are separated and the part is ejected.

PROCESS COMPARISON

Injection moulding

The process cycle for injection moulding consists of the following four stages: clamping, injection, cooling and ejection [3].

Clamping - Prior to the injection of the material into the mould, the two halves of the mould must first be securely closed by the clamping unit. Each half of the mould is attached to the injection moulding machine and one half is allowed to slide. The hydraulically powered clamping unit pushes the mould halves together and exerts sufficient force to keep the mould securely closed while

the material is injected. The time required to close and clamp the mould is dependent upon the machine - larger machines (those with greater clamping forces) will require more time. This time can be estimated from the dry cycle time of the machine.

Injection - The raw plastic material, usually in the form of pellets, is fed into the injection moulding machine, and advanced towards the mould by the injection unit. During this process, the material is melted by heat and pressure. The molten plastic is then injected into the mould very quickly and the build-up of pressure packs and holds the material. The amount of material that is injected is referred to as the shot. The injection time is difficult to calculate accurately due to the complex and changing flow of the molten plastic into the mould. However, the injection time can be estimated by the shot volume, injection pressure, and injection power.

Cooling - The molten plastic that is inside the mould begins to cool as soon as it makes contact with the interior mould surfaces. As the plastic cools, it will solidify into the shape of the desired part. However, during cooling some shrinkage of the part may occur. The packing of material in the injection stage allows additional material to flow into the mould and reduce the amount of visible shrinkage. The mould cannot be opened until the required cooling time has elapsed. The cooling time can be estimated from several thermodynamic properties of the plastic and the maximum wall thickness of the part.

Ejection - After sufficient time has passed, the cooled part may be ejected from the mould by the ejection system, which is attached to the rear half of the mould. When the mould is opened, a mechanism is used to push the part out of the mould. Force must be applied to eject the part because during cooling the part shrinks and adheres to the mould. In order to facilitate the ejection of the part, a mould release agent can be sprayed onto the surfaces of the mould cavity prior to injection of the material. The time that is required to open the mould and eject the part can be estimated from the dry cycle time of the machine and should include time for the part to fall free of the mould. Once the part is ejected, the mould can be clamped shut for the next shot to be injected.

After the injection moulding cycle, some post processing is typically required. During

cooling, the material in the channels of the mould will solidify attached to the part. This excess material, along with any flash that has occurred, must be trimmed from the part, typically by using cutters. For some types of material, such as thermoplastics, the scrap material that results from this trimming can be recycled by being placed into a plastic grinder, also called regrind machines or granulators, which regrinds the scrap material into pellets. Due to some degradation of the material properties, the regrind must be mixed with raw material in the proper regrind ratio to be reused in the injection moulding process.

Injection Blow moulding

In general, there are three types of blow moulding: Extrusion blow moulding, Injection blow moulding and Stretch blow moulding. These studies only focus on injection blow moulding (IBM). The injection moulding phase consists of injection moulding a thermoplastic material into a hollow, tube-shaped article called a preform. The preform is transferred on a metal shank, called the core rod, into a blow mould [4]. The process of injection blow moulding (IBM) is used for the production of hollow glass and plastic objects in large quantities. In the IBM process, the polymer is injection moulded onto a core pin; then the core pin is rotated to a blow moulding station to be inflated and cooled. This is the least-used of the three blow moulding processes. The process is divided into three steps: injection, blowing and ejection. The injection blow moulding machine is based on an extruder barrel and screw assembly which melts the polymer. The molten polymer is fed into a manifold where it is injected through nozzles into a hollow, heated preform mould. The preform mould forms the external shape and is clamped around a mandrel (the core rod) which forms the internal shape of the preform. The preform consists of a fully formed bottle/jar neck with a thick tube of polymer attached, which will form the body. The preform mould opens and the core rod is rotated and clamped into the hollow, chilled blow mould. The core rod opens and allows compressed air into the preform, which inflates it to the finished article shape. After a cooling period the blow mould opens and the core rod is rotated to the ejection position. The finished article is stripped off the core rod and leak-tested prior to packing. The preform and blow mould can have many cavities, typically three to sixteen depending on required output. There are three sets of core rods, which allow concurrent preform injection, blow moulding

and ejection. Each thermoplastic resin has its own set of tooling design parameters. Hot melt density, shrink factors, stretch ratios, blow pressure, venting criteria, and surface area of the tooling must all be known prior to designing any tooling[5].

EQUIPMENTS COMPARISON

Injection moulding machine

Injection moulding machines have many components and are available in different configurations, including a horizontal configuration and a vertical configuration. However, regardless of their design, all injection moulding machines [6] (figure 1) utilize a power source, injection unit, mould assembly, and clamping unit to perform the four stages of the process cycle [7].

Injection unit

The injection unit is responsible for both heating and injecting the material into the mould. The first part of this unit is the hopper, a large container into which the raw plastic is poured. The hopper has an open bottom, which allows the material to feed into the barrel. The barrel contains the mechanism for heating and injecting the material into the mould. This mechanism is usually a ram injector or a reciprocating screw. A ram injector forces the material forward through a heated section with a ram or plunger that is usually hydraulically powered. Today, the more common technique is the use of a reciprocating screw. A reciprocating screw moves the material forward by both rotating and sliding axially, being powered by either a hydraulic or electric motor. The material enters the grooves of the screw from the hopper and is advanced towards the mould as the screw rotates. While it is advanced, the material is melted by pressure, friction, and additional heaters that surround the reciprocating screw. The molten plastic is then injected very quickly into the mould through the nozzle at the end of the barrel by the build-up of pressure and the forward action of the screw. This increasing pressure allows the material to be packed and forcibly held in the mould. Once the material has solidified inside the mould, the screw can

retract and fill with more material for the next shot.

Clamping unit

Prior to the injection of the molten plastic into the mould, the two halves of the mould must first be securely closed by the clamping unit. When the mould is attached to the injection moulding machine, each half is fixed to a large plate, called a platen. The front half of the mould, called the mould cavity, is mounted to a stationary platen and aligns with the nozzle of the injection unit. The rear half of the mould, called the mould core, is mounted to a movable platen, which slides along the tie bars. The hydraulically powered clamping motor actuates clamping bars that push the moveable platen towards the stationary platen and exert sufficient force to keep the mould securely closed while the material is injected and subsequently cools. After the required cooling time, the mould is then opened by the clamping motor. An ejection system, which is attached to the rear half of the mould, is actuated by the ejector bar and pushes the solidified part out of the open cavity.

Injection blow moulding machines

In general, there are three stations in Injection blow moulding machines (Figure 2) to complete the process cycle: Preform mould station, Blown mould station and Stripper station. The process is divided into three steps: injection, blowing and ejection.

- Preform mould station: The preform is transferred on a metal shank, called the core rod, into a blow mould. The polymer is injection moulded onto a core pin; then the core pin is rotated to a blow moulding station to be inflated and cooled.
- Blown mould station: The preform mould opens and the core rod is rotated and clamped into the hollow, chilled blow mould.
- Stripper station: After a cooling period the blow mould opens and the core rod is rotated to the ejection position. The finished article is stripped off the core rod and leak-tested prior to packing.

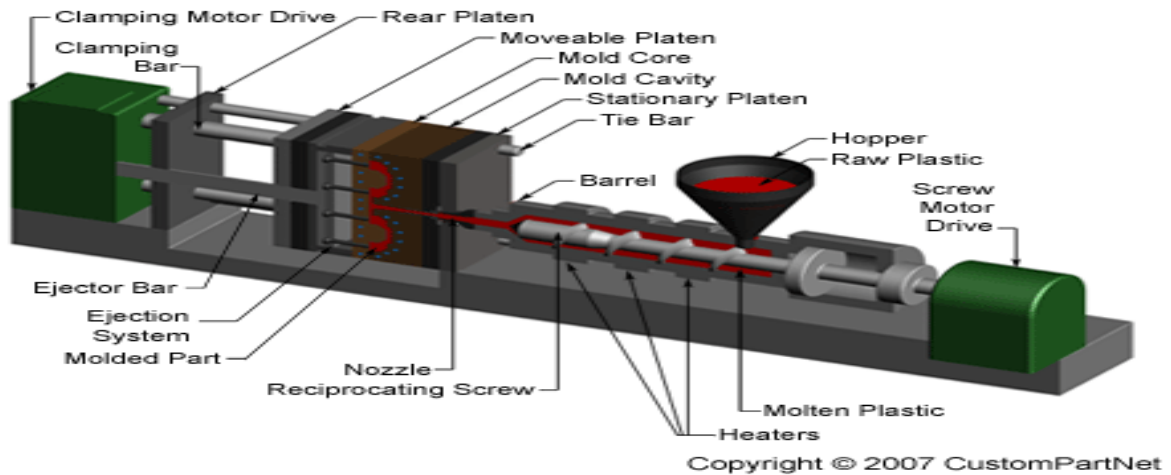

Figure 1: Injection moulding Machines

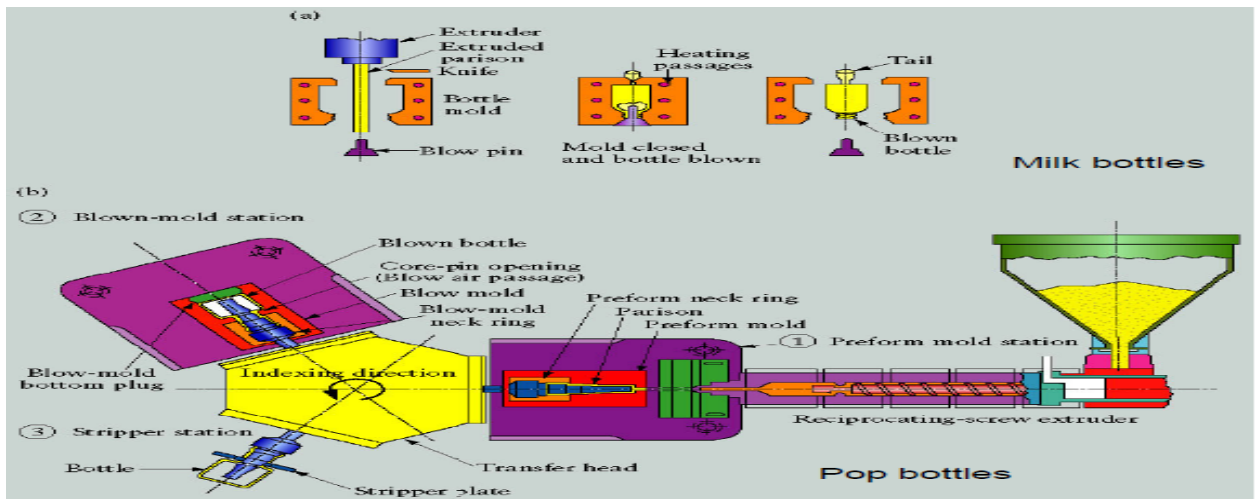

Figure 2: Injection Blow Moulding Machine

MATERIALS COMPARISON

There are many types of materials that may be used in the injection moulding and blow moulding process. Most polymers may be used, including all thermoplastics, some thermosets, and some elastomers [6]. The selection of a material for creating injection and blow moulded parts is not solely based upon the desired characteristics of the final part. While each material has different properties that will affect the strength and function of the final part, these properties also dictate the parameters used in processing these materials. Each material requires a different set of processing parameters in the injection moulding and blow moulding process,

including the injection temperature, injection pressure, mould temperature, ejection temperature, and cycle time.

Injection moulding parts can be formed from a variety of thermoplastic and thermosets materials, including the following:

- Acetal (POM)
- Acrylic (PMMA)
- Acrylonitrile Butadiene Styrene (ABS)
- Polyamide 11+12 (Nylon) (PA11+12)
- Polycarbonate (PC)
- Polyester – Thermoplastic (PBT, PET)
- Polyethylene - Low Density (LDPE)
- Polyethylene - High Density (HDPE)
- Polyphenylene Oxide (PPO)

- Polypropylene (PP)

Blow moulded parts can be formed from a variety of thermoplastic materials, including the following:

- Low Density Polyethylene (LDPE)
- High Density Polyethylene (HDPE)
- Polyethylene Terephthalate (PET)
- Polypropylene (PP)
- Polyvinyl Chloride (PVC)

APPLICATIONS

Injection moulding industry is used to create many things such as milk cartons, packaging, bottle caps, automotive dashboards, pocket combs, and most other plastic products available today including automotive, medical, aerospace, consumer products, toys, plumbing, packaging, and construction[8].

Parts made from blow molding are plastic, hollow, and thin-walled, such as bottles and containers that are available in a variety of shapes and sizes. This is the least commonly used method because of the lower production rate, but is capable of forming more complicated parts with higher accuracy. Small products may include bottles for water, liquid soap, shampoo, motor oil, and milk, while larger containers include plastic drums, tubs, and storage tanks.

CONCLUSIONS

Injection moulding is the most common method of part manufacturing compare to blow moulding. It is ideal for producing high volumes of the same object [9]. Some advantages of injection moulding are high production rates, repeatable high tolerances, the ability to use a wide range of materials, low labour cost, minimal scrap losses, can form complex shapes and fine details, excellent surface finish, and scrap can be recycled. Some disadvantages of this process are expensive equipment investment, potentially high running costs, and the need to design mouldable parts, [10] limited to thin walled parts and high tooling and equipment cost.

The material used in blow moulding part manufacturing is thermoplastics only but for manufacturing injection moulding part can use thermoplastics, composites, elastomer and thermosets. The advantages of blow moulding are can form complex shapes with uniform wall

thickness, high production rate, low labour cost, little scrap generated. The disadvantages are limited to hollow, thin walled parts with low degree of asymmetry, poor control of wall thickness, poor surface finish, few material options and high tooling and equipment cost.

RERERENCES

- [1] Norman C. Lee. "What Is Blow Moulding." Plastic Blow Moulding Handbook. Norman C. Lee. New York, United State. 1990. Pg 1-12.
- [2] Norman C. Lee. "The Basic of Blow Moulding." Blow Moulding Design Guide 2nd Edition. Norman C. Lee. USA. 2008. Pg 2
- [3]<http://www.custompartnet.com/wu/InjectionMoulding>
- [4] Norman C. Lee. "Extrusion Blow Moulding." Plastic Blow Moulding Handbook. Norman C. Lee. New York, United State. 1990. Pg 35
- [5] Norman C. Lee. "Injection Blow Moulding." Plastic Blow Moulding Handbook. Norman C. Lee. New York, United State. 1990. Pg 76.
- [6]<http://www.custompartnet.com/wu/InjectionMoulding>
- [7] Manufacturing Processes Reference Guide pg. 240
- [8] Douglas M. Bryce. Plastic Injection Moulding: Manufacturing Process Fundamentals. SME, 1996. pg.1-2
- [9]<http://www.yaskawa.com/site/Industries.nsf/applicationDoc/appinjmold.html>, 02/27/09
- [10] <http://www.what-is-injection-molding.com/Default.aspx?tabid=36>, 02/27/09