

School of Education

**Oral communication strategies instruction:
Voices from Indonesian English language lecturers**

Abid

**This thesis is presented for the degree of
Doctor of Education
of
Curtin University**

December 2016

Declaration

To the best of my knowledge and belief this thesis contains no material previously published by any other person except where due acknowledgment has been made.

This thesis contains no material which has been accepted for the award of any other degree or diploma in any university.

The research presented and reported in this thesis was conducted in accordance with the National Health and Medical Research Council National Statement on Ethical Conduct in Human Research (2007) – updated March 2014. The proposed research study received human research ethics approval from the Curtin University Human Research Ethics Committee (EC00262), Approval Number #EDU-156-14.

Signature:

A handwritten signature in black ink, appearing to read 'A. Shali', followed by a horizontal line extending to the right.

Date: 14 December 2016

Acknowledgement

I would like to express my gratitude to Allah SWT, the Almighty God, who has given me His blessings to complete this four years of doctoral degree study. I would also like to take this opportunity to express my deepest appreciation to particular individuals and institutions for assisting me in completing my study. First of all, my sincere thanks to my supervisors, Dr. Paul D. Mercieca and Dr. Toni J. Dobinson, who have patiently assisted and guided me in my thesis writing. I would also like to acknowledge the assistance of Dr. Ilan Zagoria, who became my co-supervisor during the completion of my candidacy proposal.

I wish to thank my sponsor, the Directorate General of Higher Education in Indonesia, who granted me the DIKTI Scholarship, enabling me to pursue a doctoral degree at Curtin University. My special thanks also to my colleagues at the Department of English Education at the *Universitas Negeri Gorontalo*, Indonesia, and all the pre-service teachers majoring in the department who voluntarily participated in my research.

I am thankful to Dr. Anna Alderson, who has helped me polish my academic English writing. Her feedback on my thesis drafts has allowed me to make improvements in my English language academic writing. Her memory will always be with me. I also want to thank Prof. Rhonda Oliver, Assoc./Prof. Lina Pellicione and Mrs. Kerry Goodwin for being so supportive in all matters related to my study at Curtin University. In addition, professional editor, John McAndrew, provided copyediting and proofreading services, according to the guidelines laid out in the university-endorsed national 'Guidelines for editing research theses'.

To my late father, Drs. Idrus Halim, M.Si, and my mother, Aisa Kyai Baderan, S. Pd., I am thankful. During their prayers, I believe, they have endlessly asked Allah SWT for His blessings, which enabled me to reach this highest stage of academic life. Thank you very much to my parents in law, Prof. Dr. R. Agus Sartono, MBA and Dina Pristiani, S.H., who have also generously supported me in so many ways. Last but not least, I would like to thank my wife, Citra Aditya Kusuma, B.Com, MIB and my little one, Zafran Akhtar Halim, for their endless support and prayers.

Abstract

Oral communication strategies (OCS) have been seen as learning tools that language learners can use to deal with difficult situations when communicating orally in the language they learn. In the context of English language learning, studies have focused on strategy use by learners or the role that strategies play for learners attempting L2 oral interaction. The literature reviewed in this present study showed that there are only a limited amount of studies focusing on lecturers' perspectives about strategies instruction in the context of an English Education Program in an English as a foreign language country, such as Indonesia, and that the area remains largely unexplored. The English Education Program aims at educating potential school English language teachers in Indonesia. Given this, it is relevant and apt to conduct this present study to respond to the growing needs of English language teachers in Indonesia.

This study sought to investigate the perspectives of English language lecturers on OCS instruction in an English Education Program in Indonesia. A university located in the north of the country, where the researcher works as a lecturer, was selected for the study. All lecturers teaching speaking and listening were invited to participate in the study. The researcher used an individual face-to-face semi-structured interview method to collect data from the lecturers, and corroborated the data with analysis of PSTs' responses obtained from individual face-to-face semi-structured interviews, teaching syllabuses and classroom observations. The interviews with the lecturers and their PSTs were conducted in English and Indonesian and analysed using a thematic analysis approach, informed by a constructivist paradigm.

The present study widened out to provide a description of the lecturers' responses to four guiding questions. These aimed to elicit the lecturers' objectives in teaching oral communication, the lecturers' perspectives on oral communication challenges experienced by their PSTs, how the challenges are handled, and whether or not lecturers encouraged the use of OCS in and outside classes. While findings in these areas were rich, lecturers lacked adequate understanding of OCS (e.g. types and functions), and therefore could not report in any depth on their encouragement of the use of the strategies by their PSTs. They were unaware of how to teach them and lacked appreciation of their relevance and usefulness to the English Education Program and the PSTs.

Table of Contents

Declaration	ii
Acknowledgement	iii
Abstract	iv
Table of Contents	v
List of Figures.....	viii
List of Tables	ix
Chapter 1 Introduction	1
1.1 <i>Background to the study</i>	1
1.1.1 English as a global language.....	1
1.1.2 Communication breakdowns between additional language learners.....	3
1.1.3 Oral communication strategies	5
1.2 <i>Context to the study</i>	6
1.2.1 The educational system in Indonesia at all levels	7
1.2.2 English teaching in Indonesia.....	10
1.2.3 English Language Teacher Education (ELTE)	13
1.2.4 Department of English Education.....	14
1.2.5 The Faculty of Letters and Culture	15
1.2.6 English teaching in the Faculty of Letters and Culture	17
1.3 <i>Purpose of the study</i>	17
1.4 <i>Research design</i>	19
1.4.1 Research questions	19
1.4.2 Scope of study	20
1.5 <i>Significance of the study</i>	20
1.6 <i>Conceptual framework</i>	21
1.7 <i>Organisation of the thesis</i>	23
1.8 <i>Summary</i>	23
Chapter 2 Literature Review.....	24
2.1 <i>English in the world</i>	24
2.2 <i>Teaching English in an international context: objectives, challenges, and responses</i>	28
2.2.1 Objectives in teaching English	29
2.2.2 Challenges in teaching English.....	31
2.2.3 Overcoming challenges in teaching English.....	33
2.3 <i>Relevant conceptual areas to language teaching and learning</i>	35
2.3.1 Sociocultural theory	35
2.3.2 Critical language pedagogy	37
2.3.3 World Englishes	40
2.3.4 Psycholinguistics	43
2.3.5 Language teacher cognition.....	47
2.4 <i>Approaches in language teaching</i>	49
2.4.1 Communicative language teaching.....	49
2.4.2 Task-based language teaching	50
2.4.3 Content and language integrated learning and content-based instruction	52

2.4.4	Post-method approaches	57
2.5	<i>Language learning strategies</i>	58
2.5.1	Oral communication strategies	60
2.6	<i>Summary</i>	65
Chapter 3	Research Methods	66
3.1	<i>Research purpose and orientation</i>	66
3.2	<i>Applying qualitative research design</i>	67
3.3	<i>Data Collection</i>	68
3.3.1	Participants	68
3.3.2	Sources of data	71
3.3.3	Data analysis	76
3.4	<i>Trustworthiness</i>	78
3.5	<i>Ethical issues</i>	79
3.6	<i>Summary</i>	80
Chapter 4	Findings	81
4.1	<i>Lecturers' objectives in teaching English oral communication</i>	81
4.1.1	Teaching to improve own learning	82
4.1.2	Improving PSTs' English language speaking skills	83
4.1.3	Improving PSTs' English language listening skills as a vehicle to improved L2 oral communication	85
4.1.4	PSTs develop their confidence in speaking English	87
4.1.5	Helping PSTs to pass the oral component of the TOEFL	87
4.2	<i>Lecturers' perspectives of pre-service teachers' (PSTs) English oral communication challenges</i>	90
4.2.1	Linguistic proficiency challenges	91
4.2.2	Psychological challenges	94
4.2.3	English language engagement opportunity challenges	97
4.2.4	Background knowledge challenges	100
4.3	<i>Techniques and strategies used by lecturers to cope with PSTs' English oral communication challenges</i>	101
4.3.1	Setting up classroom activities	102
4.3.2	Setting up group work	103
4.3.3	Tolerating and encouraging the use of L1	105
4.3.4	Encouraging independent learning	107
4.3.5	Using strategies for extending speaking turns	108
4.4	<i>Do the lecturers encourage the PSTs to use English oral communication strategies in and out of classes?</i>	111
4.5	<i>Summary</i>	114
Chapter 5	Discussion	115
5.1	<i>Objectives in teaching English oral communication</i>	116
5.2	<i>English oral communication challenges in the context of the English Education Program in Indonesia</i>	124
5.3	<i>Techniques and strategies employed by the lecturers to deal with English oral communication challenges</i>	130
5.4	<i>Lecturers' encouragement for PSTs to use English oral communication strategies in and out of lectures</i>	139
5.5	<i>Summary</i>	141
Chapter 6	Conclusion	142

6.1	<i>Overview of key findings</i>	142
6.2	<i>Pedagogical implications and recommendations</i>	145
6.3	<i>Implications for further research</i>	147
References		149
Appendix 1		166
Appendix 2		168
Appendix 3		172

List of Figures

Figure 1 Conceptual framework	22
Figure 2 Phases of OCS instruction (adapted from Maleki, 2007, p. 593)	63

List of Tables

Table 1 OCS classification (adapted from Dörnyei, 1995, p. 58)	62
Table 2 Key and guiding research questions	68
Table 3 Participants' profile (the lecturers)	70
Table 4 Participants' profile (the pre-service teachers)	71
Table 5 Transcription conventions	78
Table 6 Key and guiding research questions	81
Table 7 Objectives in teaching English oral communication	82
Table 8 Lecturers' perspectives of PSTs' English oral communication challenges	91
Table 9 Teaching techniques and strategies used by lecturers to cope with the PSTs' English oral communication challenges.....	102
Table 10 Oral communication challenges classification.....	125

Chapter 1

Introduction

This chapter describes the background and context to the present study, as well as the purpose and the research design of the study. In addition, it outlines the significance and the conceptual framework of the study, and the organisation of the thesis.

1.1 Background to the study

There are three key sub-sections in this background, which begins with a brief overview of how the term English as a global language informs current English language teaching (ELT) practices in Indonesia. This is followed by an introduction to how certain types of communication breakdowns commonly occur among language learners and how they can compromise effective ELT in Indonesia. Oral communication strategies (OCS) are also explored in this section with regard to how they might help ELT practitioners and learners to integrate them into their practices.

1.1.1 English as a global language

The term English as a global language from a demographic perspective can be defined as a language whose speakers are from different parts of the world. For these speakers, the language may serve as their primary means of communication, whereas for others it is an additional language. As its use increases there are impacts not only for its speakers, but also for learners of the language. Some examples of these impacts are on the ownership of English as the first language and English language learning and teaching in linguistically different contexts. In particular, it is the latter which has encouraged extensive discussion-among ELT scholars around the world.

In the context of the growing needs of learning other languages used widely in the world, such as Arabic and Chinese, learning English remains important for at least two reasons. First, English is recognised as a global language, characterised by various factors, such as the increasing number of its speakers (Canagarajah, 2007) and its privilege as the official language of many worldwide organisations (Kirkpatrick, 2008). Second, English has been adopted amongst a diverse community of users (e.g. traders, soldiers, and settlers) and in many different modes, such as

newspapers, magazines, and television (Phillipson, 2008). Increases in the use of English tighten a mutual relationship between countries in the world in many aspects of life. Learning English becomes a powerful tool for gaining access to technology and world knowledge (Kam, 2002).

When learning English for an additional language (either in a second or foreign language context), learners may have different purposes. Some of the purposes are for travelling to other countries where English is the primary means of communication in these countries. Additional purposes are to conduct business with people who speak English, and for accessing global information (Fatiha, Sliman, Mustapha, & Yahia, 2014). In the Indonesian context, as reported by the Indonesian English schoolteachers, Indonesian learners of English share similar purposes, namely, to communicate with people from other countries and to cope with the globalisation era (Zacharias, 2003). Learning the language for educational purposes is also evident in Indonesia as the curriculum mandates teaching the language as a compulsory school subject for the learners (Lie, 2007; Sahiruddin, 2013).

One of the impacts of the increasing role that English plays in the world is that many countries, especially in Asia, make English language learning compulsory. Kam (2002) stated that in countries such as Cambodia, China, Indonesia, and Japan, English is integrated into the school curriculum and taught as a foreign language. Although each of these countries has its own motives for recommending English tuition at the school level, the spread of English language learning is mainly for pragmatic reasons (Kam, 2002). In Indonesia, for instance, secondary school students learn English not only in preparation for their college years, but also for “securing a favourable position and remuneration in the job market” in their future careers as they graduate from college or universities (Lie, 2007, p. 3). To this end, developing the skills that enable English language learners to use the language with ease for communicative purposes becomes imperative.

To be able to communicate successfully using English in contexts which involves speakers of different first languages, English learners need to pay attention to some key issues. One of the issues is the need to be intelligible when communicating orally (Yamaguchi, 2002). Though the term can be interpreted differently at the individual

level, there is a consensus that to be intelligible, language learners should be able to produce clear articulation of their messages. Many English speakers, however, speak English in their own ways, keeping influences from their first language, such as pronunciation. Much current research supports the development of English language learners' skills in managing oral communication in order to understand the culture of other speakers of English. As Canagarajah and Ashraf (2013, p. 280) point out, "language awareness is combined with intercultural competence". One example of this language awareness is the need for language teachers and students-to be aware of the richness of the linguistic features (e.g. lexical items and pronunciation) of English learners' first languages and their influence on their use of English for communication purposes.

If intercultural competence is influential in developing L2 learners' oral communication skills, there remains a question to answer: In which culture do learners need to be competent? Speakers of English language are people who come from countries where English is not the primary means of communication. These people use English as an additional language to serve multiple purposes. With this in mind, communicative situations involving these English users can be problematic because of the pragmatics of such situations (Cheng, 2012). What teachers can do is to raise awareness of the existence of different cultural values of English speaking individuals in their language learning (Cheng, 2012; Mirzaei & Forouzandeh, 2013). This can help the learners find ways to improve the quality of their involvement in L2 communication, including how to handle potential communication breakdowns that can happen when interacting with people from different linguistic backgrounds.

1.1.2 Communication breakdowns between additional language learners

Communication breakdowns, especially during oral interaction in the target language, have various forms. The most common of these is that one speaker misunderstands what the other speaker has said. Such misunderstanding can result in speakers being unable to provide correct responses. A specific example of this can be seen when students are presenting a paper at a conference; oral communication breakdowns arise as the presenter fails to comprehend questions from the audience,

hence, giving answers which do not correspond to what they are being asked. On some occasions, oral communication breakdowns stem from the person's lack of skills in reacting to others (Dörnyei & Scott, 1997; Tarone, 1981).

Oral communication breakdown can also occur in situations where speakers communicate a message in a way that is difficult to understand by others. This difficulty is usually influenced by the specific linguistic features of the speakers' language. In many cases this includes vocabulary and pronunciation which is only recognised and used within the speakers' community. Kirkpatrick (2007) refers to this influence as the use of a variety or register of language in a specific communicative situation to perform a certain function. Kirkpatrick (2007) gives an example of the Australian who will try to sound less Australian when talking to his business counterparts from Singapore, but is very likely to use many specific features of Australian vocabulary when talking on the phone with his or her family. The occurrence of oral communication breakdown is not only attributed to a lack of English linguistic competence, but also to the use of a variety of linguistic features of English that are exclusive to and recognised by a particular English speaking community (Cheng, 2012).

Specificity in the linguistic features of the English language, such as that of Singapore English, Malaysian English, or the English language spoken by Indonesians and Thai speakers, for instance, does not demote the status of English because of its non-conformity with the English language spoken largely by monolingual English speakers and taught in many English classrooms. Singapore English, for example, is the result of the spread of English into multicultural communities (Kirkpatrick, 2007). It has formed a new, established English linguistic community whose language serves as the national language of the country and which is recognised in English language teaching literature. Modiano (2009) sees this emerging variety of English in many parts of the world as beneficial to defining how English shall be used within linguistically and geographically different communities.

Given that today's English oral communication may involve speakers of English from multiple linguistic backgrounds and various English-speaking countries, it follows that breakdowns in such communication often occur. These breakdowns may

be minor or major. For English language learners, it can be a demanding task to manage breakdowns in communication. These learners are often working with unfamiliar vocabularies or difficult pronunciation when interacting in English with individuals who speak a different variety of English. In handling such breakdowns when communicating with people from a similar linguistic background, for instance, language learners may handle such breakdown with less effort than required during conversation in a second or third language. Communicating orally using an additional language, especially for beginner English learners, either with or without someone else as the interlocutor, requires a lot more preparation than in the learners' daily language.

In the context of Indonesia, research in the ELT arena shows that the practice of teaching English continues to pose a variety of challenges, particularly in the area of oral communication skills (Mustafa, 2001; Lie, 2007; Zein, 2014). Teachers' competence, students' proficiency levels, and teaching approaches are some of the most influential factors in the success of language teaching in many language classrooms. In fact, as Jones (2004) has suggested, the psycholinguistic barriers of the learners, such as speaking anxiety, might affect students' performance in the classroom and compromise effective language teaching. The influence of such factors in teaching oral communication in the English classroom has long been a topic of discussion amongst English language researchers. To address these factors in the classroom, researchers propose different inputs to language pedagogy. One such input involves "oral communication strategies" (Tarone, 1981), subsumed under Canale and Swain's (1980) "strategic competence".

1.1.3 Oral communication strategies

Oral communication strategies (OCS) are the strategies that a language learner can use to find ways to overcome their linguistic challenges. Some examples of the use of OCS are the use of topic avoidance, circumlocution, code switching, appealing for help, and hesitation devices. Although researchers have considered these strategies as serving different functions (see for example, Tarone, 1981; Bialystok, 1990; Smith, 2003), Jamshidnejad (2011) has asserted that the use of OCS should be considered a means to help language learners find ways to convey meaning, to negotiate a

conversation, and to reach a communicative goal by managing their linguistic deficiencies.

Even though a number of earlier researchers recognised some potential benefits of teaching OCS to learners of English (e.g. Littlemore, 2003; Rabab'ah & Bulut, 2007; Omar, Embi, & Yunus; 2012), there were other voices which suggested that teaching these strategies might not be necessary because learners could learn to use their own strategies by themselves (e.g. Kellerman, 1991). However, there remains some support for instruction in these strategies (e.g. Azian et al., 2013; Dörnyei, 1995; Jamshidnejad, 2011; Nakatani, 2012;). Nakatani (2012), for instance, contends that OCS instruction helps learners find ways to maintain involvement in conversation by negotiating and becoming more aware of adjusting their speech once they know that their interlocutors are signalling negotiation.

While debates on OCS instruction continue, mainly in the context where English is learnt for daily communication purposes, these debates are rarely found in Indonesia, a country in which English is predominantly learnt not for the purpose of daily communication, but for such purposes as education and employment. In fact, research that examines lecturers' perspectives on teaching some of the strategies in the context of English Education programs is rare. Thus, investigating lecturers' perspectives in this present study will provide valuable feedback for those contemplating incorporating the teaching of these strategies into their English language curriculum. Because the current 2013 school curriculum also stipulates the improvement of communicative competence, where oral communication strategies are subsumed in this competence, it becomes imperative for Indonesian school teachers to address such improvement in their ELT classrooms to ensure school graduates possess adequate skills to speak English. This also applies to Indonesian English language lecturers at university level, whose role in providing Indonesian schools with competent English language teachers is vital.

1.2 Context to the study

This section describes the educational system in Indonesia and outlines both English language teaching (ELT) practices and English language teacher education.

1.2.1 The educational system in Indonesia at all levels

The educational system in Indonesia is explicitly mandated in the Law of the Republic of Indonesia Year 1945 Chapter 31. This system constitutes different aspects. First and foremost, each Indonesian deserves the opportunity to enjoy schooling at all levels of education, and the government of Indonesia shall bear the responsibility in designing a system that can be applied nationally. Second, it also states that the government of Indonesia must allocate approximately twenty percent of its state budget to fund the implementation of national education. Third, this implementation aims to foster the development of technology and science for the prosperity of all Indonesians, informed by religious values and the unity spirit of Indonesia. This law supports the principal framework that guides the implementation of educating Indonesians at all levels.

In 2003, the government of Indonesia issued a law that regulated various aspects of Indonesian education, such as level of education, curriculum and teachers (Law Number 20 Year 2003). The former aspect, which is further stipulated in the Government Regulation Number 47 Year 2008 on Complementary Education, entails formal, non-formal, and informal education. This regulation suggests that formal education includes education at the primary (Year 1 to 6) and secondary (Year 7 to 9) level, and that all Indonesians are required to complete both levels. Before they can go to university to pursue an undergraduate or diploma level degree, Indonesians have to finish upper secondary school (Year 10 to Year 12) (Lauder, 2008). At the university level, the completion of an undergraduate degree normally takes about four years, whereas a diploma ranges from one to three years.

Non-formal education, on the other hand, aims to support Indonesians in finding alternative or additional sources of formal education. It seeks to develop learners' potential by focusing on mastering knowledge and functional skills, and working to improve their attitude and professional personality, such as in early childhood education, life skills education and literacy education. The outcome of attending this type of education, such as in community-based study groups, can be recognised as being on the same level with formal education as long as a particular form of assessment is undertaken.

As reported by Statistics Indonesia in 2014, there are approximately 171,000 elementary schools, 51,000 junior high schools (Year 7 to 9), and 19,000 senior high school (Year 10 to 12) in Indonesia. All these schools are located in the 34 provinces in Indonesia, an archipelagic country in Southeast Asia, consisting of a population of approximately 242 million people with more than 2000 ethnic groups (Firman & Tola, 2008). This information shows that the implementation of national education in Indonesia is influenced by multiple factors.

The second aspect of the law explains various issues, such as the type of curriculum that the schools should employ, how it is developed and implemented by the schools, and how the national examination should be executed. The Indonesian school curriculum has undergone a number of changes. Wijaya (2008) reported that Indonesia has changed its curriculum over the past twenty years. In 2006, the so-called Curriculum 2006 was implemented, replacing the former Curriculum 2004. The implementation of this curriculum is regulated under the Law Number 20 Year 2003 and targets all school levels, whilst universities continue to use Curriculum 2004 (Wijaya, 2008). One of the differences between these two curricula is that in the Curriculum 2006 there were more parties involved in the design of the syllabi, such as parents and school committees, than in the Curriculum 2004, which was known as a competence-based curriculum (Wijaya, 2008).

It is evident that this relatively quick change of curriculum took place for some key reasons. Sahiruddin (2013, p. 570) argued that there was a need to incorporate “the role presence of local authority” in the curriculum which encouraged the Indonesian government to design and implement the 2006 curriculum. Yet, the implementation of this curriculum still posed a number of challenges (Sahiruddin, 2013), which lay in different sectors. These comprised students overloaded with subjects, over-reliance on teacher-oriented approaches, and teachers understanding curriculum implementation in different ways (Sahiruddin, 2013). The Indonesian government formulated the 2013 curriculum to address these continuing challenges. The 2013 curriculum is known as a character-based education curriculum.

These changes in curriculum have had some consequences, affecting the implementation of teaching and learning processes at the school and university level.

One of the consequences is related to learners. In the ELT sector, for instance, Wijaya (2008) asserts that learners can best learn English in an integrated way. This means they are taught the language to improve not only receptive skills (e.g. reading and listening), but also productive skills (e.g. writing and speaking). In fact, the curriculum enabled the teachers to become more creative and to provide a stimulating and enjoyable learning environment both in and outside the classroom. The learners, on the other hand, are encouraged to be more responsible for their own learning by seeking any opportunities outside the classroom to learn and practise using English (Wijaya, 2008). Despite this sound description of ELT pedagogy, the outcomes remain questionable because of different impinging factors, such as the national examination, teachers' competence and learning resources.

The Indonesian government has decided not to treat the national examination as the only factor which determines school graduation. This new regulation is mandated in the Government Regulation Number 13 Year 2015. In the past, debate about supporting or rejecting the examination was intense, but the opinions proposed often lacked empirical evidence (Furaidah, Saukah & Widiati, 2015). It is believed that this regulation is motivated by the growing concern about the negative impacts of the examination on Indonesian students, as well as on teachers and schools (Hamied, 2012). The national examination has driven many teachers, in particular, to focus mostly on helping the test takers (the students in Year 6, 9, and 12) to pass the test (Lamb & Coleman, 2008; Sukyadi & Mardiani, 2011). In short, the examination dictates the practise of teaching and learning in the classroom (Sukyadi & Mardiani, 2011).

The third aspect of the law is related to teachers. This law suggests that Indonesian school teachers and lecturers are required to demonstrate skills related to cognitive, affective and psychomotor aspects to teach. Accordingly, for teaching at the school level, the teachers must have a degree equivalent to a bachelor degree, and for higher education a master's degree. At the elementary school level, teachers are generally from the Department of Elementary School Teacher Education, whilst at the secondary level, they are from universities that specialise in teacher education (Zein, 2014). However, graduating student teachers from other streams of bachelor degrees may apply for teacher positions as long as they have attended a particular teacher

candidate training hosted by certain higher institutions. Having attended the training, they are given a certificate that enables them to become teachers.

Today, many teachers at all school and higher education levels have attended the Indonesian government professional upgrade program called, 'Teacher and Teacher Educator Certification'.

1.2.2 English teaching in Indonesia

The teaching of English as a foreign language in Indonesia has taken place since Indonesia proclaimed its independence in 1945. From a historical perspective, ELT in Indonesia is unique in the sense that the Indonesian government decided to choose teaching English as a foreign language rather than Dutch, a language that remained in contact with the Indonesian language for more than three decades during the Dutch colonisation (Lie, 2007). The major reason for this language selection could be the role English plays in the world in many aspects, such as technology and economic development (Lauder, 2008; Crystal, 2003).

In Indonesia, ELT plays a significant role. The English language is included in the Indonesian national curriculum as a foreign language subject (Sahirudin, 2013). Other languages may not be given this same status, such as Chinese and Japanese, except for Arabic, which is learnt compulsorily by the students studying in the Islamic-based schools (Lauder, 2008). As a language subject, English has been taught at all school levels, from elementary to secondary level. However, at the elementary level, not all schools teach English. The reasons for this are the availability of English language teachers and the schools' readiness to provide English language materials. This is particularly the case in elementary schools located in rural areas. While many schools in urban areas have teachers of English whose expertise is in teaching the language, schools in rural areas usually do not. At the elementary level, English is usually taught by classroom teachers (Zein, 2014), although in some schools the content subject is also delivered by English language teachers.

The status of English as a language subject varies according to the level of education. At the elementary level, this subject is learnt voluntarily. According to Yulia (2013)

from Year 7 to 12, learning English is compulsory for all the students because in the national examination this language is tested. This means unless the students pass the test, they may find it difficult to meet the graduating requirements. This situation applies to all students in Year 9 and 12. Year 9 students need to pass the English test for entry into Year 10; whereas Year 12 students are required to take the test so that they can pass schooling and prepare for higher education (Yulia, 2013). In high school, particularly in Year 11, students are encouraged to choose study programs that suit their interests, such as science, social science, and foreign languages. In university, on the other hand, students are usually required to take an English language unit in the first and second semesters.

The delivery of English as a subject at the school and tertiary level shows some differences. In terms of time allocated for learning English, students at the school level majoring in programs other than language (e.g. sciences) normally need four hours a week to attend English language lessons, whilst those at the university level learn the language as a compulsory unit in two or more hours a week. Yet, high school students majoring in language programs (e.g. English language) normally need more than four hours a week to learn English. This also applies to university students majoring in English Education programs. These students have more hours for English tuition than students from other majors because they learn the language intensively. These students learn a variety of subjects or coursework units associated with English language and pedagogy, such as Speaking, Listening, Reading, Writing, Grammar, English for Young Learners, and Teaching English as a Foreign Language.

Today, high school graduates have two options for university entry with regard to choosing an English major program. The first option is to enrol into English Education programs, which aim to provide the students with the skills necessary for a teaching career at school level (Zein, 2014). In these programs, the students need to take a variety of coursework units that help them improve their language as well as pedagogy skills. In addition, this program also equips the students with skills other than these two skills, such as translating and doing business related to the uses of English. Despite all these additional coursework units, the main objective of this course is to produce English language teachers at the secondary school level in

Indonesia. The second option caters for students who want to learn English literature (Zein, 2014). Some examples of units in this program are Poetry, Prose, Drama, and Introduction to Literature. Students in this program also learn the four language skills and other units, such as morphology and semantics. In these two programs, all the students are required to write a bachelor thesis for the completion of their degree.

In terms of the curriculum, ELT in Indonesia has undergone some changes. Lie (2007) reported that Indonesia has implemented different types of ELT approaches into the classroom. For instance, in 1994, the meaning-based curriculum was used. This curriculum was also perceived as being communicative, meaning that the use of it would help Indonesian learners of English develop their communication skills, particularly in speaking. Ten years later, in 2004, a competency-based curriculum was introduced by the government and rolled out to all schools in the country. This curriculum was seen as promoting communicative language skills. Despite the fact that many Indonesian school teachers are not proficient users of the language, fostering students' ability in communicative aspects through curriculum alteration remains imperative for the government.

With regards to its role in multilingual communities, where people speak different languages, and professional development, the teaching of English in Indonesia, however, needs continuous evaluation. Kirkpatrick (2007) suggests at least two points in this respect: re-designing the content of the English curriculum and redefining the goals of learning English. Kirkpatrick believes that because of the growing use of English among people from multilingual communities, the English curriculum needs to accommodate the needs of its users, for example, in understanding and expressing the cultural values of each user. With this in mind, Kirkpatrick (2007) asserts that the teaching of English may need to be focused on empowering English language learners to be able to communicate successfully with people from diverse communities. This can help Indonesian learners of English be prepared for engaging effectively in English language uses within such multilingual communities.

Whilst developing learners' intercultural literacy and identity has become increasingly relevant to today's language classroom practices (Mercieca, 2014),

fostering learners' language skills through various classroom activities also remains important. In the context of English language teacher education programs, for instance, to support lecturers' endeavour in engaging pre-service teachers in communicative classroom activities, Dobinson (2012) suggests that lecturers need to regularly examine current developments in educational research so that they can critically respond to and contribute positively to addressing the multiple issues involved in teaching English. In the long run, this may help English language teacher programs to develop rapidly in many aspects, such as curriculum, teaching resources and lecturers.

The growth of English Education programs, also known as English language teacher education programs, is due to the increased status and uses of English in many parts of the world. Burns and Richards (2009) commented on the proliferation of the programs saying that an initiative to engage in worldwide social and economic advancement has driven many countries to develop English language teacher education institutions. In the past, the focus of the programs was on the development of specific knowledge and skills, whereas today's focus is on extended and continuous support and professional development of the teachers (Freeman, 2009), as well as pre-service teachers. Central to this enterprise is the issue of how such programs can adequately prepare English language teachers for their future teaching careers individually and socially, as well as what ongoing support they can offer teachers beyond graduation.

1.2.3 English Language Teacher Education (ELTE)

ELTE in Indonesia serves as an institution that caters to high school graduates who are interested in teaching English at the school level. It cultivates students' skills in using the English language as well as having pedagogic goals. Upon the completion of this education program, graduates should be able to demonstrate the required skills for teaching general English (all the language skills taught in one subject, English). Zein (2014, p.3) asserts that these graduates "will have acquired English language proficiency knowledge and knowledge and skills related to curriculum, syllabus, language testing and assessment, teaching methodologies, teaching skills, and materials development". Yet, if their goal is not to become English language

teachers, these graduates can still find jobs in other employment sectors when they graduate, such as working for the government and private businesses.

In Indonesia, there are a lot of universities that offer the ELTE program. Twelve state universities run this program, and others are run by private universities, which have gained a good reputation in administering the programs. In the past, these state universities were the Institutes of Teaching and Education Sciences, which offered programs for educating candidates of teachers. All the universities offering teacher education programs are called The Institution of Education and Teacher Education or *LPTK (Lembaga Pendidikan Tenaga Kependidikan)* (Zein, 2014). The programs they provide cover all subjects that are taught in schools, such as English, Mathematics, Biology, Arts and Sports education. Each of these programs requires approximately four years to complete. Saukah (2009) reported that graduating student teachers majoring in the Department of English Education, for example, are conferred with a Bachelor of Education in English Language. These graduating student teachers are eligible to teach at the secondary level from Year 1 to Year 12.

1.2.4 Department of English Education

The Department of English Education (DEE), where the present study was undertaken, offers an undergraduate degree program in the Faculty of Letters and Culture, *Universitas Negeri Gorontalo* (UNG). In the book titled *Fakultas Sastra dan Budaya: An Academic Guide Book*, it is stated that UNG is a state university located in the Province of Gorontalo, which specialises in educating pre-service and in-service teachers, as well as non-teachers or professionals (*Universitas Negeri Gorontalo*, 2011). In addition to this specialty, the DEE also caters to high school graduates who wish to pursue a career as a translator or business person or tourism-related practitioner. The duration for completion of this program is four years, divided into eight semesters (*Universitas Negeri Gorontalo*, 2011). Students majoring in this program are required to do 145 credits for the completion of their study, and this includes undergraduate thesis writing. Enrolment into this program takes place annually through three different types of entrance tests, namely, *Seleksi Nasional Masuk Perguruan Tinggi Negeri* (the National Selection Test for State University Entrance), *Seleksi Bersama Masuk Perguruan Tinggi Negeri* (the Joint

Selection Test for State University Entrance), and *Seleksi Mandiri Universitas Negeri Gorontalo* (the *Universitas Negeri Gorontalo* Entrance Test).

The DEE has around 52 teaching staff, many of whom completed their master's and doctoral degrees with overseas universities (*Universitas Negeri Gorontalo*, 2011). These staff teach a particular coursework unit in a teaching team, which usually consists of two to four staff. The team designs their own syllabus, and schedule teaching sessions (or teaching weeks) based on the number of classes they have. For instance, if they are assigned to teach TEFL (Teaching English as a Foreign Language) to five classes, all the team members need to share an equal number of teaching sessions. One handles the first eight sessions, and the other handles the remaining eight sessions. Of all these teaching team members, there is usually one person who is in charge of leading the rest of the team while, for example, discussing syllabus design.

The students are high school graduates, who come from the schools in the Province of Gorontalo, and the surrounding cities and provinces. They can all speak Bahasa Indonesia to communicate with one another, and different local languages. Some of the students show a better command of spoken and written English than others. The reasons for this gap in English proficiency might vary, but it can be assumed that the level of exposure to the language uses during their study plays a key role in determining the success of their language learning outcomes. As Lie (2007) reported, the differences in English language proficiency level among Indonesian school students might be caused by the amount of time they spend on seeking the opportunities to practise using the language in their everyday lives. Upon the acceptance of their enrolment into the DEE and following the result of the placement test, the students are grouped into certain classes that consist of a number of students (between 20-35 students) from the same year of enrolment. The more students enrol, the more classes that the DEE open for a certain period of university entrance test.

1.2.5 The Faculty of Letters and Culture

The Faculty of Letters and Culture, where the DEE is positioned, is one of the faculties in the *Universitas Negeri Gorontalo* or the State University of Gorontalo,

Indonesia. It aims to foster teaching, research and social community services, as well as educate pre-service and in-service teachers, in particular, for future employment in language, literature, and art related sectors (*Universitas Negeri Gorontalo*, 2011). Specifically, this faculty seeks to achieve the following objectives, as stipulated in the *Academic Guide Book of Faculty of Letters and Cultures, Universitas Negeri Gorontalo* (*Universitas Negeri Gorontalo*, 2011). These objectives have been translated into English.

1. To help students to become skilful as academics or professionals in the language, literature, art, culture, and tourism-related sector of employment that highlights technology advancement.
2. To conduct technology-based research that gives benefits for the society in the fields of language, literature, art, culture and tourism, as well as teacher education.
3. To foster students' various skills related to the sector of employment and to strengthen the links that can develop the competitiveness level of the faculty.
4. To develop students' entrepreneurship skills and to support their various academic and non-academic-related activities.

The Faculty of Letters and Culture has four departments that administer undergraduate programs and one Diploma program. The departments are the Department of English Education, the Department of Indonesian Education, the Department of Art Education, and the Department of Tourism. The faculty develops the teaching syllabuses based on the Law Number 20 Year 2003 and the Government Regulation Number 19 Year 2005, as well as the recommendations generated from the curriculum workshop at the faculty and university level. In this faculty, the teaching practices are weighted 40 percent for lecturers and 60 percent for non-lectures (e.g. workshop and laboratory-based activities). The teaching approaches applied by the lecturers are informed by discovery, collaborative and cooperative learning (*Universitas Negeri Gorontalo*, 2011).

1.2.6 English teaching in the Faculty of Letters and Culture

English is taught across the departments in the Faculty of Letters and Culture in the *Universitas Negeri Gorontalo*. As a compulsory coursework unit called English Language, English is taught in semester one in the Department of Indonesian Education and Department of Arts, and in semester one and two in the Department of Tourism (Diploma Program) (*Universitas Negeri Gorontalo*, 2011). In the Department of Tourism, the students also learn English as a compulsory unit called English for Profession in semester three, four and six (*Universitas Negeri Gorontalo*, 2011). Unlike the English Language unit, that is weighted two credits, English for Profession 1 and English for Profession 2 are allocated 3 credits, whereas English for Profession 3 has the same amount of credits as the English Language unit taught in the other two departments (*Universitas Negeri Gorontalo*, 2011). In the Department of English Education, the teaching of English is represented in a variety of coursework units, such as Speaking, Reading, Listening, Writing, Structure, English Morphology, English Syntax and Psycholinguistics (*Universitas Negeri Gorontalo*, 2011).

The lecturers who teach English Language and English for Profession units are from the Department of English Education. They are assigned by the Head of the Department of English Education to teach the units in teams, which usually consist of two to three lecturers with similar expertise. The syllabuses they design for each type of English-related units are informed by the curriculum of each of the departments. This means the lecturers develop the syllabuses to address the objectives and outcomes stipulated in the curriculum used by each of the departments. For instance, in the unit English for Profession in the Department of Tourism, the students learn some English expressions for wider purposes in tourism-related employment. They might develop their skills in using the language for tourist guides or business correspondence purposes.

1.3 Purpose of the study

The Department of English Education, the context of the present study, is an institution that is responsible for providing secondary schools with competent English teachers in Indonesia. ‘Competent’ means the graduate students meet certain

criteria with respect to language and pedagogical skills before they teach English as an additional language to Indonesian school students. To help them become competent, it is necessary to ensure sustainable improved ELT practices in the institution, which in turn helps maintain highly qualified graduate students who will bring continued improvement in English language teaching at secondary schools in Indonesia.

The improvement of ELT in the Department of English Education has taken place in many ways. The curriculum has been revised, the lecturers have been continuously encouraged to develop their professionalism, and the teaching resources have been improved. However, challenges persist, especially in the area of developing English learners' oral communication skills, leaving lecturers with more tasks to accomplish. I have noticed some examples of the challenges while working in the department as one of the lecturers, such as lecturers having difficulties in creating opportunities for pre-service teachers (PSTs) to engage in effective L2 oral interaction due to limited teaching hours. Another example is PSTs having difficulties in getting adequate stimuli for L2 oral interactions in and out of classrooms because of L1 use outweighing L2 in some ways. Even though examining the lecturers' perspectives may not help address all the different challenges in oral communication domains, such examination can provide meaningful insights that lecturers can then use to empower their PSTs with the skills to boost their oral language learning.

The primary purpose of the study is to investigate Indonesian English lecturers' perspectives on the teaching of OCS in the context of English Education program in Indonesia. It seeks to find out whether or not participants' perspectives on the teaching of certain types of OCS are useful for, or relevant to, not only the students' language learning, but also to the current curriculum of ELT at the secondary school level in Indonesia. This study also explores the lecturers' objectives in teaching English oral communication, their understandings of the types of communication challenges that their PSTs experience, the strategies used to deal with these challenges, and whether or not teaching OCS is part of their pedagogical practice.

1.4 Research design

The present study employs a case study approach (Yin, 1984) in order to provide a more holistic and comprehensive view of how Indonesian English lecturers view the teaching of OCS in relation to preparing pre-service teachers to teach English at the primary and secondary level in Indonesia, and whether or not pre-service teachers are encouraged to use OCS on the course. Data were gathered from all English language lecturers (n=11) who were teaching Speaking and Listening at the English Education program in a university in Indonesia using a semi-structured interview protocol technique. This technique was supplemented by observing the lecturers' lessons and analysing the teaching syllabuses that they were using. Data from lecturers were corroborated with that of the participating PSTs majoring in English Education program.

Data about the lecturers' perspectives on teaching OCS were identified by exploring their responses about their goals in teaching oral communication, what oral communication challenges that they think PSTs might have, how they deal with the challenges, and whether or not they encourage PSTs to use OCS on the course. In order to analyse the data, a thematic analysis approach was used. To ensure its trustworthiness, all the participants were invited to cross-check the interview transcripts and the codes that had been developed.

1.4.1 Research questions

The key research question of this study was: What are the perspectives of lecturers on English oral communication strategy instruction in the English Education Program in a university in Indonesia?

Four guiding questions are detailed below.

1. What are lecturers' objectives in teaching English oral communication?
2. What are lecturers' perspectives of pre-service teachers' English oral communication challenges?
3. How do lecturers cope with these challenges?
4. Do lecturers encourage pre-service teachers to use English oral communication strategies in and out of classes?

1.4.2 Scope of study

The scope of the present study is limited in a number of ways. First of all, the study was not primarily designed to investigate which type of OCS that lecturers reported to use in the classroom, or what functions each strategy has, but rather it sought to uncover lecturers' perspectives about OCS instructions. Second, it did not address in detail any individual differences, such as age and level of proficiency, which contributed to the type of challenges and ways to deal with them in light of teaching oral communication classes. Third, the study considered the voices of the student teachers about OCS instruction as evidence, which helped verify the lecturers' responses to the research questions.

1.5 Significance of the study

The main significance of the study is that it contributes to an understanding of how Indonesian English lecturers perceive the relevance of teaching OCS as an aid to the development of the oral proficiency level of English language pre-service teachers in Indonesia. A number of studies related to the present study have been undertaken in the past, but the focus of this earlier work was based on classifying the strategies and how the strategies can be introduced into the language classrooms (e.g. Dörnyei, 1995; Rohani, 2012; Tarone, 1981; Willems, 1987), identifying the effect of the strategy use (e.g. Jamshidnejad, 2011; Omar, Embi, and Yunus, 2012), and describing the use of the strategies and the reasons for using specific type of the strategies (e.g. Azian, Abdul Raof, Ismail, and Hamzah, 2013; Todd, 2005).

Arguably, there remains a need to better understand whether or not teaching the strategies is important to Indonesian English lecturers in their efforts to improve the level of English oral proficiency of their PSTs. This present study differs from earlier works to the extent that it provides evidence of how Indonesian English lecturers perceive the need to teach OCS by looking at what objectives they have in teaching English oral communication, what English oral communication challenges they perceived as being experienced by PSTs, how they deal with the challenges, and whether or not they encourage PSTs to use OCS on the course. Thus, the findings of this study are expected to fill a gap in the established body of OCS literature, which so far has given limited attention to the investigation of Indonesian English lecturers'

perspectives and practices regarding OCS instruction, particularly in the Indonesian context.

Another significance of this present study is that it addresses lecturers' awareness of the OCS instruction, if this instruction is seen as useful and relevant to the curriculum, and whether it is manifested in the lecturers' classrooms experiences. This is important as such instruction may assist PSTs to cope with different types of communicative activities that they have to perform during their studies in the English Education program. With this in mind, the study might provide a rich insight into how the lecturers encourage their PSTs to deal with their limited English linguistic resources.

Finally, the present study may inform the design of ELT syllabuses used in the Indonesian context. The development of the syllabus needs to focus on the extension of language exposure. Our language learners can benefit from the use of syllabuses which allow considerable opportunities for them to practise using the language they are learning (Brumfit, 1981). Brumfit (1981) adds that it should allow them to do many things that may not be entirely predictable, while at the same time, it equips them with certain strategies that can help them to learn how to survive a target language communication.

1.6 Conceptual framework

The conceptual framework of this study is presented in the form of a diagram, as shown in Figure 1 below. OCS instruction, as the central theme of the study is located in the middle of the diagram. This theme is linked to a number of relevant concepts by arrows. These concepts are grouped into four main areas of research: context, lecturer, underpinning conceptual areas, and the perspectives of Indonesian English lecturers. There are three sub-groups in this framework, namely ELT in Indonesia, language learning and English use in the world. The ELT in Indonesia sub-group consists of English language teacher education programs and curriculum. The language-learning sub-group covers objectives, challenges and learning strategies.

In the lecturer research area, three sub-groups are presented, namely, pedagogy, knowledge, and profile. The pedagogy subgroup includes teaching objectives and practises; the knowledge consists of OCS (types and functions), oral communication challenges and strategies to handle the challenges, and the profile comprises of years of teaching and proficiency level. The underpinning conceptual areas include teaching approaches, sociocultural theory, critical language pedagogy, World Englishes, psycholinguistics, and language teacher cognition.

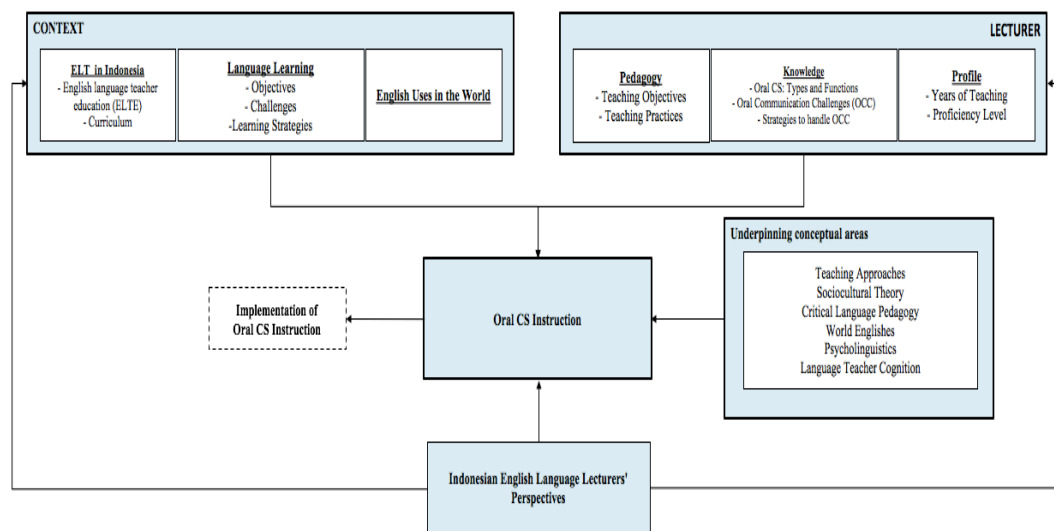

Figure 1 Conceptual framework

The two areas of research, context and lecturer, helped inform the analysis of the data. It was important to take into account the curriculum being used in ELT in Indonesia to find out whether or not certain types of OCS instruction are included, or whether learners are encouraged to take risks to solve the communication problems they experience when communicating orally in English. Accordingly, teaching objectives in oral communication classes were also considered as relevant for the analysis because they can provide rich background information about the description of skills that Indonesian English learners need to master in their English learning, as well as situations or functions associated with the uses of English in the learners' future careers. This present study, however, did not examine how certain types of OCS instruction operate in the classroom. That is why the "implementation of OCS instruction" is put within dotted brackets in the diagram.

1.7 Organisation of the thesis

This thesis consists of six chapters. Following this chapter, Chapter Two reviews the existing literature and research that motivates and generates the research questions addressed in the thesis. It reviews some major findings from empirical research about the issues and challenges related to the teaching of English in different contexts. It focuses on the relevant areas in language teaching and learning, including sociocultural theory, critical language pedagogy, World Englishes, psycholinguistics, and language teacher cognition. In addition, Chapter Two also considers some approaches to language teaching, and strategies in language learning.

Chapter Three describes the research design used in the study. Key findings from an analysis of the research data are presented in Chapter Four. This includes findings that address the four guiding questions. Chapter Five provides a detailed discussion and interpretation of the findings of the study, with references back to the research questions and the literature review. Finally, Chapter Six concludes the thesis by summarising the study's findings and outlining the pedagogical and research implications of the study, as well as offering recommendations for consideration.

1.8 Summary

This chapter has described the background and context to the study, as well as the purpose of the study. It has also outlined the research design, the significance of the study, and the conceptual framework. The last section of this chapter has presented the organisation of the thesis.

This chapter introduces a number of concepts pertaining to the uses of English in the world, the nature of L2 oral communication, oral communication strategies as well as language learning strategies. In addition, it reviews some conceptual areas relevant to this present study, such as sociocultural theory, critical language pedagogy, World Englishes, psycholinguistics and language teacher cognition. Several teaching approaches commonly used in the ELT classroom are also reviewed. This chapter ends with a summary.

2.1 English in the world

English is a language spoken by a great number of people around the world. According to Canagarajah (2007), the people who speak this language now include speakers of other languages, who learn or acquire English for various reasons, such as migrating to English-speaking countries or undertaking education in one of these countries. This gives English a perceived status as a global language, which denotes that people from different cultural backgrounds across the world can connect easily for various purposes (Crystal, 2003). English is used as a medium of instruction in a large number of universities around the world and is one of the official languages of the United Nations and other key international bodies, such as the Association of Southeast Asian Nations (ASEAN). The increasing number of people who are now using English as an additional language contributes positively to the spread of English and the functions it plays in a wide array of global situations.

In Asia, the role of English is significant. The ten members of the ASEAN: Indonesia, Malaysia, the Philippines, Singapore, Thailand, Brunei, Vietnam, Laos, Burma, and Cambodia, use English for official communication in ASEAN diplomacy. Although some other languages were once proposed as alternative working languages among the ASEAN members (French and Malay), these two languages have never replaced English (Kirkpatrick, 2008). English remains the preferred language of ASEAN, even taking Chinese into account. Being proficient in English as a global language would help countries connect to one another and strengthen the connection for a mutual relationship in various walks of life.

English plays a major role in education, especially in higher education, with many international students from non-English speaking countries studying in English speaking countries (Crystal, 2003). To get this opportunity, the students must be able to demonstrate a good command of English, which is generally proven by an English proficiency test, such as IELTS and TOEFL. This situation has had a massive impact both on the receiving universities and the home countries of the students. The universities invest in providing language assistance for international students through English language centres where students attend a specific program to help them improve their proficiency in English before university study. In the home countries of the students, the numbers of English training institutions have grown rapidly in order to respond to English learning needs, and institutions also provide consultation services for overseas education-related purposes. There has been a great increase in the publication of books written for the students to learn English (Pennycook, 2014).

In entertainment, English use is apparent in the production of movies, TV shows, or songs which highlight English (Crystal, 2003). The target consumers are not only the people who speak the language as their L1, but also those who speak English as an L2 or an additional language. BBC World and CNN are examples of English news broadcasters with millions of viewers around the world. In fact, as Crystal (2003, p. 98) put it, “channels with a religious orientation also often broadcast widely in English: for example, World Orientation Broadcasters transmit to Europe, the Middle East, and North Africa”. It is not just the language use that is attractive to consumers; the presentation of the entertainment is also interesting for the consumers to enjoy. Ideally, to be able to have access to all these productions and to make the most of them, one would need to understand the language that is used in the production. Hence, learning the language is imperative and relevant. This contributes to the proliferation of English-related business throughout the world, and leaves the language with a special status as one of the most needed languages in the world.

In the economic domain, English is indispensable. Business trade transactions are carried out in English, both in oral and written form (Crystal, 2003). Interaction involving traders happens not only in face-to-face modes, but also through online modes. Today’s technology development has made this sort of interaction possible; thus, it enables people from many parts of the world to network with one another for

different purposes online. This does not only involve traders from countries where English is the primary means of communication between the people, but also from other countries where languages other than English are used. To be able to take part in this worldwide business, by and large, traders need to be able to speak English as a lingua franca and connect with people from other linguistic backgrounds. Despite the increasing uses of other languages, such as Chinese and Japanese, for these functions, the use of English remains important (Crystal, 2003).

The spread of English worldwide has grown rapidly, from small-scale aspects, such as signs at airports, to larger ones, for instance, bilateral meetings (Crystal, 2003). However, this rapid spread of English also poses certain challenges, one of which is related to the local culture of the speakers who adopt the language. In the Indonesian context, Lauder (2008, p. 13) stated, “some educators in Indonesia have long worried that the widespread knowledge of English would have a negative impact on Indonesian culture, values and behaviour”. Western “liberal values” might influence Indonesian’s sense of nationalism. Moreover, an overuse of English in the wider domain of Indonesian language uses, such as education, business and governance, corrupt the use of standard Indonesian and local languages which constitute the country’s cultural heritage.

Preserving appropriate uses of the Indonesian language in many aspects of life in the country is crucial. One of the major reasons is that this language unifies Indonesians from various linguistic backgrounds, and gives them an identity as being Indonesians. Indonesia is “the fourth largest nation in the world”, with hundreds of regional languages spoken by the people (Gordon, 2005, as cited in Lamb and Coleman, 2008, p. 189). Lie (2007, p. 2) adds that in this country, there are approximately “669 distinct languages spread over 3000 inhabited islands”. The linguistic richness of Indonesian can be seen from the uses of the Indonesian language and the regional languages in the Indonesians’ everyday life. While preserving the local languages is important as stipulated in the Law of the Republic of Indonesia Number 24 Year 2009 on Flag, Language, Symbol, and the National Anthem, the promotion of the Indonesian language among the people also remains a central concern.

Issues about the impact of English on other languages have been extensively discussed in many studies. Crystal (2003, p. 21) recognises that English spread has currently stimulated “a stronger response in support of a local language”, and states that in some parts of the world, English spread has slowed down the uses of the local languages, such as in the case of Australia and North America. Local languages may disappear at the expense of the compulsory use of English. This is described by Kirkpatrick (2007), who gives an example of how multilingual speakers in Britain may lose their first languages because of the demand to master English as a major requirement to gain entry to employment. In fact, Kirkpatrick (2007) maintains, non-English speaking countries that administer English tuition should be aware of the cost needed to carry out such tuition. As he puts it, “how much are parents willing or being asked, to pay in order to ensure that their children learn this apparent passport to social and economic improvement?” (Kirkpatrick, 2007, p. 182).

Another challenge associated with the spread of English relates to defining the English language spoken by its speakers in the world. Kachru (1990) has proposed the terms Inner, Outer and Expanding Circles to define speakers of the language who come from various linguistic backgrounds. According to Kachru, the Inner Circles are speakers of English as a first language, such as Australians and British; the Outer Circles are those who use English as a second language, such as Indians and Singaporeans; and the Expanding Circle refers to people who use English in the context of English as a foreign language, such as in Indonesia. However, this proposal has been challenged by many scholars. Seidhofer (2005) argues that many terms are now used as alternatives to Kachru’s Concentric Circles, such as English as a Global Language (Crystal, 2003), English as a Lingua Franca (Jenkins, 2003) and World Englishes (Kirkpatrick, 2007). Rather than focusing on countries of residence as the basis for the categorisation of English language speakers, these writers focus on the goal in using English for communication in order to categorise speakers of the language.

There have been debates over what terms should be used. Rajagopalan (2012, p. 374) asserts, each of these terms “often carries with it associations and implications that have major consequences for the way we approach the very phenomenon”. English may be used as a lingua franca among speakers who do not share the same first

language (Kirkpatrick, 2007; McArthur, 2003). Yet, what also remains crucial is the fact that the English language that people speak today differs linguistically and socio-culturally. There are now different varieties of English, and the term World Englishes might best apply to define this phenomenon, especially from the perspectives of using the language for communication purposes. Kirkpatrick (2007, p. 3) realises these varieties, and states, “by World Englishes I mean those indigenous, nativised varieties that have developed around the world and that reflect the cultural and pragmatic norms of their speakers”. This suggests that the English language people use nowadays can no longer be associated as the language of the British, Australians, or Americans. This language has transformed itself into different ‘forms’ and is unique in its own context of uses.

All in all, the roles that English now plays in many aspects of life in the world have impacted on learners of the language, especially in the area of oral communication skills. One of the impacts lies in the challenges that the learners might face during their learning, whilst other challenges may be related to how English language teachers meet their teaching objectives and address the learners’ learning goals. In the following section, these impacts are further described.

2.2 Teaching English in an international context: objectives, challenges, and responses

For the present study, oral communication can be defined as a skill that involves speaking and listening. Oliver and Philp (2014, p. 5) describe oral communication as “the type of speaking and listening that occurs in real time (i.e. in the present) in communicative exchanges (i.e. interactions)”. This skill is one of the most crucial aspects in language learning because it demands that teachers pay full attention to not only output, but also to the quality of comprehensible input (González Humanéz & Arias, 2009). In language learning, oral communication often receives more attention from language learners and improved oral communication skills are widely accepted as a sign of successful language learning. Learners who manage to become fluent in speaking, for example, are often seen as proficient learners.

Undoubtedly, fluency in oral communication is achievable. However, there are various factors that can impede learners from achieving a high level of language proficiency. Studies have shown that, when expressing themselves in the language they learn, language learners often experience difficulties. For example, in Japan, silence was perceived as one of the major difficulties for Japanese students in English medium instruction classes (Nakane, 2005). In Indonesia, some examples of speaking problems of the students majoring in English Education include learning the appropriate use of intonation, prepositions, new vocabulary, and conversation maintenance (Mukminatien, 1999, as cited in Widiati and Cahyono, 2006).

For many language learners, to continuously engage in L2 conversation can be problematic because they often struggle with gaining time to think when communicating (Lewis, 2011). When communicating in L1, and they are aware that there are problems, language learners may cope with these problems relatively easy (Clark, 1994). However, language learners may find themselves ending up with disfluencies, using lots of pauses, fillers and other hesitation devices to gain time to think (Clark, 1994). For EFL teachers, this situation can be challenging for themselves in realising their objectives in teaching the language. This is the topic of the following section.

2.2.1 Objectives in teaching English

English language teachers have various objectives in teaching English, but they may share one foremost objective, which is to help English language learners to use the language with ease for various communicative purposes, both in written and spoken discourse. Researchers in ELT have investigated various perspectives that are relevant to these objectives. In the area of speaking, for instance, Derwing and Munro (2005) explored how to best improve learners' knowledge about English accents, to identify several misconceptions, and to make recommendations about teaching pronunciation. They suggested that it is important for lecturers to ensure that their student teachers have opportunities to develop approaches to pronunciation teaching grounded in current research. Hinkel (2006) suggested that integrating tasks in teaching speaking enables learners to develop their cognitive demands of fluency,

accuracy, and linguistic complexity. The focus should be on assisting students to achieve intelligibility rather than accent modification.

In an Asian context, such as Thailand, the teaching of pronunciation to help improve students' speaking skills has also been a concern of Thai English teachers. Khamkhien (2010) elaborated on the practice of teaching English at the university level in Thailand and described how speaking is taught, learnt, and assessed. This researcher asserted that pronunciation, natural communication and communication breakdowns need to be carefully addressed in the speaking class in order to assist students in passing assessments. Khamkhien suggested that ELT in Thailand may need to focus on establishing meaningful communicative activities to help Thai students experience an authentic English learning environment.

In the area of listening, Renandya and Farrel (2011) described how extensive listening could be an option to help low proficiency EFL learners develop their listening skills. These researchers pointed out several reasons why listening comprehension becomes problematic, such as when speech is fast and variable, and requires real time processing. They argued that overemphasis on strategy training may have an adverse effect on learners, in that it may conflict with the allocated time for teaching. Thus, they suggested that learners should be given ample time to listen extensively to materials which are meaningful, understandable and in line with their interests. Renandya and Farrel (2011) and Waring (2008) suggested that learners of the English language need to find materials that suit their level of proficiency in order to benefit from listening activities. Learners should be able to understand the majority of the given information and recognise most of the vocabulary. Appropriate grammar is needed in the listening materials, and attention should be given to whether or not listening texts engage the learners.

Zhang (2007) emphasised the role of teachers in teaching listening, contending that teachers needed to understand carefully their multiple roles: as a guide, who helped learners during the learning process; as a diagnoser, who could identify learners' problems and found solutions; as a designer, who could select appropriate listening materials; and as a motivator, who could encourage learners to actively participate in

listening tasks and learn more listening skills. Teaching listening strategies should be carried out systematically, aiming for long-term strategy training.

Overall, learning to communicate in another language for most beginners can be a demanding task. Likewise, teaching English as a foreign language is a challenging task for many teachers. In the following section, several studies that look at the challenges in teaching English are presented.

2.2.2 Challenges in teaching English

Some previous studies have shown that learners of English in many English language classrooms across the world experience various challenges in their learning, both in the domain of oral communication and English in general. Alyan (2013), for example, studied the perspectives of 20 English major students and six lecturers on oral communication problems in a university in Palestine. The main oral communication problems that the students had were found in the areas of pronunciation, vocabulary, exposure to English uses, self-confidence, and L1 influence in using English. Likewise, another study that looked at the challenges in EFL practices in general in the Arab World (Fareh, 2010) revealed that some of the major challenges in teaching oral communication skills were the inadequate preparation of teachers, the learners' lack of motivation, the teacher-centred methods and the limited exposure to English uses.

Inadequate teacher education is also highlighted as a constraint experienced by many English language teachers in other studies conducted in other non-English speaking countries, especially in Asian countries (e.g. Bekleyen, 2009; Fennelly & Luxton, 2011). In the domain of English in general, Fennelly and Luxton (2011) examined the readiness of Japanese English teachers in teaching English at the elementary level and found that a large number of the teachers did not feel confident in teaching English because they thought that they did not possess adequate knowledge of English pedagogy. Also, the study found that many of the teachers reported that they did not have a solid understanding of the curriculum, and had little time to prepare classes with their teaching team.

In line with Fennelly and Luxton (2011), Bekleyen (2009) examined foreign language learning anxiety (FLLA) in English language teacher candidates in Turkey. Bekleyen found that the students demonstrated high levels of FLLA, which were caused by a number of factors, such as receiving limited exposure to adequate levels of listening during high school, and especially word and sentence recognition. This researcher suggested that the teacher candidates may need to be equipped with sufficient understanding of the consequences that could grow out of the FLLA, as well as some skills about how to detect types of FLLA.

The findings from these studies are also evident in some other studies conducted in the Indonesian context at various educational levels, particularly in the domain of teaching English. Zein (2014) examined the adequacy of pre-service teacher education in Indonesia and factors that contribute to its efficacy or lack thereof and found that the pre-service teacher education was inadequate in preparing student teachers to teach English at primary level. This inadequacy was attributed to several factors, namely, the lack of specificity of English departments, the lack of specificity of PGSD (Primary School Teacher Education), and the lack of quality of teacher educators. Zein suggested that a reformulation and restructure of the curriculum employed by the English department and the PGSD was necessary.

Another study by Yulia (2013) investigated the challenges that Indonesian English teachers at the secondary school level experienced in their teaching practices. Yulia found that the challenges the teachers encountered were related to the students' motivation to learn English (which was mainly about passing the national examination) and the language of instruction in the classroom (which was mostly conducted in Bahasa Indonesia and Javanese). Yulia suggested that the teachers needed to develop their pedagogical and language skills in order to encourage their students to learn English for wider purposes.

In addition to the challenges already described, a study by Kurihara and Samimy (2007) found that in-service language teachers, who continuously attended professional upgrading programs, also faced some challenges related to their language learning and teaching. The study also looked at the teaching beliefs and practices of eight Japanese English teachers after attending a teacher training

program in the USA. Findings showed that the teachers faced various challenges when applying the knowledge they had gained during the program, such as a different perception of what makes good learning, a need to help students to pass university entrance examinations, and a difficulty managing a large number of students in the classroom.

The challenges mentioned above vary from linguistic competence (limited vocabulary) to psychological issues (lack of confidence and insufficient exposure to English uses outside the classroom). A number of factors influence the challenges. These include teachers' competence, students' motivation, and teaching methodology. Both language teachers and their students were reported as experiencing obstacles in their language-related activities. The next section reviews studies aimed at facilitating improvement in language teaching and learning in English language classrooms.

2.2.3 Overcoming challenges in teaching English

There are a number of ways the challenges discussed in the previous section have been addressed. The first examples of how challenges are addressed in ELT classrooms across various level of education is the use of digital games. Wu, Chen, and Huang (2014), for instance, examined the relationship between the use of digital board games, communication ability and intrinsic motivation in the context of Taiwan and revealed that the majority of the students in the digital board games classroom reported that they enjoyed the learning and felt comfortable speaking English. These findings were echoed in a study done by Vardanjani (2014), who investigated the effect and outcomes of using language games on learning vocabularies in the context of Iranian EFL. Vardanjani found that there was an improvement in the vocabulary learning by the students in the experimental group, and that the use of language games in learning provided an enjoyable, engaging and encouraging atmosphere for the students.

In a similar vein, Liu and Chu (2010) sought to investigate the influence of ubiquitous games on Taiwanese English learners' learning achievement and motivation. Their study revealed that the use of games in the English language

classroom helped the students achieve better learning outcomes and increased the students' motivation to learn English. Students reported that they were satisfied with the ubiquitous games because the games allowed them to interact using English in a real life context.

It was also reported in the literature that, instead of using games, other ELT teachers chose the notion of 'scaffolding' to manage challenges in their classrooms. Huong's study (2007), for instance, looked at the role of peers and how practice or outcomes might vary according to a peer's level of ability in the context of ELT in Vietnam. The study found that the assisted group had a more systematic performance than the unassisted. The group, which was scaffolded by a more knowledgeable peer, enabled all the group members to take turns to speak in the target language, eliminating the use of L1, which was more obvious in the discussion amongst members of the unassisted group.

Scaffolding as a strategy for managing challenges in ELT classrooms was also addressed in a study by Kayi-Aydar (2013). This study examined how language learners sought, responded to, and directed scaffolding across various classroom interactions in the Southwestern United States. The study showed that in small group work, scaffolding did not work effectively because of the influence of power struggles amongst the students. Indeed, scaffolding occurred regularly in the student-teacher interaction during various classroom activities. This study suggested that teachers needed to find ways to help students support their peers and learn from scaffolded talk.

In addition to the use of digital games and scaffolding, research into ELT points out the advantages of using L1 in managing oral communication challenges in the ELT classroom. Sali (2014), for instance, investigated the use of L1 by three EFL Turkish teachers at a secondary school in Turkey and found that the teachers used their L1 for academic and managerial purposes, and for developing social interaction with their students. Sali's study also demonstrated that the teachers tended to believe that the use of L1 facilitated classroom interaction and students' comprehension. A study by Ghorbani (2011), on the other hand, provided an additional perspective on how L1 use impacted on English learning. Ghorbani examined the communicative features of

L1 use in classroom adult pair/group work in the context of Iran, and found that the use of L1 varied across the pairs/groups. The students in the pair/group work used L1 for genuine requests of information, while the teacher used it for pseudo requests of information. Ghorbani suggested that L1 could also be used to create humour as a tool to make a classroom atmosphere more enjoyable.

With regards to the use of oral communication strategies, it was found that the use of some of strategies assisted in carrying out English interaction. In the context of Malaysia, where English is used as a second language, Azian et al (2011) investigated the communication strategies that non-native speaker novice science teachers used in teaching Science in English. The researchers found that the teachers used various communication strategies, such as code-mixing, checking, self-repetition and repair, in order to demonstrate their roles as teachers, novice teachers, and English language learners. It was also found that there was a high congruence between the teachers' and students' perceptions on the meanings and uses of the communication strategies employed.

All these studies show evidence of ways used by teachers and students to communicate in English. Using L1, games, and scaffolding helped language learners learn the language in an enjoyable learning atmosphere. Accordingly, the use of L1 has been identified as part of OCS, the topic for the following section, and can serve two functions, i.e. enabling learners to improve their oral performance while communicating using an L2, and helping teachers in their classroom interaction where L2 is used as the main language of instruction.

2.3 Relevant conceptual areas to language teaching and learning

This section begins with exploring sociocultural theory, critical language pedagogy, World Englishes, and psycholinguistics. It concludes with a brief description of language teacher cognition and its relation to this present study.

2.3.1 Sociocultural theory

The inclusion of sociocultural theory (SCT) into this present study is grounded in the ideas developed by Vygotsky: the study of how humans think and behave entails the

understanding of their interaction as part of a history, culture and society (Swain, Kinnear, & Steinman, 2011). In second or foreign language learning research, SCT occupies a particular domain where language learners' learning experiences are seen as a result of the learners' interaction with the external world, not solely as their own thinking process. Culturally constructed materials or symbols as mediation influence the way the learners learn English cognitively and emotionally (Vygotsky, 1978, as cited in Swain, Kinnear, & Steinman, 2011). These symbols can represent guidance available from all learning resources, such as textbooks and computers, colleagues, teachers, etc. SCT views these symbols as ways that can be taken to develop learners' learning experience.

From a SCT point of view, language is seen as the central point of departure for mediation, a concept that plays a key role in SCT. In language learning situated in the classroom context, learners' attempts to learn a language are mediated by many aspects, some of which include the teachers and peers. Through the use of language as the mediator, learners interact with one another and with the teacher, regardless of the language being used (L1 or L2), resulting in the possibility of having increased learning. Donato (2000) suggests that teachers and learners' involvement in any collaborative-based classroom activity assists language learners in expressing and understanding meanings, which helps learners activate their inter-language system. Lantolf (1994, p. 419) posits, "what is at one point socially mediated mental processing evolves into self-mediated processing". This means learners generally further process what they have been initially exposed to in order to develop their own learning.

In language learning, the notion 'mediation', which is central to the theory of SCT, is transformed into the notion of 'scaffolding'. Scaffolding can take many forms, the most obvious one being utterances. SCT looks at the utterances of a teacher and learners in a language class as being more than linguistic input that simply needs to be made comprehensible (Donato, 2000). The utterances are seen as essentially social practices that assist to shape, construct, and influence learning within interactional and instructional contexts (Donato, 2000). Assistance can foster the development of language learning as long as it is provided efficiently, that is by helping the learners with what they are not already able to do, or by giving them

meaningful tasks to facilitate better performance (Ohta, 2000). This is in line with Krashen's input hypothesis, which suggests that language input should be just beyond the learners' current level of language proficiency.

Scaffolding can also be in the form of teachers arousing learners' awareness of cross-cultural issues. This may assist learners to avoid having cultural misunderstandings when, for example, communicating in a target language with a particular individual from a particular culture. For teachers, developing an awareness of cultural issues often helps them find ways to address the impacts of language anxiety that many English learners, especially from the Asian countries, experience in the classroom (Jones, 2004). As Qu (2010) puts it, the unawareness of cultural implications and the inappropriate situational use of the target language considerably influence the outcome of learning a language.

2.3.2 Critical language pedagogy

Before addressing the notion of critical language pedagogy, it is essential to review a working definition of critical education. Essentially, the notion critical education connects learning and teaching by focusing on learners' improvement in thinking critically about their own learning. This concept is influential to the journey of the students' lives, which in turn can shape changes in society in which the students engage. Through critical education, students have the opportunity to be the agent of social change, and "to envision a social order which support their full humanity" in order to gain social power (Shor, 1987, p. 48). The goal for such education is to empower students with the ability to criticise the relationships between exploitation and domination and education policy and practices (Apple, Au, & Gandin, 2009).

Critical education is much influenced by the writings of Paulo Freire, who emphasised the enabling of learners to develop skills that allow them to recognise relationships between their experiences and the context in which they are engaged socially. According to Freire (1998, p. 30), teaching is not simply a matter of transferring knowledge, but of creating "the possibility for the production or construction of knowledge". Freire maintained that critical education allows teachers and students to reflect on their own teaching and learning practices respectively as a

way for them to construct new knowledge. Freire (1998, p. 31) argued, “whoever teaches learns in the act of teaching, and whoever learns teaches in the act of learning”. Thus, an act of teaching should aim at enabling the reproduction of what has been thought not only by the students but also by the teachers, without which an act of teaching is not valid (Freire, 1998).

Central to the concept of critical education is “the liberatory classroom” (Shor, 1987, p. 119). By liberatory classroom, Shor means that because students have different needs or styles of learning, teachers need to ensure the classroom atmosphere can address such differences. Thus, Shor (1980, p. 119) maintains, classrooms should serve the following developmental services: “workshop, studio, skill and counselling center, consciousness-raising group, kiosk-news service, and library”. If classroom learning operates in the framework of the developmental service, students can have more opportunities to maximise their potential because they can find learning modes that suit their learning styles, as compared to a classroom that is dominated by certain types of learning modes. Teachers, on the other hand, can have more opportunities to facilitate dialogue between students and other students as well as teachers.

Critical language pedagogy, therefore, is related to bringing back the essence of language teaching and learning itself. Language pedagogy, according to Pennycook (1990), is not simply about teaching language as an object of learning, of which its components are broken down into separate aspects and taught in the classroom. Pennycook (1990, p. 304) argues that language has been “reduced to a system for transmitting messages rather than an ideational, signifying system that plays a central role in how we understand ourselves and the world”. Indeed, Pennycook (1990) suggests that in language education, a language teacher should not be “a classroom technician”, but “an autonomous intellectual” who can induce “a view of the social, cultural, political and historical context and implications of language teaching” in their pedagogical practices (Pennycook, 1990, p. 304). This argument implies a need to adjust existing language teaching perspectives in order to empower language teachers and learners with the ability to experience the underpinning philosophy of education and put it into practice.

The core of critical language pedagogy reflects post-method pedagogy (elaborated in the following sub-chapter) because they both take into account contextual factors that come into play with language teaching. Critical pedagogy accounts for the transformation of culture into the notion of a “productive system” (Pennycook, p. 309). Giroux (1988), as cited in Pennycook (1990, p. 309), defines culture as “the particular ways in which a social group lives out and makes sense of its ‘given’ circumstances and conditions of life”. Differences of lived experiences of language learners, therefore, shall be respected and deployed “both as a narrative for agency and as a reference for critique ... creating the democratic sense of respect for difference that is essential to any notion of equality in society” (Giroux, 1989, as cited in Pennycook, 1990, p. 310). To this end, empowering teachers to work as “intellectuals” who continuously explore learners’ lived experiences is imperative (Pennycook, 1990, p. 310). This might help EFL teachers, in particular, to design lessons that meet the needs of their learners and to teach effectively, enabling their learners to become competent users of the language the learners learn.

In the context of English language teaching, particularly in English Education programs, applying the concept of critical education is essential in preparing competent English language teachers and users. Today’s development of English language across the globe is dynamic with respect to the increasing number of English speakers, with their specific linguistic features and various purposes for its uses. This should force teachers of English to adapt and to think critically about recent developments of the English language and its uses among diverse speakers. In addition, drawing on critical language pedagogy, teachers may want to carefully approach the way they teach oral communication classes, where students learn to become effective users of English. As suggested by Pennycook (1990), these language learners need to be able to use the language they learn in order to communicate and to understand the world. Thus, teachers may take the initiative to vary activities in English language classrooms to cater to the different needs of their students. Effective ELT in the 21st century needs to be informed by an understanding of World Englishes, a concept that is further explored in the following section.

2.3.3 World Englishes

As mentioned earlier, World Englishes is a term used to describe the different English varieties used in many parts of the world, particularly in territories where the language has been impacted by contact with the existing local languages, such as in Malaysia, India and Nigeria. This contact happened mainly due to the introduction of English during the period of colonisation, such as in Singapore and Kenya (Canan Hänsel & Deuber, 2013). The spread of U.S. dominance in trade across the world has also disseminated not only English culture but also English language to the people in these countries, affecting the previously established English language varieties (Canan Hänsel & Deuber, 2013).

The study of World Englishes, according to Jenks and Lee (2016, p. 1), focuses on investigating “the linguistic agency of those living in outer circle and expanding circle regions and countries”. Kachru (1990, p. 5) introduced the concept of Inner, Outer and Expanding Circles and suggested that these Concentric Circles of English, instead of signalling and underestimating different English varieties, resemble “a unique cultural pluralism” and “a variety of speech fellowships” of the English language. Some examples of these English varieties in the Outer Circles are the Englishes of Singapore, India, and Kenya, as well as the Englishes in Japan, China, Thailand and Indonesia in the Expanding Circle. Each of these varieties has its own uniqueness in terms of, for example, lexical items and pronunciation, which are influenced by the regional/national languages.

The theory of Concentric Circles of English, however, has been challenged by other scholars. Modiano (2009), for instance, argues that the increasing number of English users who are multilingual outweighs that of monolingual speakers of English. Thus, English shall not be exclusively seen as the language represented as an Inner or Outer Circle language, but as a “universal language, one which has utility in a wide range of form” (Modiano, 2009, p. 208). This implies that the teaching of English language as a ‘universal language’ should aim for a goal that “strives to accommodate as many interlocutors across the Inner, Outer, and Expanding Circles as possible” (Modiano, 2009, p. 211). As an alternative term for these three Concentric Circles, Modiano (2009, p. 212) suggests the use of English as a lingua

franca, i.e. “a language which has considerable utility in multicultural settings, among people with differing linguistic profiles”. This term is in accordance with the concept of World Englishes, which recognises the existing variety of English across countries in the world.

There are many reasons why the study of World Englishes is useful to teachers of English. First, World Englishes offers a more flexible framework as it is postulated that English is a language of anyone who speaks it (Rajagopalan, 2004, as cited in Harmer, 2007). This challenges the perceived privileges attributed to speakers of a particular English variety, such as British English or American English. World Englishes suggests equal rights for English users as speakers of this language who learn and use the language to communicate in international and local contexts (Harmer, 2007). In Malaysia, for instance, Malaysian English is used for educational, political, and economics purposes in this multi-racial country (Rajadurai, 2004). Owing to its prestige, however, Rajadurai asserts, there is a growing sense of pride amongst the users of the localized variety, Malaysian English. This enables different speakers of English around the world to construct their own identity and accept linguistic differences that grow out from their English interaction.

Second, the notion of World Englishes suggests a shift in ELT practices, particularly in the area of developing oral proficiency of learners of English. Given that the learners potentially use English to interact with different English users from various linguistic backgrounds, English teachers may want to shift the focus of teaching the language from gaining native like competence to having the skills to be intelligible in the L2. In countries where English is taught at school (like Indonesia), most of the time the use of English is situated within the countries’ context in order to serve educational purposes, entertainment, and employment. In fact, in such contexts, English language interaction usually involves speakers of similar L1 backgrounds, who share certain identical linguistic characteristics (e.g. pronunciation and vocabulary) in English communication. However, this does not mean that reaching a native like competence level of English should be avoided, but rather that English teachers need to inform their students about English varieties in the world and legitimise the English that they speak. Sung (2014) asserts that what is important in

English communication in today's globalised world is to be open minded about and accept linguistic diversity.

Third, the study of World Englishes is particularly useful for non-English speaking countries, such as Indonesia. Local teachers need more opportunities to develop their pedagogical practices. This may include the need to develop teaching resources, such as textbooks and curriculum that satisfy the needs of the learners in both local and international contexts. With locally designed resources, the teachers can better model language use in the context of Indonesia, because it is this model to which students have been exposed to. This is what Kumaravadivelu (2001, p. 539) describes as the importance of "local exigencies" in ELT, which suggests that "to ignore local exigencies is to ignore lived experience". Kumaravadivelu (2001) suggests that promoting a deeper understanding and deployment of lived experiences involved in the ELT arena is imperative, and this may include the promotion of local teachers as the most responsible agents for fruitful ELT.

Promoting local teachers in EFL classrooms has some advantages. First, these teachers are examples of successful learners of English who can model some ways that lead their students to achieve successful English learning (Harmer, 2007; Kirkpatrick, 2007). They bring with them different learning strategies that may work well with their students because they learn in the same learning context where exposure to L2 use is generally only available in the classroom. The teachers may use their L1 Bahasa Indonesia and English as languages of instruction in tandem. Second, local teachers are better able to manage difficulties that they encountered during their learning and pass on management strategies to their students. Phillipson (1992) believes that monolingual teachers of English may not be better suited to facilitate language learning in the classroom than their counterparts, local teachers, who spent some time learning the language as adults.

A careful consideration of various factors is needed before it is claimed that bilingual or multilingual local teachers are more suitable to teach an additional language. Moussu and Lurda (2008) contend that there are at least two factors that need to be taken into account in this respect: context of learning and teaching. The former relates to the situation where English is taught, whether in second language settings,

where exposures to the language being taught is available outside the classroom, or foreign language settings, in which exposure is mainly available in the classroom (Moussu & Llurda, 2008). The latter, on the other hand, relates to where the teachers work, whether in primary, secondary, or tertiary levels of education (Moussu & Llurda, 2008). Moussu and Llurda (2008, p. 338) claim that level of education impacts on the teachers with regard to “how they conduct their professional activity, what recognition they obtain from it, and their ultimate status within the profession”.

2.3.4 Psycholinguistics

Psycholinguistics is the study of how people acquire, use, perceive and produce language. In acquiring a language, people experience a “psychological processes through which a human subject acquires and implements the system of a natural language” (Caron, 1992, p. 1). This psychological process treats “the language user as individual rather than a representative of a society” (Field, 2003, p. 2). Yet, as Field (2003, p.2) maintained, psycholinguistics considers “the strengths and limitation of mental apparatus” that are shared within a society as a determining factor in individual linguistic performance. This means that psycholinguistics seeks to identify the linguistic behaviour patterns shared by individuals within a certain society where single or multiple languages function as the means of communication amongst the individuals (Field, 2003). Psycholinguistics is an interdisciplinary field, in which researchers from different backgrounds, such as psychology, linguistics and language pathology, conduct studies.

Research in psycholinguistics covers six major areas: language processing, language storage and access, comprehension theory, language and the brain, language in exceptional circumstances, and first language acquisition (Field, 2003). The first area is concerned with what happens when people speak or listen and what phases they go through when they speak or listen. The second area is related to issues, such as how the human mind stores vocabulary and retrieves it for communication purposes. The third area discusses how humans make meaning from the information they receive. The fourth area, looks at the complex processes of neurological and muscular activities in relation to language production. The fifth area looks at issues, such as the occurrence of language impairment and the relationship between age differences

or brain damage and language. Finally, the sixth area seeks to examine how people acquire language. Second language acquisition is included as part of psycholinguistic research areas. This area is further discussed below as it is relevant to the purpose of the present study.

Language acquisition is related to two different terms: second language acquisition (SLA) and foreign language acquisition (FLA). Although they may not be contrasted because of the similar processes involved in each (e.g. acquiring any subsequent language), the context of the acquisition can be different. For example, in Indonesia, English is learnt as a foreign language because its primary purpose for the majority of Indonesians is for education, not for daily communication as compared to the context of learning English in other countries, such as Singapore, Australia, and many European countries.

Any subsequent acquired (or learnt) language is called second language acquisition (Larsen-Freeman & Long, 1991). There are various theories that discuss this acquisition, and one of them is Krashen's Monitor Theory which draws heavily on understanding written or spoken language (and may also be described as Krashen's Comprehensible Input), how this understanding is achieved, and what a learner feels when attempting to gain such understanding. The theory suggests that any input that is understandable contributes to the development of second language acquisition (Macaro, 2003). It also states that output a learner makes is constructed and underpinned by two separate knowledge systems, namely, an acquired and a learned system (Krashen, 1982). In the acquired system, a language learner uses knowledge that is obtained subconsciously, whereas in the learned system, certain knowledge generated from instruction is used (Krashen, 1982).

There are five hypotheses in Krashen's Monitor Theory. These are the input hypothesis, the acquisition-learning hypothesis, the monitor hypothesis, the natural order hypothesis, and the affective filter hypothesis. This present study, however, focuses on the input hypothesis and the affective filter hypothesis as they are the most pertinent to the present discussion, which looks at linguistic and psychological aspects that influence L2 learners' learning experience. The input hypothesis suggest that language learners may not develop their language acquisition process unless the

input they are exposed to is understandable and slightly more advanced than their current level of proficiency. Language teachers, when providing language input for students, should remember that they need to adjust input to the learners' comprehension level, not their production level (Macaro, 2003). To this end, Macaro (2003, p. 28) said, "the learner's knowledge of the context will fill in the missing bits and understand any new language items", which then results in the acquisition of the language.

Receiving comprehensible input impacts on the acquisition of the new language. For learners, the opportunity to gain comprehensible language input is often available through classroom instruction, and at this point, teachers play a key role in providing comprehensible language input for the learners. In a context where a learnt language is the language that people outside the classroom use everyday, the opportunity is even richer. The classroom, hence, becomes the primary source for language learning, whereas outside the classroom settings are the arenas where learnt language features are put into practice. As Polio and Duff (1994) assert, what influences learners' performances in the language they learn stems from what they do in formal instruction, because it is in the classroom that language learners often have access to input.

The affective filter hypothesis posits that certain emotions may interfere with language learners' attempts to process language input and become an impediment to learning. This hypothesis suggests that when, for instance, a learner's affective filter is high, it is unlikely that the learner can take advantage of the input that is available. Some examples of filters which can obstruct the amount of input that a learner can understand are anxiety, lack of confidence and boredom. In the classroom context, language teachers need to focus on keeping the level of affective filters as low as possible. With the help of teachers in creating a conducive and supportive learning atmosphere, the processing of comprehensible language input for learners can be managed.

The importance of comprehensible input and a low affective filter also applies to the context of learning English as a foreign language (EFL). EFL and English as a Second Language (ESL), ideally, are not to be contrasted because they talk about the

same concept, namely, learning another language to complement any existing language (Larsen-Freeman & Long, 1991). Yet, the context of the learning may not always be the same. Unlike ESL learners, EFL learners might not have the same amount of exposure to input outside the classroom because they may learn English in a country where the language spoken outside the classroom setting is not English. However, opportunities for comprehensible input remain open if teachers continuously ensure successful exposure to language input that is comprehensible. As the theory suggests, incomprehensible input may obstruct the development of language acquisition.

Despite the popularity of the comprehensible input hypothesis, some scholars have challenged it. One of the objections raised is related to the claim that comprehensible input allows for language acquisition. Macaro (2003) posits that learners need to do more than just understand input – they should be involved in input modification by, for example, asking for clarification from their teachers, noticing new language items before they process and store them, and using the items when communicating orally. This suggests that comprehensible input alone may not always be helpful in supporting learners' language acquisition processes. In the classroom context where language input is often facilitated by teachers, critiques about the advantages of such input persist.

With regard to fostering oral communication skill levels in a target language, several studies have shown that relying on classroom language input is often not enough (Lie, 2007; Musthafa, 2001; Yulia, 2013). Musthafa (2001) stated that this situation is influenced by many factors, some of which are related to the teachers, including their degree of confidence in using the language as the main language of instruction in the classroom. Baker and MacIntyre (2003) affirm that language learners who learn a language in a place where that language is not typically used as the medium of ordinary communication (such as the use of English in Indonesia) often struggle to search for stimulation in the target language. This lack of exposure to meaningful uses of English as well as the language model in the classroom can negatively affect English learners' experiences.

Such problematic exposure to language use may be one of the reasons why many Indonesian English language learners experience constant difficulties when communicating in English. Few classroom activities in Indonesia provide the students with opportunities for improving their oral language skills. Consequently, the students may become reticent and passive, or at worst, demotivated (Cheng, 2000). Lamb and Coleman (2008, p. 195) pointed out that, in a study they conducted in a number of schools in Riau Province in Indonesia, many English lessons taught at the schools were delivered using “a very traditional teaching methodology”, where the students simply listened and wrote down information prompted by their teachers.

What is more, English language classroom activities at these schools mainly involve test-taking practices (Lamb and Coleman, 2008). As a result, other activities that promote actual use of the language might be absent in the classroom (Musthafa, 2001). Ideally, if being able to use English in oral communication is the goal of learning English in Indonesian schools, providing an adequate amount of time along with an appropriate methodology to help develop language learners’ skills in speaking should be an objective.

2.3.5 Language teacher cognition

Language teacher cognition, along with teaching methodologies and resources, plays a key role in language teaching and learning. According to Borg (2003), teacher cognition refers to the interrelated cognitive aspects of pedagogy. These aspects include teachers’ knowledge, perspectives, and assumptions, which are not easily visible. Other factors, such as teachers’ experiences as learners and their professional preparation programs, influence these cognitive aspects (Borg, 2003). This means that what teachers know and believe influences their instructional practices and classroom behaviour (Bedir, 2010). One example of how knowledge and beliefs affect teachers’ teaching practices is when teachers are challenged by a lack of teaching resources or students’ reticence during group activities. Their responses to these challenges may be different.

Teacher cognition also portrays “fragmentary, superstitious, and often inaccurate opinions” (Leindhardt, 1990, p. 18). It entails self-reflections of both pre-service and

in-service teachers, and their ability to cope with teaching and learning atmosphere in the classroom (Kagan, 1990). Because of its complexity and importance in teachers' pedagogical praxis, understanding teacher cognition becomes essential. In language teaching, for instance, this means understanding various aspects, such as teachers' pedagogic and language competence, as well as teachers' awareness of learners' characteristics, needs, and learning styles. Yet, to understand teacher cognition by direct assessment may not be possible because of some underlying reasons, such as that teachers may not be fully aware of their own state of teacher cognition or be open to acknowledge, for example, divergent opinions and assumptions (Leindhardt, 1990). Kagan (1990) believes that one possible way to investigate teacher cognition is by doing it indirectly, such as through extended interviews.

The importance of examining teachers' cognition, such as their pedagogic perspectives, as a vehicle for educational improvement has been explored in a number of studies (Chen, Brown, Hattie & Millward, 2012; Sen & Sen, 2012). Chen et al. (2012) examined the nature of excellent teaching as perceived by the middle school teachers in one province of China and explored the relationship of those perceptions with their teaching practices. These researchers found that the teachers in their studies considered principles such as life-long learning development and learners' involvement as the components of an excellent teaching model.

Sen and Sen (2012) investigated the perspectives of English teachers in incorporating language-learning strategies into their lessons in a private university in Turkey. The researchers found that the majority of the teachers believed that teaching the strategies helped their students to become independent learners and to increase their motivation in learning a specific language skill. When these findings are implemented, they can be helpful not only for teachers and policy makers in designing and managing educational-related matters, but also for students for their academic improvement.

Unfortunately, studies that investigate English language lecturers' perspectives on OCS instruction remain scarce. Those who have studied OCS have focused mainly on classification of the strategies and introduction of the strategies into language classrooms (e.g. Dörnyei, 1995; Rohani, 2012; Tarone, 1981; Willems, 1987),

identification of the effect of the use of the strategies (e.g. Jamshidnejad, 2011; Omar, Embi & Yunus, 2012), and description of the use of the strategies and the reasons for using specific type of strategies (e.g. Azian, Abdul Raof, Ismail & Hamzah, 2013; Todd, 2005).

While the importance of having oral communication strategy skills has been extensively highlighted in numerous studies, the usefulness and the relevance of teaching such strategies in the context of English Education programs in Indonesia has gained little attention.

2.4 Approaches in language teaching

There are multiple approaches to language teaching. In this section, five of these approaches are presented, namely, communicative language teaching (CLT), task-based language teaching (TBLT), content and language integrated learning (CLIL), content based instruction (CBI), and post-method approaches. The first part of the section discusses CLT, followed by TBLT, two approaches that many ELT teachers in Asian countries, such as Indonesia, reported to use in their classroom (Littlewood, 2007). The second part presents CLIL, CBI, and post-method approaches, recent approaches in the ELT arena, which help provide insights into the shifts in understanding teaching communicatively in the 21 first century.

2.4.1 Communicative language teaching

Communicative language teaching or CLT is one of the most well-known approaches in the ELT arena. Among a number of English language teaching approaches, CLT is the one that is embraced by many English teachers in Asia and all over the world (Littlewood, 2007), particularly in Indonesia. In the 2004 English curriculum in Indonesia, for instance, this approach was adopted as an umbrella for English language teaching methodology in secondary schools (Lie, 2007); it aimed at developing students' communicative competence in four main areas: listening, reading, writing and speaking. Hymes (1972), who coined the term CLT, claimed that understanding a language involves more than understanding a set of grammatical, lexical, and phonological rules. In CLT-driven classroom pedagogy, language learners should be helped to develop other areas of ability, such as those

that can be found in sociolinguistic, discourse, and strategic competence, if teachers wish to see their students use the language effectively and appropriately.

Within CLT-based instruction classrooms, the development of communicative competencies is achievable. CLT offers a wide range of activities, such as storytelling and information gap filling, which promote meaning-focused communication (Harmer, 2007). Bax (2003) added that other activities within such classrooms, such as pair and group work, promote fluency and student-based interactions. These sorts of activities, according to Jones (2004, p. 37), can provide learners with an opportunity “to improve proficiency and break out of the vicious circle of language anxiety”. In fact, when learners are personally engaged in meaningful classroom activities, L2 acquisition can take place (Musthafa, 2001).

CLT application in English language classrooms needs to be carefully considered, however, when it is related to a context where the language is used as an additional language. Account needs to be taken of the way English language learners attempt to position themselves as users of a target language situated in a classroom context, confined by some variables, such as learning styles and learning goals. McKay (2003) pointed out that CLT often does not work well in many language classrooms in the Expanding Circles countries, such as Indonesia and China. Learning styles of the students are not the same as those in monolingual English speaking countries, where active participation in the classroom is highly encouraged and appreciated. There are also large numbers of students in every language classroom.

2.4.2 Task-based language teaching

TBLT is another commonly used English language teaching approach. It is considered to be a development of CLT (Littlewood, 2004; Nunan, 2004). The use of this approach strengthens some pedagogical principles and practices common to CLT, such as an emphasis on learning to communicate through interaction in the target language, the provision of opportunities for learners to focus on language and the learning process (Nunan, 2004). In fact, it links classroom language learning with language use outside the classroom (Nunan, 2004). Central to this linkage is the task, which is defined as various classroom activities that encourage learners to interact

using the language they are learning and which focus on expressing meaning (Nunan, 2006). The difference between an activity and a task is that tasks are “the real-world activities people think of when planning, conducting, or recalling their day” (Long, 2014, p. 6). Some examples of tasks in the TBLT-driven classroom may include ordering food by phone, buying groceries or visiting a doctor.

Tasks in TBLT classrooms also have some other characteristics. Ellis (2003) describes tasks as encouraging learners to bridge gaps in information by using certain sets of linguistic resources that the learners can choose. These gaps, according to Prabhu (1987) can include information gaps, reasoning gaps and opinion gaps. Accordingly, the outcomes that the learners expect to be able to make should not be something that are solely related to linguistic features, but non-linguistic features as well. The use of these kinds of tasks helps promote language acquisition because learners can choose which grammar constructs or lexical items they need to complete the tasks (Harmer, 2007). In fact, because the tasks are learner-centred, learners may find ways to maintain their learning passion as they are familiar with the kinds of tasks they have to deal with in the L2 context.

With the rapid development of TBLT in the ELT world, especially in Asian countries, TBLT has enjoyed recognition from teachers, lecturers, and researchers. Its application is not only present at the school level, but also in tertiary institutions, particularly in English language teacher education programs. Yet, how and when to use TBLT to teach English has been largely debated. Sato (2010), for instance, claimed that TBLT may not be a suitable approach for teachers to teach a pre-specified language structure or grammar. This has implications for countries like Indonesia, where English tests for Indonesian learners of English often consist of grammar or structure tests. As Sato (2010) posited, TBLT is not designed to assist students in these types of examinations. This approach might be suitable for assisting students to communicate, but assessment of successful performance in the target language cannot be done using paper-based tests. In other words, when TBLT as the sole approach to language teaching is chosen, there are some consequences that national language planners need to face.

Nevertheless, the use of TBLT in English language classrooms has so far been successful in helping teachers to develop learners' communicative competence. However, few researchers have undertaken studies about TBLT and their relationship with OCS instruction in different discourses. In one example, Omar, Embi, and Yunus (2012) researched the use of OCS by 28 undergraduate students taking a communication course in a university in Malaysia in an information-sharing task via Facebook groups. These researchers found that one of the most common strategies that the learners used was literal translation, followed by approximation and code switching. Another example is a study by Rohani (2011) in which 23 university students' learning strategies in a TBLT-based classroom in Indonesia were examined. The findings showed that the implementation of TBLT influenced the students' shift in using learning strategies. Rohani (2011) found that the students increased their use of strategies, especially those for coping with speaking problems, and those students with higher proficiency level used more varied strategies throughout one semester.

2.4.3 Content and language integrated learning and content-based instruction

Although these two approaches are not yet in popular in use in Indonesia, referring to them can provide meaningful insights into the practice of ELT across countries in the world. As such, relevant principles of the approaches that might help ELT teachers in Indonesia develop their teaching practices can be of useful, particularly in the area of English oral communication. In the following paragraphs, CLIL or content and language integrated learning is presented, followed by CBI (content-based instruction).

CLIL has become increasingly popular among teachers and researchers in ELT, especially in Europe. Coyle, Holmes and King (2009, p. 6) define CLIL as "a pedagogic approach in which language and subject area content are learnt in combination". Marsh (2012, p. 28) describes it as an approach that provides learners with "the experience of learning non-language subjects through a foreign language". These definitions, however, do not portray CLIL as similar to the concept of bilingual education or, within the field of ELT, English for Specific Purposes (ESP).

Unlike these two concepts, CLIL-based classrooms require learners to attend to learning content and language in a continuum, a fundamental characteristic which is not apparent in bilingual education and ESP classrooms (Coyle, Hood & Marsh, 2010, as cited in Anderson, McDougald & Medina, 2015). In the CLIL classroom, learners are given the opportunity to improve proficiency level in the language they learn as well as to expand their knowledge about particular subject areas (Anderson, McDougald & Medina, 2015).

A classroom that employs CLIL as an approach to learning is commonly recognised by its distinct activities. In the CLIL-based classroom, Marsh (2002) posits, teachers develop any activity that draws on the use of an additional language as a tool to teach other non-language subjects, such as history and arts. Any activity within the CLIL classroom is generated from a forward curriculum design (Banegas, 2015). The design of this curriculum, according to Richards (2015), begins with discussion about input, followed by determining the process and the outcomes. The decision about teaching methods can be undertaken when syllabus selection has been resolved (Richards, 2015). The teaching methods chosen should clearly reflect three outcomes, namely, “content-related learning outcomes”, “language-related learning outcomes that support the acquisition of content”, and “outcomes related to general learning skills” (Mehisto, Marsh & Frigols, 2008, p. 101, as cited in Banegas, 2015). In brief, CLIL-driven activities do not only focus on improving horizons of knowledge but also the language skills that are needed for carrying out various communicative purposes.

CLIL has been adopted as a teaching approach across countries throughout the world. In Europe, for example, CLIL as a teaching approach has become an important component of the curriculum used widely across all levels of education (Coyle, 2007; Temirova & Westall, 2015). Further, Georgiou (2012) asserts that the adoption of this approach into school curriculum does not only happen throughout Europe, but also Asia and South America. Coyle (2007, p. 546) suggests that the primary reason for the vast development of CLIL is that it “focuses on integrating content and language learning in varied, dynamic and relevant learning environments built on ‘bottom-up’ initiatives as well as ‘top-down’ policy”. That is why CLIL for many scholars is seen as “a major educational innovation, an innovative

methodology, an umbrella term for a variety of educational practices, a new educational model, a new form of education” (Macianskiene, 2016, p. 131).

In the Asian context, the use of CLIL is evident within the ELT domain. Yet, because it is seen as a newly emerging approach in the region, CLIL has not fully drawn a great deal of attention (Yang, 2014). Research shows that there are only a few Asian countries to date that demonstrate the use of CLIL in their curriculum. In Taiwan, for instance, the government has mandated the implementation of CLIL at the tertiary education level, aiming to promote “the internationalisation of education and students’ future employability” (Yang, 2014, p. 362). As Yang (2014, p. 362) put it:

As of 2013, there were 92 CLIL degree-based programmes in 29 universities, all of which received an external MOE evaluation in 2012, except for those which had been accredited by professional organisations such as the Association to Advanced Collegiate Schools of Business (AACSB). This first trial evaluation mainly focused on evaluating the administrative and input levels, namely, the curriculum design, teaching quality and resource provisions.

CLIL application in Japan’s ELT settings is also apparent. Uemura (2013) indicated that the integration of this approach into Japanese language teaching started in 2011, and this integration is predicted to be very significant in the future because of the increasing number of international students studying in Japan. In fact, this increase in overseas students’ participation in Japanese universities is not the sole reason why CLIL is gaining recognition. It also has a range of other perceived benefits. According to Sasajima and Ikeda (2012), as cited in Uemura (2013), CLIL is currently perceived to be the most compelling option for language teaching because the previously employed approaches, such as audiolingualism, grammar translation, and communicative language teaching, have so far yielded unsatisfactory results. This shows that CLIL is seen as having distinct features that allows teachers to approach teaching practices from different points of views.

Despite all the perceived advantages of the CLIL approach, critiques about this approach also persist. Coyle (2007), for example, claims that one of the potential weaknesses of CLIL is its flexibility. This scholar believes that because there are many ways in which CLIL can be applied into different teaching contexts, no single

clear guidance about implementing the approach is available. In fact, Coyle (2007) maintains, in each teaching context, the curriculum of CLIL can be different, but the design of it should be done meticulously. Likewise, Georgio (2012) asserts that miscommunication between teachers, policymakers and researchers can occur because of the way they define the principles of CLIL. Georgiou (2012) maintains that the widespread application of CLIL into classrooms in different contexts may lead to a misapplication of the approach itself because those involved in CLIL teaching may be concerned more with being seen to be exercising the approach which has so far gained popularity in many countries, rather than truly adopting the approach itself.

Research shows that there are a number of ways of anticipating the potential problems of the application of CLIL. First, as reported by Coyle et al. (2010) and Georgiou (2012), it is imperative to design a clear framework of CLIL application so that it is adaptable to various contexts without necessarily ignoring its core principles. Second, it is crucial to ensure that CLIL application also considers learners' uses of their first language as a bridge that aids in their learning (Naves, 2009, as cited in Georgiou, 2012), and that teachers involved in CLIL practice are adequately prepared (Georgiou, 2012). In brief, although CLIL can be applied in various settings to complement existing teaching approaches, its application remains in need of thorough consideration.

Another language teaching approach that has become popular in the 21st century is CBI or content-based instruction. In CBI, the term content refers to "the integration of content learning with language teaching aims" (Snow, 1991, p. 462). Snow (1991) and Schleppegrell, Achugar, and Oteiza (2004) believe that CBI suggests that learning a language and mastering the particular content of a subject should occur in tandem. This belief, according to Lyster and Balinger (2011), as cited in Channa and Soomro (2015), challenges the perspective which sets language teaching apart from content teaching, such as communicative language teaching and task-based language teaching.

Central to CBI is the characteristic of learning a language and a subject matter or content at the same time. The impact of this characteristic can be significant. As

Schleppegrell, Achugar, and Oteiza (2004, p. 67) put it, in a CBI-driven classroom, “teachers can build students’ knowledge of grade-level concepts in content areas at the same time students are developing English proficiency”. For instance, so the argument goes, language learners of English who begin learning some everyday useful phrases may also be able to learn something else, such as how to describe a cultural item and what to say when meeting new people (Schleppegrell, Achugar & Oteiza, 2004). The opportunity for learners to immerse in this type of learning and improve the quality of the learning is supported by the fact that CBI content is challenging and meaningful and that it allows language acquisition to take place (Garcia Mayo, 2015). In other words, CBI can provide learners with the opportunities to access meaningful input, which is influential to their language learning improvement.

CBI is widely used all over the world. These programs fall into two continuum: “content and language integration” (Met, 1999, as cited in Channa & Soomro, 2015, p. 4). The two continuum have different characteristics. For instance, the first continuum, content integration, suggests that teachers use the target language to teach content and to assess learners’ mastery of content, whereas the second continuum, language integration, asks teachers to use content for target language learning and to assess learners’ on language proficiency. This means that whilst language learning is not a priority in the first continuum, it is crucial in the second continuum (Channa & Soomro, 2015). Channa and Soomro (2015, p. 4), who quote Met (1999), further describe these continuum as having six programs, namely “total immersion” (located on the very left side of the continuum), “partial immersion”, “sheltered courses”, “adjunct model”, “theme-based courses”, and “language classes with frequent use of content for language practice” (located on the right side of the continuum).

Each of the programs mentioned above has different principles in its application. For instance, in the immersion program on the left side, the target language is the medium of instruction and exposure to its uses is limited to the classroom context, with support by bilingual teachers (Channa & Soomro, 2015). The right side program, in contrast, suggests that a classroom that aims at teaching content for language learning should create a link to the students’ learning (Channa & Soomro,

2015), which helps facilitate target language learning. This facilitation is doable because learners can see a connection between what they learn and what they do in the classroom, which encourages them to see their learning as a useful endeavour (Channa and Soomro, 2015). On the other hand, unlike the two programs that are located on the left and right side of the continuum, the programs located in the middle of the continuum show that the extent of learning content and learning language vary. This means that to some extent each of these programs may have more focus on content than language improvement, or vice versa.

2.4.4 Post-method approaches

In language pedagogy, the emergence of the notion of post-method approaches to language teaching is believed to be related to how currently employed methods operate and what the results of these methods are. As Kumaravadivelu (2001, p. 537) stated, the development of post-method pedagogy is influenced by the “repeatedly articulated dissatisfaction with the limitation of the concept of method”. This shows that there remain some holes in the implementation of a variety of teaching methods across language classrooms. Kumaravadivelu (2001) believes that this situation has encouraged scholars to either push the limits of the methods and then develop teaching strategies, or focus on improving language teacher education programs. The former consequence is later recognised as the embryo of a post-method pedagogy, “a three-dimensional system consisting of three pedagogic parameters: particularity, practicality, and possibility (Kumaravadivelu, 2001, p. 538). All these parameters are interrelated with one another.

To understand their relationship, it is helpful to look at how each of these parameters is defined. First of all, particularity means uniqueness, and in a language teaching situation, this means taking into account the local context, which can be related to a specific group of teachers teaching a specific group of students with specific learning goals (Kumaravadivelu, 2001). In fact, citing Howatt and Widdowson (2004), Tasnimi (2014) suggests that the local context should not be ignored by any teachers claiming to embrace post-method pedagogy; that it should be incorporated into their classroom teaching practice. Such an embrace indicates that within the framework of

post-method pedagogy in language teaching, no single teaching method is seen as superior to the other because its application is context-dependent.

The second parameter is practicality. Kumaravadivelu (2001, p. 540) defines this framework as pointing to “a much larger issue that has a direct impact on the practice of classroom teaching, namely, the relationship between theory and practice”. Kumaravadivelu (2001, p. 540) believes that theory and practice should go in tandem because they form “a dialectical praxis”. This belief is rooted in the existing phenomenon of today’s classroom pedagogy whereby teachers are encouraged to adhere to any theories prescribed by professionals or government, whilst the teachers’ voices regarding their teaching practice is often put aside (Kumaravadivelu, 2001). The curricula of many countries, such as Indonesia, is centralised, meaning that the government designs the curriculum to be the guideline for schools. This prescribed curriculum helps the government in educational-related evaluation to develop an overall description of the result of the curriculum implementation across educational institutions.

The third parameter is possibility, which refers to the issue of power and dominance. Drawing on this framework, Kumaravadivelu (2001) argues that language teaching should not only be positioned within the classroom boundaries, but also outside the boundaries, and the social and political influences in the society. In fact, any impact which grows out from teachers or students’ classroom interaction can be socially or politically influenced by their life experiences (Kumaravadivelu, 2001). This suggests, that, for example, any given method a teacher uses in the classroom may not work well when it is confronted by students’ perceptions of this method.

In the following section, concepts relevant to language teaching and learning are presented.

2.5 Language learning strategies

Learning strategies can be defined as tools that learners use to improve their learning. In language learning, the strategies are defined as “actions chosen by learners (either deliberately or automatically) for the purpose of learning or regulating the learning of

language” (Griffiths, 2015, p. 426). When learners choose correct actions, they may find ways to improve their language proficiency and self-confidence, whether in teacher-led classroom contexts or in other forms of self-access learning (Cohen, 2005). In fact, when this proficiency improves, further uses of particular learning strategies can boost a specific aspect of language competence: grammatical, sociolinguistic, discourse or strategic competence (Oxford, 1990). Hence, improved self-confidence allows the learners to have greater self-direction, which is important to “the active development of ability in a new language” (Oxford, 1990, p. 10). This suggests that learners who become better self-directed may be more responsible for their own learning and have more feasible ways to foster their learning than their counterparts who have less self-direction.

Language learning strategies are classified in many ways. For instance, Cohen (2005) grouped the strategies into metacognitive, cognitive, socio-affective, retrieval, rehearsal, communication, and cover strategies. Oxford (2013) classified learning strategies into four types: metastrategies, cognitive, affective and socio-cultural interactive. Metastrategies, such as planning, organising, monitoring and evaluating, focus on L2 learning management and control. Cognitive strategies (e.g. reasoning and conceptualising details) assist learners in remembering and processing the L2, whereas affective strategies (e.g. generating and maintaining motivation) help learners in dealing with L2 learning motivation. Socio-cultural interactive strategies, such as overcoming knowledge gaps in communicating, on the other hand, help learners to deal with issues arising from the L2 learning context.

Language learning strategies allow learners to manage their language learning. To make them powerful, the teachers’ role is needed, not only in introducing the learners to the strategies, but also in identifying what strategies they have been using and encouraging them to use strategies effectively (Ehrman, Leaver & Oxford, 2003). Thus, it is important for teachers to be aware of the different roles they can play in the classroom, how and when they can appropriately play a specific role, as well as the established approaches to language teaching and learning.

Learners’ use of learning strategies can be identifiable. Chamot (2004) suggested that there are various ways that teachers can use to figure out what learning strategies

learners use, such as through self-report, interview and questionnaires. Despite their usefulness in uncovering learners' use of certain strategies that are observable, such ways have limitations. For instance, in reporting themselves by writing journals, learners may not report the truth, or in responding to interview questions, they may not be able to remember some details that are related to their thought processes (Chamot, 2004). Chamot (2004), however, suggested that what remains in use extensively in studies related to examining learners' use of learning strategies is questionnaires, one of which is Oxford's (1990) SILL (the Strategy Inventory for Language Learning). SILL is "a standardized measure with versions for students of a variety of languages, and as such can be used to collect and analyse information about large numbers of language learners" (Chamot, 2004, p. 16).

The use of certain learning strategies may remain influential to the improvement in language learners' proficiency. Several studies (e.g. Shmais, 2003; Wharton, 2000) showed that less proficient language learners tended to use more limited learning strategies than those of proficient language learners. With the help from teachers, language learners can find more effective ways to maximise their learning strategies uses. They need to be taught how to use strategies for L2 communication, and this is doable in the L2 learning contexts (Chamot, 2005). In fact, formal instruction of learning strategies does not only help learners to become "better language learners", but also assists teachers in gaining "insights into the metacognitive, cognitive, social and affective process involved in language learning" (Chamot, 2005, p. 112). In the following section, oral communication strategies (OCS), one component of learners' language learning strategies, is presented.

2.5.1 Oral communication strategies

Oral communication strategies (OCS) refer to the means that language learners use to enhance the effectiveness of their oral communication. In a target language communication situation that involves monolingual speakers, for example, the use of the strategies is usually for overcoming the speakers' linguistic deficiencies (Littlemore, 2003). This use of OCS, according to Tarone (1981, p. 419), is subject to a set of criteria, namely:

1. A speaker desires to communicate a meaning to a listener.

2. The speaker believes the linguistic or sociolinguistic structure desired to communicate meaning is unavailable or is not shared with the listener.
3. The speaker chooses to:
 - 3.1 avoid – not attempt to communicate meaning, or
 - 3.2 attempt alternate means to communicate meaning, or
 - 3.3 the speaker stops trying alternatives when it seems clear to the speaker that there is shared meaning.

This set of criteria has distinguished OCS from other strategies, such as production and learning strategies. In Tarone's (1981) words, a production strategy refers to an attempt to use one's linguistic system efficiently and clearly, with a minimum effort. A learning strategy, on the other hand, is an attempt to develop linguistic and sociolinguistic competence in the target language. For Tarone (1981), a production strategy may not involve a negotiation of meaning, because the major purpose of using the strategy, such as a simplification of syntactic structure, is to produce utterances. Likewise, a learning strategy may not include a desire to communicate meaning, because its primary purpose is for learning. Yet, in other studies, for instance in Oxford (1990), OCS are viewed as ways to promote learning for language learners, such as the use of compensation strategies by guessing or asking questions to clarify things.

OCS have different functions. Tarone (1981), for example, considers them to be strategies that serve an interactional function, and defines them as a "mutual attempt of two interlocutors to agree on a meaning in situations where requisite meaning structures do not seem to be shared" (p. 288). Accordingly, Ghout-Khenoune (2012) sees OCS as learners' verbal and non-verbal means of overcoming communication difficulties, as ways of negotiating meaning and remaining involved in the conversation. On the other hand, Bialystok (1990, as cited in Brett, 2001, p. 53) considers OCS as "evidence of underlying mental processes". This definition suggests that the use of OCS is influenced by the need to overcome the perceived difficulties which occur when communicating a message in a target language, without necessarily engaging the interlocutor in negotiating meaning. Smith's (2003) definition of OCS as the strategies that learners use to avoid and handle communication difficulties seems to support Bialystok's classification.

An extended concept of OCS is proposed by Dörnyei (1995). Dörnyei (1995) stated that the term OCS can also include ways of coping with processing time pressure in the target language interaction. That is why the strategies like the use of fillers, hesitation devices, and self-repetition, should be considered as part of OCS. However, despite such diverse definitions, Brett (2001) contends that these classifications of OCS refer to the same or similar entities. The use of OCS should be considered as a means by which language learners find ways to convey meaning, to negotiate, and to reach a communicative goal by managing their linguistic gaps (Jamshidnejad, 2011). Table 1 below represents one sample of OCS classification that is based on several OCS scholars, such as Tarone (1977), Faerch and Kasper (1983), and Bialystok (1990). The table is adapted from Dörnyei (1995, p. 58).

Avoidance or Reduction Strategies	Achievement or Compensatory Strategies	Stalling or Time-gaining Strategies
<ul style="list-style-type: none"> • Message abandonment • Topic avoidance 	<ul style="list-style-type: none"> • Circumlocution • Approximation • Use of all-purpose words • Word-coinage • Use of non-linguistic means • Literal translation • Foreignizing • Code switching • Appeal for help 	<ul style="list-style-type: none"> • Use of fillers/hesitation devices

Table 1 OCS classification (adapted from Dörnyei, 1995, p. 58)

Opinions on the use of OCS instruction in formal language classrooms vary widely and several researchers have questioned the significance of educating learners in the use of these strategies. Kellerman (1991), for example, believed that learners develop their L1 strategic competence and use it in their target language interaction, so the teaching of strategies is unnecessary. Similarly, Bialystok (1990, p. 147) contended that the primary goal for language teachers should be teaching students language, not strategies. However, Willems (1987) argued that language learners might find themselves in a situation that requires them to express themselves using their innate strategic and discourse competencies while interacting using the target language they are learning. This implies that teaching language learners some ways to help them

mobilize their innate strategic and discourse competencies would be relevant to and useful for their efforts to become competent speakers of the language.

Despite the research that dismiss OCS instruction, Dörnyei (1995) suggests that if a language teacher considers that OCS instruction is necessary, the teacher may find it useful to raise learners' awareness about OCS, to provide some samples of OCS use, and to encourage them to apply certain OCS in their L2 oral communication. Although OCS instruction does not always improve learners' oral communication skills, learners may become aware of specific strategies that they can use to improve their L2 oral communication (Nakatani, 2005). Maleki (2007) suggests three phases of OCS instruction (as seen in Figure 2 below). In the first phase, teachers engage learners in a discussion of their language learning processes, approaches, needs and learning resources that they can find outside the classroom. In the second phase, teacher can teach particular OCS which suits their learners' learning approaches or needs. In the third phase, teachers provide their learners with some activities that can stimulate learners to use OCS and encourage them to be aware of specific strategies that they can use in specific oral communication contexts. Maleki (2007) believes that the idea of OCS instruction is to help learners find ways to maintain their involvement in L2 oral communication.

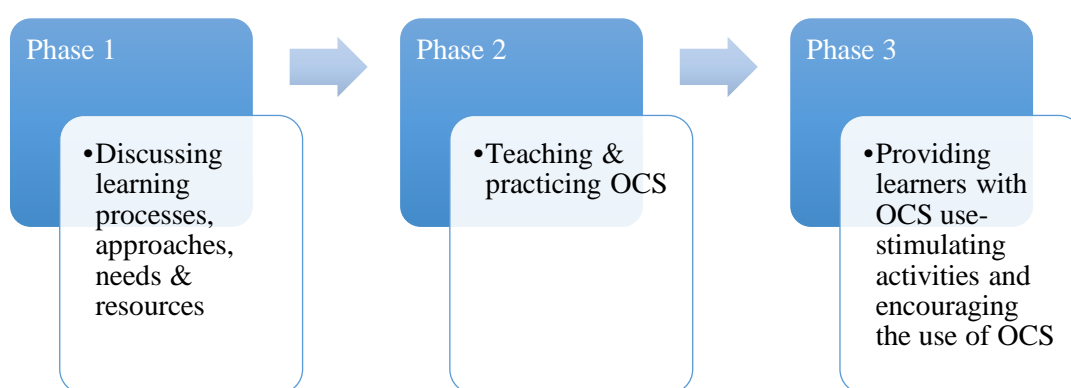

Figure 2 Phases of OCS instruction (adapted from Maleki, 2007, p. 593)

The importance attributed to OCS is noticeable in many empirical studies. For instance, Littlemore (2003) conducted a study to examine the effectiveness of compensation strategies, and related them to the different types of learning styles. Using a booklet which had a number of items to describe, he elicited data from 82

French speaking, university-level learners of English. The findings revealed that the ectenic learners participants (learners who need conscious control of what they are learning) tended to use Poulisse's (1993) reconceptualization strategies (also known as the circumlocution strategies in Dörnyei's CS classification), which were found to be the most effective strategies to guarantee successful communication.

In the Arab world, the importance of OCS is also evident. Rabab'ah and Bulut (2007), for example, investigated the use of achievement strategies, reduction strategies and other performance problem-related strategies (e.g. asking for clarification) in an oral discourse. Using interview and role-play techniques, these researchers collected data from second year students studying Arabic as a second language (ASL) in the Arabic Language Institute at King Saud University in Riyadh, Saudi Arabia. The findings showed that the ASL learners used a wide range of strategies, with paraphrasing being most widely used to cope with their limited linguistic resources in the Arabic language. It also revealed that the use of strategies varied between participants from different cultural and educational backgrounds, and different language backgrounds. These differences, according to Rabab'ah and Bulut (2007), could be attributed to learners' mother tongue influence, and educational and cultural backgrounds.

In addition to these two studies, Omar, Embi and Yunus (2012) researched the use of OCS in online discourse in Malaysia. Using an information sharing task via Facebook, these researchers investigated 28 undergraduate students taking a communication course in a university in Malaysia. These researchers found that the participants, who had different levels of English proficiency, employed achievement OCS to get their messages across during an information-sharing task. One of the most common strategies that they used was literal translation, followed by approximation and code-switching. The participants also utilized other means, such as online translation and emoticons, to help express themselves during the task.

These studies have shown that language learners use OCS to find ways to communicate their intended messages to interlocutors in oral and written communication situations. They also indicate that beginner language learners can make use of certain OCS to cope with their target language linguistic difficulties and

that strategy instruction can be part of a language curriculum. The use of OCS, in this sense, may help language learners foster their learning.

2.6 Summary

This chapter has described the role of English in today's world, particularly in the Indonesian context, the nature of oral communication and some strategies learners use to communicate using the language they are learning. It has also presented several conceptual areas and approaches to language learning that are relevant to the present study. In addition, the chapter has reviewed a number of empirical studies relevant to these concepts and shown that OCS in English Education programs in Indonesia has received little attention in the research.

Chapter 3

Research Methods

This chapter introduces the research purpose and orientation, the research design that was chosen to examine the research questions set out in Chapter One, as well as the ethical issues involved. A section on triangulation then follows. The subsequent section outlines the data collection, which consists of participants and sources of data. This is followed by an outline of the processes involved in data analysis. Ethical issues concerning the research process are then clarified. The chapter concludes with a brief summary of the chapter.

3.1 Research purpose and orientation

Determining research purpose can help researchers select the right approach to their research. Yin (1984) suggests that to help determine the most appropriate research approach, researchers need to take into account the purpose of their research. Marshall and Rossman (1995) categorise research purpose into four types: exploratory, explanatory, descriptive and predictive. Exploratory research focuses on understanding a particular phenomenon. It is used when important variables are to be discovered, and hypotheses generated for further research (Marshall & Rossman, 1995). One example of a typical data collection technique of this approach is using participant observation and in-depth interviews (Marshall & Rossman, 1995).

Explanatory research, on the other hand, is carried out in order to explain the causal relationships among the variables in the phenomenon and through the use of document analysis, survey, interview schedule and observation (Marshall & Rossman, 1995). Descriptive research, according to the authors aims at documenting “the phenomenon of interest” by using the same data collection sources of the explanatory research. Predictive research attempts to “predict the outcome of the phenomenon” and “to forecast the events and behaviours resulting from the phenomenon” (Marshall & Rossman, 1995, p. 41).

The purpose of this present study reflects the first type of research, i.e. to examine ‘little-understood phenomena’ by looking at the “salient themes, patterns, categories in participants meaning structures” (Marshall & Rossman, 1995, p. 41). The study sought to examine themes associated with English language lecturers’ voices about

oral communication strategies instruction. Driven by the research aims, a qualitative research design was adopted.

3.2 Applying qualitative research design

Qualitative research design is commonly used by researchers to learn or generate ideas from human behaviours. According to Denzin and Lincoln (2003), qualitative research design emphasises the qualities of entities and focuses on process and meanings that are not experimentally examined or measured. Unlike quantitative researchers who seek answers to questions that centre on causal relationships by means of measurement, qualitative researchers seek answers to questions that stress how people create and give meaning to their social experiences (Denzin & Lincoln, 2003). The main reason for selecting this approach is to collect data “based on words from a small number of individuals so that the participants’ views are obtained” (Cresswell, 2012, p. 16).

To obtain the soundest way of understanding participants’ views through a qualitative research approach, a constructivist paradigm was applied. Unlike other paradigms, such as positivism which highlights single reality “apart from human apprehension of it” (Lincoln & Guba, 1985, p. 270), constructivism accounts for multiple realities that are socially constructed in natural settings and acknowledges subjectivity. In other words, constructivism considers knowledge or reality as a dynamic construction that needs to be interpreted. After all, according to Denzin and Lincoln (2003, p. 33) “all research is interpretive; it is guided by a set of beliefs and feelings about the world and how it should be understood and studied”.

The constructivist paradigm is closely related to the research method set out in the later section of this chapter. This relationship is visible in the paradigm’s “social constructivist epistemology” (Taylor et al., 2012, p. 26). In constructivism truth or reality is socially constructed and “made out of the interaction and discourses of a particular time in history”, representing different kinds of existing reality in that society (Roberts et al., 2001, p. 48-49). Thus, observable themes derived from the data analysis on the participants’ voices are all be treated as representations of reality. On the basis of this consideration, this present study used a case study

method (Yin, 1984) as an approach to data collection in an attempt to address the following key research and guiding questions.

Key research question	What are the perspectives of lecturers on English oral communication strategy instruction in the English Education Program in a university in Indonesia?
Guiding research questions	<ol style="list-style-type: none"> 1. What are lecturers' objectives in teaching English oral communication? 2. What are lecturers' perspectives of pre-service teachers' English oral communication challenges? 3. How do lecturers cope with these challenges? 4. Do lecturers encourage pre-service teachers to use English oral communication strategies in and out of classes?

Table 2 Key and guiding research questions

3.3 Data Collection

3.3.1 Participants

The research was conducted at the Department of English Education (DEE) at a university located in the northern part of Indonesia. This university is one of the English language teacher education institutions which caters to high school graduates who want to pursue careers as English language school-teachers. The department is under the Faculty of Letters and Culture. It offers English Education programs at the undergraduate level that requires approximately four years of study for the completion of the program. The research was conducted with two groups of participants, which is briefly described in the following tables.

Names	Personal Details			
	Qualification (country)	Year of teaching experience at ETEP	Language spoken	Other professional duties
Lecturer 1	Bachelor in English Education (Indonesia) Master's Degree in Leadership and Management (Australia)	App 5 years	Bahasa Indonesia, Bahasa Gorontalo, English	N/A

Lecturer 2	Bachelor in English Education (Indonesia) Master's Degree in Linguistics (Indonesia)	App 9 years	Bahasa Indonesia, Bahasa Gorontalo, English	N/A
Lecturer 3	Bachelor in English Education (Indonesia) Master's Degree in Applied Linguistics (Australia) Ph.D in Curriculum and Instruction (the USA)	App 15 years	Bahasa Indonesia, Bahasa Gorontalo, English	Head of Department Department of English Education (Postgraduate Program)
Lecturer 4	Bachelor in English Education (Indonesia) Master's Degree in Applied Linguistics (Australia) Ph.D (Australia)	App 20 years	Bahasa Indonesia, Bahasa Gorontalo, English	Vice Dean Faculty of Literature and Culture (Undergraduate Program)
Lecturer 5	Bachelor in English Education (Indonesia) Master's Degree in Management and Leadership (Australia)	App 9 years	Bahasa Indonesia, Bahasa Gorontalo, English	Head of Language Laboratory Faculty of Literature and Culture
Lecturer 6	Bachelor in English Education (Indonesia) Master's Degree in Applied Linguistics (Australia)	App 13 years	Bahasa Indonesia, Bahasa Gorontalo, English	Secretary Centre of Academic Quality Assurance <i>State University of Gorontalo</i>
Lecturer 7	Bachelor in English Education (Indonesia) Master's Degree in Linguistics (Indonesia)	App 25 years	Bahasa Indonesia, English	Head of Library Faculty of Literature and Culture
Lecturer 8	Bachelor in English Education (Indonesia) Master's Degree in American Studies (Indonesia)	App 8 years	Bahasa Indonesia, Bahasa Gorontalo, English	Staff Centre of Academic Quality Assurance <i>State University of Gorontalo</i>
Lecturer 9	Bachelor in English Education (Indonesia) Master's Degree in Language Education (Indonesia)	App 6 years	Bahasa Indonesia, Bahasa Gorontalo, English	N/A
Lecturer 10	Bachelor in English Literature (Indonesia) Master's Degree in Language Education (Indonesia)	App 9 years	Bahasa Indonesia, Bahasa Gorontalo, English	N/A

Lecturer 11	Bachelor in English Education (Indonesia) Master's Degree in Language Education (Indonesia)	App 9 years	Bahasa Indonesia, Bahasa Gorontalo, English	N/A
-------------	--	-------------	---	-----

Table 3 Participants' profile (the lecturers)

The first group of participants were English language lecturers (Lecs: $n = 11$) who were working at the department. These lecturers (two males, nine females) were from the same L1 background. All of them were Indonesian and speakers of the same vernacular of Gorontalo. The majority of them had more than five years' English language teaching experience, with two of them having a doctoral degree qualifications from overseas universities. Nine of them had masters' degree qualifications. Among them, three had graduated from Australian universities, and the others had graduated from Indonesian universities. Six of these lecturers had administrative positions, i.e. Head of Department (Postgraduate Program), Vice Dean, Head of Language Laboratory, Secretary to Centre of Academic Quality Assurance, Head of Library, and Staff at Centre of Academic Quality Assurance.

Data were also gathered from a group of seven student-teachers (STs), who were currently doing an undergraduate degree in the English Education program at the DEE. They were all Bahasa Indonesia speakers, but not of the same vernacular. Among them, two spoke a language other than Bahasa Gorontalo language, and one spoke only Bahasa Indonesia and English. Three of the student-teachers had teaching experience as English language teachers, while the others had not. Bahasa Indonesia was the first language that they shared. The table below summarises this information.

Names	Personal Details			
	Semester	Teaching experience (Y/N)	Language spoken	Other relevant experiences
Pre-service student 1	8	Y	Bahasa Indonesia, Bahasa Gorontalo, English	Established an English training institution
Pre-service student 2	6	Y	Bahasa Indonesia, Bahasa Gorontalo , English	N/A

Pre-service student 3	8	Y	Bahasa Indonesia, Bahasa Bolaang Mongondow, English	N/A
Pre-service student 4	6	N	Bahasa Indonesia, Bahasa Gorontalo, English	N/A
Pre-service student 5	2	N	Bahasa Indonesia, English	Joined an English Debate Competition
Pre-service student 6	4	N	Bahasa Indonesia, Bahasa Gorontalo, English	Worked as a tourist guide
Pre-service student 7	2	N	Bahasa Indonesia, Bahasa Bolaang Mongondow, English	N/A

Table 4 Participants' profile (the pre-service teachers)

To gather data from the participants, the present study used a semi-structured interview schedule on a face to face basis, which was audio recorded. Other sources of data were also used to corroborate findings. The subsequent section clarifies each of these sources of data.

3.3.2 Sources of data

The sources of data for the present study were interview schedules, classroom observations and document analysis. Collecting data from these different sources employs a triangulation technique. Triangulation refers to the use of various data collection methods and different sources of data in order to arrive at answers to the research questions (Mackey & Gass, 2005). Mackey and Gass (2005) classify three types of triangulation, namely, theoretical triangulation (using different perspectives to examine the same set of data), investigator triangulation (using various observers or interviewers), and methodological triangulation (using multiple research methods). Erlandson et al. (1993) include another type of triangulation, namely, data triangulation (collecting data from different times, spaces and persons). Using triangulation should help ensure the trustworthiness of the research.

The present study applied methodological triangulation and data triangulation. The methodological triangulation involved interviews, classroom observations, and document analysis, whereas the data triangulation comprised interviewing the

English language lecturers and the pre-service teachers (PSTs). Interviewing the PSTs was done in order to justify relevant responses provided by the lecturers. The data collected from the interviews were supplemented with data from classroom observations and syllabuses. The observations were done in a number of lessons from the Speaking and Listening unit. Further details with respect to procedures for collecting data is presented in the following section.

3.3.2.1 Interviews

The primary data collection instrument for this present study was a personal interview schedule. The selection of this instrument was primarily due to its characteristics. Bryman (2012) argues that interviews are commonly used in qualitative research design because of their flexibility. Unlike surveys, interviews allow participants “to open up and express themselves in their own terms and at their own speed” (McKay & Gass, 2005, p. 173). One of the major advantages of using an interview schedule as a research instrument, according to Creswell (2012), is that it helps researchers to select and classify kinds of information expected to answer the research questions by asking specific questions and doing a follow up to the interviewee’s responses.

Interviews with the participants was possible in groups. However, personal interviews were chosen over group interviews to enable the interviewees to talk comfortably (Creswell, 2012) and to avoid what is called by Mackey and Gass (2005) the “Hawthorne” effect, a situation where participants behave differently because they realise that they are under investigation. A semi-structured format (audio-recorded) was followed in which each participant responded to a number of open-ended questions, and a set of follow up questions when needed. Creswell (2012, p. 218) suggests that asking an open-ended question “... allows the participant to create the options for responding”, without necessarily leading participants in their responses to some expected answers.

In order to obtain rich data, the questions for the interviews were carefully worded. This was done by following the guidelines for structuring questions according to Patton (1980, as cited in Erlandson et al., 1993, p. 88). Patton proposes six basic

kinds of questions that can be used to gather various kinds of data. The questions relate to experience, opinions, feelings, knowledge, sensory, and background or demography. In addition to carefully wording the questions, the interviews were piloted with two English language lecturers, following the chosen approach. The first pilot was conducted with a lecturer from a teacher education institution in Malang, located in the Province of East Java, Indonesia, who was doing a Ph.D at Curtin University. Feedback from this lecturer was used to improve the interview protocols.

Once interview protocols had been refined, the second pilot was carried out with a lecturer from a teacher education institution in the Province of Gorontalo. This was done via the telephone. The lecturer is currently doing a Ph.D degree in a university in New South Wales, Australia. After all improvements to the interview protocols were made, collecting data at the research site commenced.

The lecturers were located by initially contacting the head of the department for research approval. All the lecturers were contacted via email in order to invite them to participate. The lecturers were selected using a purposive sampling method. Using purposive sampling to gather data helps qualitative researchers understand the central phenomenon in their research by collecting data from deliberately selected individuals and sites (Creswell, 2012). Setting boundaries (focusing on particular coursework units, i.e. Speaking and Listening) assisted in the collection of data that connected to the objectives of the research and provided examples to examine in depth (Miles & Huberman, 1994).

The interviews took place at *Universitas Negeri Gorontalo*, a state-owned university, from 18 May, 2014 until 2 June, 2014. They were of 45 to 60 minutes duration for each participant as the whole. However, a number of interviews lasted only 25 to 45 minutes. Some of the participants agreed to be interviewed in English, while others preferred to switch between English and Bahasa Indonesia. There were also some participants who decided to use Bahasa Indonesia solely during the interviews.

To collect data from the student-teachers for triangulation, a conceptually driven sequential sampling was utilised. This type of sampling suggests that one participant can lead a researcher to another participant who may provide him with data that are

relevant to his/her research objectives (Miles & Huberman, 1994). Two criteria for selecting the PSTs were applied: teaching experience and academic reports. A semi-structured interview with one of the targeted PSTs led the researcher to another PST for a subsequent individual interview, which was audio recorded. Eventually seven PSTs were interviewed. Looking at a large number of participants was not the aim of this research because the objective was to learn from individuals, not to make generalisations from the findings.

Data from the interviews was supplemented with data obtained from other sources, namely observations and documents. These are elaborated upon in the following sections.

3.3.2.2 Observations

This present study used observations to help establish trustworthiness for the reasons discussed here. First, as Merriam (1998) points out, observations are usually carried out to corroborate findings from other sources of data collection, namely interviews and document analysis. Second, as Marshall and Rossman (1995, p. 79) assert, observation is “the systematic noting and recording of events, behaviors, and artifacts (objects) in the social setting chosen for study”. Observation can be conducted through participant observation, field observation, qualitative observation, direct observation, or field research” (Lofland, 1971, as cited in Patton, 1980, p. 124). In the present study, direct observation was selected because, as Patton (1980) asserts, it helps researchers obtain certain information that may not emerge during interviews due to the unwillingness of participants to talk about sensitive matters.

The observations were done in a number of Speaking and Listening classes and the focus was on the lecturers. Five observations were done in Listening classes (five classes) and five in the Speaking classes (five classes). Each of these classes was observed once. Given that observing any event is difficult, an observation checklist based on the work of Merriam (1998) was used to record relevant information. The items included settings, participants, activities and interactions, conversation, subtle factors and the researcher’s behaviour. In this research, the focus of what to observe was on the activities and interaction of the lecturers. To record these activities and

information, field-notes were used which contained descriptive and reflective field-notes (Creswell, 2012). The descriptive field-notes recorded information related to the first five checklist elements, whereas the reflective field-notes recorded information about the last item on the checklist (Creswell, 2012).

The initial observation plan suggested that each Speaking and Listening classes would be observed once or twice for approximately 100 to 150 minutes. The length of the observation duration corresponded with the duration of each of the coursework units, in which one credit of the unit equals 50 minutes. Speaking and Listening units are worth two credits, which means 100 minutes of meeting time. However, because many of the lecturers preferred being observed for less than one hour, the observations were done for only approximately 45 to 60 minutes of a meeting time, with one observation for each class. The main reason for this decision was to minimise the influence of psychological-related disruption on the lecturers and their PSTs that may occur when observation lasted for more than an hour.

3.3.2.3 Documents

In addition to observing the lecturers' lessons, this present study also used documents as another source of data. According to Yin (1984), the use of documents in qualitative research assists in establishing the corroboration of information obtained from other sources. In this present study, the documents used for the corroboration were teaching syllabuses from Speaking and Listening lessons. The syllabuses were selected because they were considered to be relevant sources to corroborate data obtained from the interviews and the classroom observations. In determining the quality of the syllabuses, two questions, as suggested by Merriam (1998), were taken into consideration. These were (1) whether or not the syllabuses offered information related to the research questions, and (2) whether or not the syllabuses were accessible. In addition to these syllabuses, a number of the Indonesian government regulations or laws relevant to the study were addressed.

Using documents as a source of data in research may pose some challenges for researchers. One of the the challenges is that they can be difficult to find and might lack authenticity and accuracy (Creswell, 2012). Despite this challenge, the

researcher decided to collect data from documents because as Merriam (1998, p. 126) argues, documents fit nicely with qualitative case studies because “they can ground an investigation in the context of the problem being investigated”. In fact, because the researcher had been working with many of the lecturers, the researcher found the challenge a minor issue. To collect the syllabuses, the lecturers who were senior lecturers were approached. They were asked because they were also serving as the heads of the teaching teams for each of the coursework units (Speaking and Listening). The syllabuses obtained were developed by the teaching team.

3.3.3 Data analysis

The approach to data analysis in this present study was informed by Patton’s (1980) evaluation of qualitative research design. Patton (1980) distinguishes three levels in evaluation, namely, analysis, interpretation and evaluation. At the analysis level, qualitative researchers seek to organise units of data into specific patterns, before subsequently moving up to the interpretation level which aims at “attaching meaning and significance to the analysis, explaining descriptive patterns, and looking for relationships and linkages among descriptive dimensions” (Patton, 1980, p. 268). On top of these two levels, the evaluation is where the researchers attempt to assess and determine the quality of the analysis and interpretation results (Patton, 1980). The research used in this study used all these three levels to address the key research question.

In order to accomplish the analysis level, this study adopted Miles and Huberman’s (1994) flow model. This model consists of three concurrent flows of activities, namely data reduction, data display, and conclusion drawing/verification, which goes hand in hand with the data collection (Erlandson, Harries, Skipper, & Allen, 1993). The data reduction involves a set of integrated processes, ranging from selecting to transforming data. Such processes provide a framework for the researcher to proceed to coding. Coding is “the process of segmenting and labelling text to form descriptions and broad themes in the data” (Creswell, 2012, p. 243). To do the coding in this research, the researcher used the steps below as suggested by Creswell (2012, p. 244).

1. Initially read through text data
2. Divide the text into segments of information
3. Label the segments of information with codes
4. Reduce overlap and redundancy of codes
5. Collapse codes into themes

To help develop appropriate codes, initial coding of the transcripts from the pilot interviews was done. The codes developed were informed by the research question and the conceptual framework of this present study. The actual coding of the data gathered from the participants was done individually in two different periods of time. The reason for doing this individual coding was because it helped the researcher better understand the data, which in turn enabled the generation of appropriate codes for each unit of data.

The first period of coding was done during the data collection, after each interview had finished. This was followed by a member checking process, in which all the participants were requested to examine their interview transcripts for the accuracy of transcription and coding. After feedback from the participants was collected and analysed, the second period of coding began. With regard to data display, this research used tables and narrative texts. The narrative texts contained quotes of interviews with the participants to validate the data displayed in the tables.

In the first step of the analysis, the audiotape recordings of interviews were transcribed verbatim. The transcription followed a set of rules that the researcher developed, as described below.

Language forms	Transcription modes
<i>Uhm, er, etc</i>	are not transcribed, except when they occur as single turns
Repetitions and false starts	are not transcribed
Numbers	are transcribed using numbers and words
Dots	(...) are used to indicate pauses; (... .) are used to mark sentence fragments.

(Laughing)	is used to show the act of laughing
Short utterances showing overlaps	are not transcribed. However, to ensure the smoothness of flow of turn taking, the transcription of the utterances is retained. Also when longer utterances overlaps are shown, the next turn also includes these utterances as the beginning of the sentences.
“What’s that?”	are not transcribed.
Unclear utterances	are transcribed using XXX

Table 5 Transcription conventions

The transcription of the interviews done in Bahasa Indonesia was followed by a translation into English. The translations were done individually in order to remain closer to the data being analysed. When all these transcriptions and translations were accomplished, the analysis proceeded to the second step, coding. This step was followed by generating themes for similar codes. Prior to the accomplishment of the coding and the generating of themes, the transcriptions of the interviews were sent to all the participants for cross-checking purposes. This was done as a part of the third activity in the flow model, conclusion drawing/verification, which suggests that the process of drawing conclusions or verifying data should commence from the beginning of data collection. Further details regarding this verification of data are outlined in the following section.

3.4 Trustworthiness

To ensure trustworthiness, this study applied triangulation, a technique which has been described in the previous section of this chapter. In addition to triangulation, it established a number of criteria, as suggested by Erlandson et al. (1993), which included:

- Credibility – by providing all the participants with accounts of what they said during the interviews or of what the researcher observed in the classrooms for member checking purposes. This was done by sending them copies of these accounts.
- Transferability – by providing the audience with rich accounts of the context of the research site and its participants because, as Erlandson et al. (1993, p.

17) suggest, a context “provides great power for understanding and making predictions about social settings”. This helps the audience make tentative judgments about the applicability of findings of this research for other contexts (Erlandson et al., 1993). Details of this context are given in Chapter 1.

- Confirmability - by providing all evidence in order to help other researchers who are willing to repeat a similar study in different settings. Such evidence (including electronic copy) is stored securely and can be accessed for the purpose of other research upon approval of the researcher and the researcher’s supervisors.
- Dependability - by providing complete records of all stages in the research process so that they can be tracked by an audit to make judgments associated with this research if required. All records pertaining to this research are stored securely (including electronic copy) by the researcher.

3.5 Ethical issues

The major ethical issues arising from this research were associated with the data collection approval, research report, and research data storage. To address these issues, deliberate procedures were undertaken. Permission to gain data and access to the participants was obtained from the Dean by contacting the Head of the Department of English Education. When the permission was granted, all of the participants were approached personally and invited to participate voluntarily.

Information related to the research site has not been explicitly articulated, except the name of the area where the site is located. With respect to the participants, all of the participants were requested to read an information sheet and to sign a consent form. Their identity is protected in the research report by assigning pseudonyms. The original research data are retained by the School of Education at Curtin University. Copies of all collected data (including USBs) are stored in secure locked storage provided by the Faculty of Humanities. All electronic data are saved on a computer that is password protected and only accessible by the researcher’s supervisor and the researcher. All these data will be stored for a period of five years after which it will be destroyed.

3.6 Summary

This chapter has outlined the research design and described the data collection used in detail. A qualitative approach, which was informed by a constructivist paradigm, was adopted in order to bridge the gap in the literature of English language lecturers' voices regarding teaching oral communication strategies. The research data were gathered primarily through using individual semi-structured interviews with selected English language lecturers who were teaching at a university in the Province of Gorontalo, Indonesia. Other sources of data, namely, interviews with selected pre-service teachers majoring in Bachelor of Education in English, syllabuses and classroom observations, were used to corroborate the main findings from the interviews with the lecturers. Trustworthiness was achieved through the establishment of four criteria (credibility, transferability, dependability and confirmability) and the adoption of triangulation in the data collection. Finally, efforts were made to ensure the integration of ethical considerations into the research process.

Chapter 4

Findings

This chapter presents the responses of both the lecturers and the pre-service teachers (PSTs) to the interview questions arising from the key research question and the subsidiary questions, as well as an analysis of those responses into a number of themes. To begin with, the key and subsidiary research questions are outlined once more.

Key research question	What are the perspectives of lecturers on English oral communication strategy instruction in the English Education Program in a university in Indonesia?
Guiding research questions	<ol style="list-style-type: none">1. What are lecturers' objectives in teaching English oral communication?2. What are lecturers' perspectives of pre-service teachers' English oral communication challenges?3. How do lecturers cope with these challenges?4. Do lecturers encourage pre-service teachers to use English oral communication strategies in and out of classes?

Table 6 Key and guiding research questions

The following sections present the findings related to the four subsidiary questions, starting with lecturers' objectives in teaching English oral communication.

4.1 Lecturers' objectives in teaching English oral communication

The lecturers reported that they had various objectives in teaching English oral communication. Table 4 below summarises these objectives, which are categorised into five themes, namely, teaching to improve own learning, improving PSTs' English language speaking skills, improving PSTs' English language listening skills, developing PSTs' confidence, and helping PSTs' pass the TOEFL. In the following sections, each of these themes is expanded upon.

Codes	Themes
Opportunity to learn	Teaching to improve own learning
PSTs can speak English fluently PSTs can speak English in public PSTs have native-like pronunciation in English PSTs can pronounce well in English	Improving PSTs' English language speaking skills

PSTs can improve their English language listening skills	Improving PSTs' English language listening skills as a vehicle to improved L2 oral communication
PSTs develop confidence	Developing PSTs' confidence
PSTs develop strategies for passing the oral communication component of TOEFL	Helping PSTs pass the TOEFL

Table 7 Objectives in teaching English oral communication

4.1.1 Teaching to improve own learning

Some lecturers confided that they taught English oral communication classes (speaking and listening units) in order to have the opportunity to learn and improve their own English oral language skills level. Lec1, for example, thought that 'to learn while teaching' is an effective way for her to practise speaking English. She associated lecturers' successful L2 speaking skills with taking opportunities to teach the skills in the classroom:

Yeah, you know, writing and speaking is a productive skill, ya. So, it gives me opportunity to learn, too. Because we are teaching language that all we need is practicing that...So I think an effective way for me to learn while teaching is by doing that... (Lec1: 39)

Similarly, Lec11 stated that she chose to teach listening because she wanted to learn some ways to improve her own English listening skill level. Lec11 realised that her English listening skill level was not very proficient, and it was difficult for her to do her best when teaching the IELTS and TOEFL listening sections. Therefore, she decided to teach listening in the hope of enhancing her own English listening skill:

Ya I choose this subject so...I have some reason. I want to improve my skills, special is listening, is reading. So, sometimes I found difficulties in...when I follow the test. So sometimes I...the score is low in listening comprehension when I follow the test IELTS, TOEFL. This is low. So I choose the subject, so it is improve my skill. (Lec11: 30)

Accordingly, Lec8 also showed similar concern regarding improving his speaking skills. Although Lec8 did not explicitly mention teaching the L2 oral skills course in order to improve his own speaking skills and English proficiency, he admitted that he was not confident with his current level of L2 oral proficiency. He realised that he was a language model for his PSTs, and giving non-standard examples of, for instance, English pronunciation, would not be appropriate for his PSTs. Therefore, he

felt that he needed to take certain courses that helped him develop his English oral proficiency level:

Lec8 : ... So actually I realise that my big problem was in structure and also in speaking because in after I followed the TOEFL test I found that my structure was usually the score was in the lowest in the lower score. And in speaking usually I'm worried because when I pronouncing something then and then the words was mispronounced or maybe it's spelling in not proper pronunciation it will ya it's like what is? I must (54)

Ab55 : A big challenge?.

Lec8 : Ya. I'm as a lecture and then I pronounce not as the proper pronunciation it makes me feel that it's I must sample for the student. I'm as a guide for them and also I pronounce correctly. So sometimes I wonder that I can improve my speaking ability by following some courses maybe. (55)

These lecturers' responses showed that there remained gaps in the lecturers' pedagogic (subject matter) and language skills competence. The lecturers were aware of these gaps, and understood what consequences these gaps had on the PSTs' L2 learning experience. Whilst some lecturers hoped to attend "some courses" (or professional development) that would help them develop their competence as lecturers, particularly in language skills area, other lecturers chose to develop their oral English language competence by teaching. The following section describes lecturers' objectives in improving PSTs' English language speaking skills.

4.1.2 Improving PSTs' English language speaking skills

The lecturers confirmed that helping their PSTs to improve their English speaking skill level was their main objective in teaching English oral communication skills. For this reason, Lec2 said that she expected to see her PSTs demonstrate some basic qualities of successful English language learners, namely, being fluent, communicative and brave. As Lec2 put it:

Absolutely they will be able to speak fluently, communicatively, and also they will be encourage to explore their speaking quality through my subject that is Speaking 1. I mean this is for their basic knowledge. So from this subject they can be encourage, can be brave to do speaking in the higher level I mean. (Lec2: 21)

Lec5 corroborated this and reported that he wanted to see his PSTs articulate their ideas freely and clearly in oral English communication. He emphasised the

importance of correct pronunciation, vocabulary and grammar, although in reality, many English language learners would find it challenging to realise these. Lec5 thought that following the rules of standard English language when speaking English was imperative:

So the objective of Speaking 3 is at the end of the course that the students are able to express their idea based on standard of English in terms of pronunciation, vocabulary, the use of grammar in some kinds of broad topics. So they can express their opinion or idea freely. (Lec5: 6)

Likewise, Lec7, who was teaching listening, said that in his classes he integrated an English speaking skill component, namely pronunciation work, by asking his PSTs to read out their notes after listening to some English language recordings:

No, but they also speak. They write down what they hear from the conversation in the audio in the listening or maybe from the book. And also they try to mention, to speak what they write. (Lec8: 39)

Improving PSTs' speaking skills was stated in the syllabuses of the speaking classes. For instance, in the Speaking 1 syllabus, one of the objectives is that the PSTs are expected "to be able to communicate interactively in English about various situations, stories and purposes (e.g. a situation in a restaurant, a market, which delivered through some forms such as conversation, monologue and so forth)". At the same time, in the Speaking 3 Syllabus, the first objective suggests that the PSTs need "to be able to speak up".

Evidence of these objectives was seen in the speaking classes, as shown in the following excerpts of classroom observation field-notes.

To start the class, the lecturer introduced the researcher. Then, she talked about what the students were going to do today. Later on, she asked for a volunteer to start the rehearsal as today the students were about to perform something they like to do. It was impressive to see how the lecturer and the students interacted using English. After each performance from the students, the lecturer encouraged other students to participate by giving comments or asking questions to the performers. (Lec4's class, 19/5/2014)

The lecturer began the class by introducing the researcher. Then, he reminded the students about the research proposal presentation that they were going to do today. He talked in English and kept the use of Indonesian at the minimum level. He then asked a volunteer student to start presenting his research proposal. After that, this lecturer encouraged other students to speak up by asking questions to the presenters. Some of the presenters showed good command in English. (Lec5's class, 2/6/2014)

While some of the lecturers were concerned about developing the PSTs' English language oral proficiency, other lecturers emphasised helping the PSTs improve their English language listening skills in order to indirectly help their PSTs' oral skills. Of course, in the speaking classes, the main goal would be improving the PSTs' English speaking skill, whereas in the listening classes it was developing the PSTs' listening skills. However, in the listening classes, as seen in the syllbuses and the observation field-notes, the PSTs were not only engaged in listening activities per se, but they were also encouraged to speak in English, both individually and in groups. One of the activities that was observed was PSTs doing TOEFL practice. TOEFL is an obligatory test that the PSTs have to take for graduation from the university department. With this in mind, it can be said that looking into this finding helps describe how English oral communication skills were facilitated in both listening and speaking classes in the English language teacher education program. The following section details this emphasis.

4.1.3 Improving PSTs' English language listening skills as a vehicle to improved L2 oral communication

L2 oral communication skills, as described in Chapter 2 of this present study, entails the skills to speak and listen in the L2. Improved proficiency in these two skills is seen as a single entity of the overall objectives set by the lecturers in teaching English oral communication on the English Education Program. To this end, data related to the listening skill of the PSTs is also considered relevant and important in this study. In fact, because listening skills are seen as a crucial aspect of L2 proficiency, the skills are taught as a separate coursework unit in the English Education Program.

Several lecturers who were teaching listening viewed enhanced listening skills as one of the objectives of their classes. As Lec11 put it:

Saya hanya berharap mahasiswa bisa lebih meningkatkan skill mereka, percakapannya dalam, terutama dalam mendengar ... Saya berfikir apakah ada gangguan di telinga mereka atau memang mereka ini tidak mendengar? Begitu saya tanyakan, mereka mendengar tapi tidak memahami. (Lec11: 55)

I just want to help them improve their skills, their conversation in especially in listening ... Then I think, do they have problems with hearing or do they

simply not listen? When I ask them, they do listen, but they do not understand. (Researcher's translation, Lec11: 55)

Lec11 claimed that the problem her PSTs had when listening to English language recordings was to understand what was said. That is why, as Lec8 and Lec9 reported, an emphasis should be placed on understanding oral messages. Lec9 said that having good listening skills encouraged her PSTs to respond to any statement or question in English:

Cuman saya tau itu kalau paling banyak mereka listening kalau saya ya pada akhirnya mereka tau apa yang speaker bicarakan itu, itu dulu. Apa maksud dari speaker-nya ngomong seperti itu. Lalu ketika mereka paham mereka pastinya bisa jawab. (Lec9: 45)

All I know is that I want them to understand what is being said by a speaker. That is the most important thing. Why the speaker says it. If they understand it, they will be able to answer. (Researcher's translation, Lec9: 45)

Similarly, Lec8 stated that he taught listening in order to help his PSTs develop their listening skill level by practicing listening in and out of lectures:

So my goal is I want my students to be familiar and to be what is? Can follow the subject and also they know the technique of improving their listening skill... Usually I give them some audio and then some test and then I ask them to listen at home. (Lec8: 25)

Focusing on improving students' English listening skills was explicitly stated in the lecturers' syllabuses. The document analysis revealed that the syllabus of Listening 1 unit was designed to help the PSTs "practice and increase their listening comprehension through listening for specific information, listening for details, listening for main idea, listening for recognising context and predicting" (Listening 1 syllabus, Course Description, p. 1), whereas Listening 3 aimed at allowing the PSTs "to get the idea from listening to short conversations, longer conversations, lecturers, speech, talk shows, radio and TV programs and from peers as in daily communication activity" (Listening 3 syllabus, Course Description, p. 1).

Another perceived objective in teaching English oral communication that the lecturers said they would like to address was developing the PSTs' confidence in speaking English. The following section outlines this objective.

4.1.4 PSTs develop their confidence in speaking English

The analysis of the lecturers' interview responses revealed that a few lecturers were concerned about developing their PSTs' self-confidence in using English oral communication. Lec4 perceived that improved self-confidence would encourage her PSTs to communicate orally in English. She thought that other lecturers would also emphasise this aspect, yet, very little was said about this by other lecturers. She related this confidence with PSTs' skills in transforming ideas into oral expression, as seen in the following quotes:

I think every lecturer, every teacher, you know, including myself in this subject like Speaking 1, we have in mind that we would like to really create and develop the student confidence, so they will be able to speak with confidence about, you know, how they can deliver the message, how they can transform their ideas into send oral expression. (Lec4: 2)

Another lecturer did not explicitly state that she developed the PSTs' confidence level by teaching English oral communication skills, but talked about entertaining her PSTs by teaching speaking:

If they think English is a form of communication so all they need is just to practice that no matter whether they are ... they can do that fluently or smoothly. But you know it's not about how to educate, it is about how to entertain them in teaching so they feel oh it's amazing to have English, English speaking class (Lec1: 79)

Lec1 implied that her PSTs would have the courage to use English for communication if they just practised. They would be more inclined to be engaged if the teaching was "amazing". With such positive feeling towards speaking English, the PSTs might be motivated to develop skills in using this L2 to communicate with their peers. The lecturers task in facilitating such development was to encourage the PSTs to keep practising speaking English. In the last section below, another kind of objective in teaching English oral communication was presented, namely, helping PSTs to pass the oral component of the TOEFL.

4.1.5 Helping PSTs to pass the oral component of the TOEFL

As mentioned in the previous sub-section 4.1.3, data related to improving L2 listening skill was treated as part of the findings. One of the reasons was because the English Education Program taught the skill through the listening coursework unit,

separated from the speaking. This separation shows the significance of developing the PSTs' listening skills in order to help the PSTs to become competent English language users as well as teacher candidates. Therefore, the data obtained from the lecturers who were teaching listening skill were included in this chapter.

Because taking the TOEFL (paper-based test) is mandatory for the PSTs, assisting the PSTs to pass the oral component of the TOEFL became one of the objectives of the lecturers in teaching English oral communication. Assistance was primarily given for dealing with the oral component, which also tests the PSTs' listening skills. Lec7 said that the PSTs took TOEFL listening exercises when they were in Semester 3, and confirmed the PSTs needed to do the exercises to pass the final examination of listening coursework unit:

Ya. Karena mereka at the end of this the Listening 3 mereka akan dipersiapkan ya they can prepare for follow the TOEFL test salah satu persyaratan untuk mengikuti ujian akhir. Jadi melatih sebelum mereka ikut. Sudah dipersiapkan. (Lec7: 32)

Yes. Because at the end of Listening 3, they will be prepared to, ya, they can prepare to do the TOEFL test, one requirement to attend the final exam. So, we prepare them. It is all prepared. (Researcher's translation, Lec7: 32)

In support of Lec7's views, Lec8 reported that he expected his PSTs would be able to take the TOEFL and to obtain adequate scores. This lecturer stated, as seen in the quotes below, that by taking TOEFL listening exercises, the PSTs would find "the technique to improve listening" skills in English, which was a crucial aspect in developing their oral skills. He suggested that his PSTs might try to use some expressions they learnt from the listening exercises when communicating orally in English with their peers:

So my goal is I want my students to be familiar and to be what is? Can follow the subject and also they know the technique of improving their listening skill ... So I think that they must practices. They must know how is the technique to improve listening. (Lec8: 25)

And I always told them that if you understand this simple phrases and then you practices in your daily conversation it will makes your looks like your conversation your speaking skill was good because people will saw your performance when you are speaking. So that's why they should practices by listening to this phrases to some phrases and then they can practice with their friend. (Lec8: 39)

The importance of teaching the TOEFL to PSTs as a tool to help the PSTs improve their English oral skills was mentioned by another lecturer. Lec9 said that in her class, the PSTs were not only given exercises to train their listening skills, but also to encourage them to speak up in English. She stated that in her listening classes, where the TOEFL test became part of the teaching, the improvement of other skills, such as speaking, was also addressed. She claimed that her PSTs “must be able to express what they have written” in English:

Jadi selama ini saya kalau Listening itu tidak tidak melulu di Listening. Jadi ada integrated skills. Jadi paling awal itu jadi bisa probably writing, speaking ya tapi paling ya memang walaupun utamanya itu adalah bagaimana whether ya practice their listening, tapi itu harus ada interaksi. Jadi bukan hanya mereka dengar dengar saja lalu jawab dengar jawab. Tidak. Tapi mereka harus bisa mengungkapkan apa yang mereka tulis. (Lec9: 49)

So far, my listening classes are not merely about listening. There are integrated skills in them. The skills could be probably writing, speaking, but ya ... even though the primary goal is how ... whether ya practice their listening, but there must be interaction. Therefore, they do not only listen, and then answer, listen and answer. No, but they must be able to express what they have written. (Researcher’s translation, Lec9: 49)

The notion of teaching integrated skills in the listening classes was also addressed implicitly by another lecturer. In her quote below, Lec10 suggested that she encouraged her PSTs to express their ideas orally when working on listening exercises. Despite the language her PST wanted to use, Lec10 felt that what was important in her class was to speak up:

... makanya ketika Listening Tiga ini critical listening-nya yang di ini...di bicara semua bicara semua...speak up semua apa yang mereka rasakan, apa yang mereka ini, mau campur, yang penting mereka keluarkan dulu ide-ide mereka. (Lec10: 5)

... that is why, in this Listening 3, it is the critical listening skills which ... all is said all is said ... speak up all things they feel, what they feel, in mixed languages, the most important thing they express their ideas. (Researcher’s translation, Lec10: 5)

Despite the fact that the lecturers claimed to promote dialogue to encourage the PSTs to speak in English, data from classroom observations, as seen below, revealed that the opportunity to learn or to use some ways to deal with English oral communication challenges by the PSTs was limited.

The lecturer asked one of the students to operate a cassette player to play TOEFL. When all was ready, she asked her students to complete the test individually. Then, she checked their answers. She asked them to swap their work with their peers. For feedback, the lecturer let the students share their feelings about what challenges they faced while doing the test. (Lec7's class, 22/5/2014)

The lecturer began by distributing worksheets for a listening exercise. Then she played the cassette, and asked the students to listen and choose the best answer to the questions they heard from the cassette. To check their answer, the lecturer approached the students one by one. She then played the cassette one more time to help the students find out the reasons why their answers were correct or incorrect. (Lec11's class, 14/5/2014)

These observation field-notes showed that the PSTs had a chance to work collaboratively, but the opportunities to use English remained limited. Some of the reasons are related to the language they used when working with their peers, and how the lecturers stimulated interaction in English when checking the answers to the listening exercises. The dialogue that emerged from this interaction lacked a number of OCS strategies, such as paraphrasing, asking for clarification, and using repetition, because it was confined to simple uses of questioning and answering expressions. In the subsequent paragraphs, this present study shows lecturers' responses about PSTs' English oral communication challenges.

4.2 Lecturers' perspectives of pre-service teachers' (PSTs) English oral communication challenges

Four major themes associated with PSTs' English oral communication challenges emerged from the data. These were linguistic proficiency challenges, psychological challenges, English language engagement opportunity challenges, and background knowledge challenges. Table 4.1 below provides details of the themes.

Codes	Themes
PSTs have difficulty with English grammar	Linguistic proficiency challenges
PSTs have difficulty with English intonation	
PSTs have difficulty with English pronunciation	
PSTs lack adequate English vocabulary	

PSTs lack confidence PSTs are not interested in participating PSTs face peer pressure	Psychological challenges
PSTs lack exposure to English	English language engagement opportunity challenges
PSTs cannot talk much about a particular topic	Background knowledge challenges

Table 8 Lecturers' perspectives of PSTs' English oral communication challenges

In the following sections the findings are presented. Quotes from both the lectures and the PSTs are included as evidence to support each finding. These quotes follow interpretations of the findings. At the end of each quote, there is a sign in brackets, which details the lecturer who owns the quote and the page of the interview transcript from which the quote is taken. English translations are given following each quote written in Indonesian (in italics). In addition to these quotes, relevant field-work notes are also used as evidence to support some of the findings.

4.2.1 Linguistic proficiency challenges

Linguistic proficiency challenges refer to some aspects of language skills, such as grammar, pronunciation, and vocabulary that the PSTs found difficult to improve. Lecturer 1 (Lec1) argued that English grammar and intonation were challenging for the PSTs, and she perceived that it was caused by a lack of practice:

Then maybe half of them they are eager to talk but you know we can see that their problems with grammar, they have problem with intonation because lack of practices. (Lec1: 58)

With regard to English pronunciation, Lec5 and Lec7 said that the PSTs found this challenging. According to Lec7, the reason why it was challenging was because the PSTs' local languages featured pronunciation forms which influenced the way the PSTs pronounced words in the L2. Consequently, this lecturer argued, many of the PSTs strived to articulate words in English appropriately on the basis of what they had been learning in the classroom.

Kadang di dalam pengucapan dalam Bahasa Inggris dari mahasiswa itu pengaruh disitu adalah bahasa ibu mereka. Iya. Kadang kalau dia berasal dari Makassar pengaruh juga bahasa ibunya ya dari cara pengucapannya. Jadi apa yang mereka dengar walaupun berulang-ulang kadang masih juga tetap begitu. (Lec7: 14)

Sometimes what influences the students' pronunciation is their mother tongue. Yes. Sometimes, if they come from Makassar, Makassar language may affect their pronunciation. So, what they listen to, even though they listen to it repeatedly, their pronunciation remain the same. (Researcher's translation, Lec7: 14)

In addition to English pronunciation, some lecturers reported that a lack of vocabulary was also an oral communication challenge for the PSTs. Lec3, for instance, said:

Oh ya mostly because they have lack of vocabulary. That's the major problems that we have in speaking class. (Lec3: 53)

Lec11 added that a lack of vocabulary can prevent the PSTs from understanding messages in English:

Saya berusaha untuk memberitahu mereka comprehend, pemahamannya, dan vocab-nya itu harus banyak. Otomatis kalau mereka tidak banyak vocab, kosa katanya yang dikuasai, berarti mereka tidak bisa mengerti apa yang diucapkan orang. (Lec11: 62)

I try to tell them to comprehend, their understanding, and to have a lot of vocabulary. Of course, if they lack vocabulary, vocabulary to master, it means that they cannot understand what other people say. (Researcher's translation, Lec11: 62)

One of the implications of having limited English vocabulary, according to Lec8, was the inability to express ideas orally in English:

I think it because some students were found difficulties in expressing their idea in English maybe because of their lack of vocabulary. That's why I ask them if you are found difficulties to say it in English you may use Indonesia or maybe try to mix with the English language. (Lec8: 44)

These lecturers' views were confirmed by the PSTs. PST4, for instance, described how he was still unable to improve his grammar, which in turn affected his accuracy in English:

Mungkin skill saya dalam...yang paling yang paling susah atau sangat sulit bagi saya itu dalam memparalelkan kata-kata dalam berbahasa Inggris. Di grammar (XXX) masih goyang. Grammar saya belum stabil. (PST4: 21)

Maybe the skill I have in ... what I found to be the most difficult in structuring words in English is grammar. (XXX) My grammar has not improved. It is not stable yet. (Researcher's translation, PST4: 21)

In addition, PST7 reported that what she perceived to be a discouraging factor in speaking English was having limited English vocabulary. She assumed that people

with limited L2 vocabulary, like her, would find difficulties to express themselves in the L2, and this might make them fearful about speaking up:

Kurang penguasaan vocab. Itu yang paling bikin orang takut ngomong bahasa Inggris itu karena vocab masih limited, masih terbatas sekali. Jadi orang masih...bahasa Inggris apa, bahasa Inggris ini apa, bahasa Inggris ini apa. (PST7: 41)

Lack of vocabulary mastery. That is what makes people afraid to speak English because of limited vocabulary. So, people still ... what is this in English, what is that in English. (Researcher's translation, PST7: 41)

PST2 added that having limited vocabulary and poor pronunciation in English language was a disadvantage for him and could result in poor English oral skills. He suggested that if he had enough English vocabulary, he would be able to "enrich" his sentences. He would be able to express himself in the language he was learning:

Yes, yes, besides the...how to pronounce it and also our vocabularies because I realise that I still have the limitation of vocabularies and I also realise that if I don't have enough vocabularies, I couldn't enrich my sentence to say what I mean, like that. Yes. (PST2: 28)

Data taken from the classroom observations provided meaningful insights that corroborated interview responses. Field-notes from the observations revealed that the classroom situation played a key role in stimulating the PSTs to speak English. A lecturer's choice of language when teaching may influence the PSTs' choice of language when interacting in the classroom. When more focus is given by the lecturers to the use of the first language, the less proficient PSTs avoided speaking the second language they were learning. In one listening class that was observed, for instance, the majority of the PSTs, when asked to respond to the lecturer's questions, chose to use Indonesian language to communicate. One of the reasons was that the lecturer chose to code-switch from English to Indonesian, and this code-switch encouraged the PSTs to speak in their first language when responding to the lecturer's questions. This is illustrated in the field-notes below.

The lecturer started the class by doing an ice breaker. She then introduced the topic for today's lecture. After that, she played a cassette. It's TOEFL exercises. In a few minutes later, she checked the student's answers. She also asked the students to share any challenges they faced while working on the exercises. This lecturer used both English and Indonesian language at this stage. As she did code switch, the majority of the students decided on using Bahasa Indonesia to respond to her questions. (Lec7's class, 22/5/2014)

A further analysis of the data presented in this section showed that the English oral communication challenges associated with the PSTs in and out of lectures also impacted on psychological aspects of their learning.

4.2.2 Psychological challenges

Psychological challenges refer to challenges such as PSTs' lack of confidence, lack of interest in participating, and peer pressure. With regard to confidence, Lec4 said that her PSTs became nervous, particularly when speaking in L2, because they were not confident. This feeling, she argued, put the PSTs in the group of what she called "weak students", which called for attention by the lecturers. This lecturer implied that confidence play a key role in learning an L2, especially in L2 oral communication:

Some are so nervous because lack of confidence. So we have to work hard in terms of paying attention also to the weak students. (Lec4: 5)

Lec9 asserted that a lack of confidence was also the main challenge that the PSTs experienced in the classroom. She contended that the reason for this was PSTs' personalities. Some PSTs felt shy about expressing ideas, whereas others did not understand what to say:

Tantangan utama pada dasarnya mereka malu ya. Ada yang kembali ke karakteristik mahasiswa itu sebenarnya. Ada yang memang dia tau tapi dia malu mengungkapkan. Lalu, ada yang memang benar-benar tidak paham. (Lec9: 61)

The main challenge is they are shy. Actually it depends on the students' characteristics. There are some students who know something, but they feel shy to say it. Then, there are some students who do not understand. (Researcher's translation, Lec9: 61)

This view was supported by Lec11, who said that the PSTs were shy about using English to communicate, because they feared making mistakes:

Mereka malu untuk memprakteknya, mempraktekkan, malu untuk berbahasa Inggris, malu untuk dan takut berbuat salah. (Lec11: 67)

They feel shy to practice it, to practice speaking English. They feel shy and are afraid of making mistakes. (Researcher's translation, Lec11: 67)

Responses from Lec9 and Lec11 indicated that PSTs might be reluctant to speak in L2 not only because they feared making mistakes, but also because support from

peers was limited. When such support exists, opportunities to engage in English oral interaction, where each PST takes turn in exchanging messages and, thus, practises speaking in L2, may be present. To this end, some PSTs might have felt that they were being linguistically judged in speaking English because other PSTs chose not to use English for various reasons. That is why, because such opportunities are rare, some PSTs possibly felt demotivated to remain active in speaking English, although the opportunities to interact orally with the lecturers were available.

Another psychological challenge that the lecturers reported was PSTs having a lack of interest in participating in the classroom activities. Lec1 stated that some of the PSTs “come into the department because of the parents’ needs and they are not interested in English” (Lec1: 58). This was confirmed by Lec9 who said that some of her PSTs “cuek bebek di kelas” [show no concern for what happens in the classroom] (Lec9: 61). The reasons why this happens could vary, but such behaviours could be triggered by PSTs’ level of linguistic proficiency and affective factors (e.g. motives to enrol into the English Education Program). In fact, some of the PSTs revealed a preference for pursuing careers in government jobs rather than teaching, as seen in the Lec11’s responses below. This could shape their motivation for engaging in English oral communication:

Sebenarnya sih kalau untuk daerah Gorontalo yang paling utama mereka harus PNS dulu. Itu yang terpaut dalam dalam otak mereka. (Lec11: 69)

Actually, in Gorontalo city, the main goal is to become government employees. That is what they have in mind. (Researcher’s translation, Lec11: 69)

The other psychological challenge that emerged from the interviews was PSTs facing peer pressure from other PSTs in the course as well as peers generally. Lec3 implied that peer pressure is a typical phenomenon in language classrooms in Indonesia. Thus, asking PSTs, especially those in their first year of study on the English Education program, to switch into English when communicating in the classroom would in fact discourage them from using the language. Peer pressure, such as the fear of being linguistically judged by others while speaking in L2 was confronting for the PSTs and caused them to shy away from speaking English. Lec3 asserted:

So, we cannot impose them to speak English all the time. They won’t speak. They won’t. Trust me. There is a there is a peer pressure in Indonesia in general. A peer pressure that make them don’t wanna speak. (Lec3: 56)

Lec4, in support of Lec3, implied that she recognised the emergence of this pressure among the PSTs and that the source of the embarrassment was from PSTs' anxiety about making mistakes while speaking English. As she put it:

And I always say to them, don't be worry about that because English is not your native language. English is the foreign language of us. So you have to keep in mind that trying is the most important and then after that you can learn through the process of the mistakes you make. (Lec4: 2)

Lec8 added that fear of looking linguistically incompetent in front of peers caused PSTs to be reluctant to speak. Lec8 stated that making mistakes while speaking English could trigger stress in to PSTs:

But sometimes we are found difficulties because they are reluctant or maybe they are afraid or maybe they anxiety to use English because they worried if they are wrong maybe some of their friends will laugh at their pronunciation. (Lec8: 44)

These lecturers' views were supported by the PSTs' views. With regard to the lack of confidence issue, PST3 reported that difficulties in expressing ideas and feeling under confident were common for her when speaking English, as seen in the following excerpt. 'Ab' is the initial of the researcher, and the number following it is the turn-taking response:

PST42 : Problems, it's hard for me to...
Ab43 : Express?
PST43 : Yes. And sometimes I am feel not, what is?
Ab44 : Confident.
PST45 : Yes.

PST5 also stated that the major problem she had when communicating in English was her confidence in front of her classmates. She attributed her under-confident feeling with a lack of vocabulary which triggered silence while speaking in English. She said:

Of course improve my speaking skill and I think my biggest problem in English is my confidence. It's so hard to be relaxed standing in front of the class and say whatever you want to say but it's just it's usually stuck in some words that couldn't find the vocabulary or something like that. (PST5: 28)

With regard to the peer pressure issue, PST1 contended that the stress that many PSTs felt was caused by the inability to pronounce some English words in front of other peers and the influence of the linguistic features of their local languages on their use of English:

Disini khan rata-rata berbicaranya English tapi ke Indo-Indo-an, Sir. And then yang ini benar-benar bukan Indo lagi tapi kedaerahan bawa ama logat-logatnya daerahnya, trus pengucapannya salah-salah untuk bahasanya yang seharusnya gimana dibuat gimana. So it's not familiar for other student. So they make me, make them laugh. (PST1: 53)

Here, many people speak Indonesian English, Sir. And then it is not only the Indonesian language that matters, but also their vernacular languages and accents. Also, their pronunciation is often wrong. So it's not familiar for other students. So they make me, make them laugh. (Researcher's translation, PST1: 53)

PST3 added that she often felt embarrassed when her peers laughed at her mispronunciation. Apparently, a talk like the one she gave in the classroom was a source of concern. Below is an interview quote with this PST. The sentence in brackets is the researcher's translation.

Ab54 : What makes you embarrassed?

PST54 : Ketika salah mengucapkan, salah kata, salah penempatan kata when I spoke in front of class. [When mispronouncing, wrong words, misplacing words when I spoke in front of class]

Ab55 : But the audience may not do something.

PST55 : They laugh.

Alongside the PSTs experiencing issues related to psychological challenges, lecturers also perceived that the PSTs experienced some challenges in English oral communication because of their lack of English language engagement opportunity. This is outlined in the following section.

4.2.3 English language engagement opportunity challenges

English language engagement can be defined as PSTs involvement in any kind of activities that expose them to the use of English. Lack of English language engagement, especially in the form of speaking English with peers and lecturers, is perceived by the lecturers as an issue for the PSTs. Responses from lecturers showed that their PSTs had limited exposure to English language users both in and outside the classroom because of the dominant use of L1. Lec4 related the lack of English exposure to limited opportunities to practise the language, even in the university department:

Of course you realise in our environment there are no much people talk in English, but if you don't start by yourself, who will you be waiting for? ... So yeah one is about the exposure of English is little. (Lec4: 10)

In line with Lec4, Lec5 asserted that the classroom situation at the university department did not support the PSTs using English in oral communication. This lecturer implied that he had difficulties in motivating his PSTs to practise speaking English in the classroom because of the large number of the PSTs in any one class and the limited teaching time. Lec5's responses indicated at least two things with regard to his teaching practises. First, his PSTs engaged mostly in one-way oral communication, where interaction from peers that promotes dialogue might be limited. Second, the lecturer believed that the frequency of using L2 during classroom activities that involve speaking determines the success of learning to communicate in L2:

It's only about a hundred minutes and then there are twenty or even more students in the class. So if we calculate, so dealing with a hundred minutes and thirty students or let just say twenty. It means that students only speak five minutes. So in one week they only have a chance to speak English five minutes and I think it less than enough for them to be better in English. (Lec5: 28)

Lec8 added that instead of talking in L2 during group work, his PSTs talked in L1. He realised the importance of speaking in L2 when engaging in group work, which could be promoting dialogue with peers where they could develop their English fluency and accuracy, as well as improve their confidence:

Ya usually they use Indonesian language ... And maybe it is important also that in the class they will always use English language. (Lec8:44)

Lec11 reported that the reason why many of her PSTs preferred using Indonesian language when participating in classroom activities was because they simply did not understand what they heard in English. This could be attributed to a lack of adequate English vocabulary and limited proficiency in English language listening skills:

Sometimes they speak in English, but the other groups sometimes in using Indonesian language. They ... so I ask for them, why you use in Indonesian language? We don't understand, ma'am. (Lec11: 57)

Challenges with the use of L1 (Indonesian language) were confirmed by the PSTs. PST5, for example, said:

... kalau inginnya saya sih full English itu penting pembelajaran dalam full English, not mixed or in Bahasa karena kita khan kita ini sudah berada dalam program pendidikan bahasa Inggris. Kita bukan lagi jurusan lain yang mesti ditranslate artinya begini untuk ngerti apa tujuannya belajar bahasa Inggris. (PST5: 33)

... For me, I think it is important to carry out a lesson in English, not mixed or in Indonesian language because we are doing an English Education program. We are not like students from other departments who need translation, who want to know why they should learn English. (Researcher's translation, PST5: 33)

PST2 added that in the classroom, the use of English was determined by the lecturers. He implied that when a lecturer chose to speak English as the main language of instruction, his peers and he would also use English, and vice versa with the use of Indonesian. Yet, this PST also argued that code switching in English and Indonesian should be tolerated:

For my experience, it based on our lecture ya. Kadang dalam [Sometimes in] during our class, we have to speak full English ya but sometimes we also don't have to speak full English, maybe we can say in Bahasa or in English, it's okay. (PST2: 43)

PST2 also related this lack of exposure to English in the classroom to the context outside the classroom. He stated that his opportunities to practise speaking English with his classmates were limited, particularly as he would not be spending much time on the campus in the following semesters. What he did to compensate for this situation was to teach English in an English language course in his workplace where he had the opportunity to develop his own speaking skills. The quote below demonstrates PST2's views:

PST53 : ... *Dan kalau yang untuk sekarang itu saya merasa kalau untuk kesempatan dengan teman-teman untuk berbicara bahasa Inggris itu udah ngga terlalu seperti yang seperti lalu-lalulah.*

And for now I feel that the chance to speak English with my friends is not like what it was used to be in the past. (Researcher's translation)

Ab54 : *Kenapa?*

Why? (Researcher's translation)

PST54: *Ya karena waktu saya dikampus itu udah terlalu ngga terlalu banyaklah. Jadi untuk melatih kecakapan saya itu sebagian besar saya gunakan ditempat ngajar saya saat ini, seperti itu.*

Ya because I don't have much time to spend at campus now. So, to drill my skill, I practice it when I teach at my workplace. (Researcher's translation)

PST4, on the other hand, had a slightly different view to PST2. He said that he had enough chances to utilise his speaking skills, but not his listening skills. This PST showed that he was concerned about how to deal with difficult situations in which English fluency and accuracy were needed. He implied that he might need some

strategies that he could use to maintain involvement when communicating orally in L2:

Kalau speaking iya, mungkin listening belum. Belum saya dapat artinya belum klop dibenak saya tentang bagaimana sih cara ber-listening dengan baik, cara bagaimana mengantisipasi ketika speaker yang berhadapan dengan kita itu cepat atau narrative speakernya terlalu, apa namanya, pronouncenya sangat beda dengan apa yang kita pernah kita ketahui. (PST4: 29)

If it is speaking, yes, but not with listening. I have not figured out yet the way to listen effectively, the way to anticipate when the speaker speaks fast or the native speakers' pronunciation varies greatly from the ones we understand. (Researcher's translation, PST4: 29)

Overall, the lecturers believed that many of their PSTs refrained from using English because their surroundings did not stimulate the use of English for interaction. Other lecturers related this constraint to the issue of limited background knowledge about topics used in classroom discussions. This issue is presented in section 4.2.4 below.

4.2.4 Background knowledge challenges

Background knowledge refers to any general information that the PSTs have and use when talking about a given particular topic, especially in the classroom context. This present study found that the challenges related to lack of background knowledge were repeatedly identified by lecturers as affecting the PSTs' oral communication in English. Lec5 perceived that unless PSTs had sufficient knowledge about a particular given topic, they could not make comments using English:

But some of their limitations is dealing with their general knowledge ... So the students can get to speak more if they supported enough by having brought general knowledge. (Lec5: 7)

These views about such constraints were supported by Lec6 who also claimed that her PSTs lacked interest in seeking additional information from television or other printed media. As a result, Lec6 argued, her PSTs were unable to maximise their use of English during classroom discussions because they lacked information to explore. Lec6 believed that watching television or reading news kept her PSTs updated with issues that were happening, and this helped them participate actively in the discussions:

... because especially in Gorontalo they don't have like the culture of searching or reading or anything else, because when I come to my class,

when I ask them to speak, for example, in speaking class, because when I ask them to discuss ... related to the issue happened in recent time, they can't do much because they don't watch TV, especially for TV programs or they don't read news. So it's really hard for me. (Lec6: 22)

PST5 confirmed these lecturers' views. She did not only say that feeling confident when speaking English was difficult, but also said that limited background knowledge of the topic of discussion was a challenge for her. She argued that the background knowledge a person had could affect the way the person spoke in English:

Percaya diri itu penting dan itu yang menjadi masalah saya selama ini. Saya kurang percaya diri, terus knowledge mungkin. Pengetahuan yang kita miliki juga mempengaruhi cara kita berbicara dalam bahasa Inggris. (PST5: 44)

Feeling confidence is important and this is what troubles me all the time. I feel that I have a lack of confidence and maybe knowledge. The knowledge we have also affects the way we speak in English. (Researcher's translation, PST5: 44)

To deal with all the challenges mentioned here and in the earlier sections, the lecturers reported that they used a number of techniques and strategies. These are described in the following section.

4.3 Techniques and strategies used by lecturers to cope with PSTs' English oral communication challenges

The data showed that there were five teaching techniques and strategies which best described how the lecturers dealt with PSTs' English oral communication challenges. These were setting up classroom activities, setting up group work, tolerating and encouraging the use of L1, encouraging independent learning, and using strategies for extending speaking turns (asking for clarification and memorising vocabulary). The subsequent sections describe each of these techniques.

Codes	Teaching techniques and strategies
Using games	Setting up classroom activities
Asking PSTs to do the Show and Tell activity	Setting up group work
Asking PSTs to work in pairs/groups	Tolerating and encouraging the use of L1
Allowing PSTs to use Bahasa Indonesia	

Encouraging PSTs to learn independently	Encouraging independent learning
Asking for clarification Helping PSTs to improve vocabulary mastery	Using strategies for extending speaking turns (asking for clarification and memorising vocabulary)

Table 9 Teaching techniques and strategies used by lecturers to cope with the PSTs' English oral communication challenges

4.3.1 Setting up classroom activities

Games and Show and Tell type activities were seen by the lecturers as useful in coping with difficulties related to English oral communication engagement in the classroom. Lec1, for instance, said that she would use games, conducted in groups or in pairs, to encourage her PSTs to use English. In fact, she used games to monitor her PSTs' speaking skill development and to encourage low proficient PSTs to speak English. To do this, Lec1 drew on group or pair work, where low proficient PSTs could find help from their peers to overcome certain oral communication challenges they might encounter:

So I have so many ways how to attract the lower students to be involved in activities. So I have just like making groups, do in pairs. We do a lot of games. So sometimes we have method in teaching but then while doing that we should see their progress by giving them activities and the activities one of them is gaming. (Lec1: 68)

Likewise, Lec9 considered games as an appropriate option to stimulate the PSTs' classroom English oral interaction. She said that a game, called Talking Stick, encouraged PSTs to speak up before their peers:

Membuat siswa atau sorry membuat mahasiswa tertarik atau membuat mahasiswa berinteraksi dengan baik dalam kelas itu ada istilahnya kayak kemarin saya pakai ada yang Talking Stick. Jadi mahasiswa bergiliran untuk bicara di depan. (Lec9: 63)

In order to help students become interested or to make them interact effectively in the classroom, I use Talking Stick. So, students take turns in speaking before their peers. (Researcher's translation, Lec9: 63)

For some lecturers, the Show and Tell activity was an alternative to a game. In this activity, the PSTs talked about items of interest to them. They were trained to develop skills in giving oral presentation. As Lec2 put it:

Like Show and Tell. So, they will bring a thing that they thought that it is favourable or adorable or something like that, but they don't have to show to their friends before the class started. So, when they perform the class they will show it surprisingly then they will explain why they took this thing. Something like that. (Lec2: 31)

The use of this activity was confirmed by PST7. This PST pointed out that describing memorable belongings was one of the classroom activities in the speaking class, as seen in the following excerpt.

Ab50 : *Kalau dimata kuliah Speaking, can you tell me about the activities?*

If in the speaking class, can you tell me about the activities? (Researcher's translation)

PST50 : *Kemarin menyanyi.*

We sang a song (Researcher's translation)

Ab51 : *Oh menyanyi?*

Oh, singing? (Researcher's translation)

PST51 : *Ya. Terus waktu itu show and tell barang yang memorable. Dibawa terus dijelaskan, kayak gitu sih paling. Terus tiap speaking kan pasti ada ada topik-topik yang bakal jadi bahan untuk speaking.*

Yes. We did the show and tell about a memorable belonging. We bring and explain it, that is what we do. Also, there are various topics to discuss in the speaking class (Researcher's translation)

While this activity stimulates individual participation, other activities emphasised the importance of working in groups to facilitate improvement in L2 oral communication.

4.3.2 Setting up group work

Group work, in the context of this present study, can be defined as activities that involve two or more persons working together in and out of the classroom. In the present study, some lecturers reported that they used group work to encourage the PSTs to use English orally. For example, Lec4 reported that working with peers provided an opportunity to improve confidence level in speaking English. This lecturer perceived that for L2 beginner level learners to speak L2, speaking with peers could be much safer and more comfortable than with lecturers:

So for example if they choose the theme best friend, two of them will work together. ... So this is, you know, in my understanding that we can accommodate their worry about to how to speak English in, you know, in the first time by themselves in their beginning level like that. (Lec4: 3)

Lec2 added that working in groups helped the PSTs to share classroom activities based on their interests and level of proficiency. She implied that her PSTs took on different parts of the group activity depending upon their English language proficiency level:

Not really but because they work in groups so other students will fill it. So *biasanya mereka sudah bagi bagi tugas, 'oh saya akan mengambil untuk opening-nya tapi bukan berarti saya tidak tau body-nya', kemudian 'saya nanti closing-nya'*. (Lec2:33)

Not really but because they work in groups so other students will fill it. So, they usually share tasks, 'Oh I will do the opening' but this does not mean that he or she does not know the content, and 'I will do the closing'. (Lec2: 33)

Similarly, Lec8 who was teaching listening, perceived that group work helped the PSTs in the listening classes, which in turn aided their English oral communication skills. This lecturer suggested that working in groups provided an opportunity for the PSTs to identify which areas of their learning needed improvement:

Usually they found difficulties. But if they do it in groups they can ask each other. So they will know what is his or her ... what is it? Lack or maybe what is? Weaknesses from the audio so they can collect their group's opinion and then write down the answer. (Lec8: 43)

This finding was corroborated in the classroom observations of speaking and listening classes. The following field-notes taken from Lec8 (listening) and Lec3's (speaking) classes are examples of how the group work was organised in order to promote dialogue.

There were about 22 students attending today's class. They were seating in the computer laboratory. The lecturer asked them to match story in the diary with the story they heard from the recording. In groups, the students completed the task. Initially, they looked for the answers individually, then they shared and compared the answers with their group members. (Lec8's class, 12/5/2014)

The topic for today's lesson was giving direction. After explaining some useful expressions about giving direction, the lecturer put the students in groups. The students were asked to play a game. They must help one member of their group to get to a particular place by giving direction. (Lec3's class, 12/5/2014)

With regard to completing group activities, lecturers suggested that it is important to take into account the use of L1 for the PSTs. Exclusive use of L2 (English) during

classroom activities completion discouraged some PSTs from participating because of their L2 linguistic gap and psychological challenges (e.g. peer pressure) they might encounter. The subsequent section describes the use of L1 in the classroom context as a teaching strategy used by lecturers.

4.3.3 Tolerating and encouraging the use of L1

Lecturers agreed that using L1 with the PSTs was helpful in tackling L2 oral communication challenges in their classrooms. Lec3, for example, said that preventing the PSTs from using Indonesian in the classroom and promoting English only could discourage the PSTs from using English:

Well to me that's fine. This is Speaking 1, you know. Because they are not born with the language. They are here to learn, right? If you force them to speak English all the time, they won't speak. They won't speak at all. So first thing that you have to do, let them speak. (Lec3: 56)

PSTs, especially those at the beginner level, might need to have as many opportunities as they can to express themselves orally in either L2 or L1. Lecturers at this level, according to Lec3, were responsible for ensuring that PSTs had the opportunities for supported L2 oral communication. PSTs might then develop a positive attitude towards any given English speaking activity and actively participate in the activity completion, which, in the long term, might help them improve their English oral communication skills.

This view was shared by Lec10. She suggested that just to speak in any language rather than forcing them to speak in English all the time helped reduce the PSTs' levels of anxiety about the oral communication medium:

Tidak. Tidak. Saya sesuai kemampuan mereka. Jadi jangan sampai mereka karena ini kan kelas Listening, bukan kelas Speaking. Jadi saya mengambil persuasive, secara persuasive, jangan sampai mereka merasa tertekan di dalam kelas sehingga tidak bisa mengerjakan apa-apa. (Lec10: 5)

No. No. For me, it depends on their ability. So, I don't want them to feel oppressed because this is listening class, not speaking. So, I approach the students persuasively so that they won't feel the pressure that might not enable them to do anything in the classroom. (Researcher's translation, Lec10: 5)

Lec10 implied that in the listening class the use of L1 to some extent was tolerable because the aims of the lesson were to improve the PSTs' listening skills, not speaking skills. However, this lecturer also encouraged her PSTs to speak in the L2 as much as they could in listening skills classes. As she put it:

Mix. Karena ada mahasiswa yang ketika ditanya pake bahasa Indo, pake bahasa apa ma'am, bahasa Inggris atau bahasa Indonesia? Saya bilang coba pakai bahasa Inggris. Tidak bisa mengeluarkan ide-idenya. (Lec10: 14)

Mixed. Because when there are students who asked, "what language to use, ma'am? English or Indonesian?" I said, "try to use English". They cannot express their ideas. (researcher's translation, Lec10: 14)

The use of L1 during classroom interaction was noticeable in some of the lecturers' classes, particularly in the listening classes, as seen in the following excerpts from observation field-notes. The lecturers used Indonesian language along with English to help their PSTs understand classroom instructions. Despite the use of L1 and code-switching, dialogue which could promote rapport between the lecturers and their PSTs was present. Hence, improvement in the PSTs' level of confidence in using L2 could be fostered.

The lecturer started the class by doing an ice breaker. She then introduced the topic for today's lecture. After that, she played a cassette. It's TOEFL exercises. In a few minutes later, the lecturer checked the student's answers. She also asked the students to share any challenges they faced while working on the exercises. The lecturer used both English and Indonesian at this stage. As the lecturer did code switch, dialogs between the lecturers and the students occurred although the students used Indonesian to respond to the lecturers' questions. (Lec7' class, 22/5/2014)

The lecturer introduced the researcher, then asked the students if they had done their homework. Apparently, the majority of the students had not done it yet because they did not get the worksheet for some reasons. The lecturer continued to ask the students to listen to TOEFL exercises and to work on them. After that, she checked the students' answers by asking them questions in English and Indonesian. As the lecturer used Indonesian, many of the students participated by responding in Indonesian. (Lec10's class, 25/5/2014)

While some lecturers felt that the use of L1 remains important in the classroom, others believed that it is also important to nurture the PSTs' ability to use L2 in and out of the classroom. The next section, encouraging independent learning, elaborates upon this.

4.3.4 Encouraging independent learning

Independent learning requires learners to be in control of their own learning. In this instance, some lecturers saw this as helpful for improving PSTs' ability to use English for wider purposes. Lec4 suggested that promoting independent learning may help lecturers to motivate PSTs in their language learning. Lec4 perceived that lecturers needed to facilitate PSTs' independent learning in the classroom if they wanted to see their PSTs' language learning improve. It was important for lecturers to appreciate or acknowledge PSTs efforts to learn independently:

... we develop their autonomy learning, their independent learning, but we can't just let them by themselves. We have to be there. Not to help them. No. But to facilitate what they have learnt, what they have practiced, what they have, you know, gone through the process in order to appreciate like it's a kind of appreciation of their preparation. And I found that's very useful in building up more, in developing more and in motivating them more, you know, about their English, interest. (Lec4: 21)

In support of Lec4's views, Lec8, who was teaching listening classes, reported that one way of PSTs engaging in independent learning was by accessing online information:

Jadi saya tekankan kepada mereka jangan cuma materi yang dapat dari dosen hanya itu yang dipelajari. Usahakan anda sendiri yang mencari melalui internet atau melalui media lainnya misalnya ada juga kan koran dalam bahasa Inggris. Mereka bisa baca. Jadi mereka bisa melatih bahasa Inggris itu melalui baca koran yang dalam bahasa Inggris, magazine bisa atau bisa dari TV atau bisa ya apa saja untuk mereka bisa ini. (Lec8: 75)

Therefore, I encourage them not to rely solely on the information obtained from the lecturers. They have to seek additional information from the Internet or other media, such as newspaper written in English. They can read it. Thus, they can practice their English by accessing the English newspaper, magazines, TV programs, or anything else that can help them to do so. (Researcher's translation, Lec8: 75)

Lec8 perceived that asking the PSTs to practise using English outside the classroom was helpful in developing their ability in test taking competence, such as the mandatory TOEFL test taken before graduation. The TOEFL features various types of exercises that might be helpful in developing the PSTs' listening skill level independently, which in turn aid the PSTs' experience in English oral communication. Through the TOEFL exercises, the PSTs could learn various L2

useful expressions in different communicative situations and develop their L2 vocabulary capacity for carrying out L2 oral interaction:

So usually in my class I usually tell them to because listening related to the skill of personal skill so they need practices more. Usually I give them some audio and then some test and then I ask them to listen at home. They practices by theirselves at home. (Lec8: 25)

Data from the interviews with the PSTs revealed that, out-of-classroom activities could help PSTs improve their use of English for oral communication. PST1, for example, said that practicing speaking with peers and using the language laboratory and accessing its facilities could help her find ways to improve her English oral proficiency level. Unfortunately, the English speaking environment of the English Education Program is not conducive to improved English language oral proficiency according to one PST:

Basically will take this, speaking, speaking course, individually I want to make my speaking skill fluently but how come if our friends and then the lecturer itself do not use English in the class, so ... and the facilities like language laboratory and the...yes audiovisual not *mendukung* (support) to our ability. Just it. (PST1: 36)

PST7 reported that she chose reading as an alternative out-of-classroom activity to improve her vocabulary, which she believed to be an influential aspect in improved L2 oral communication:

Baca artikel atau buku bahasa Inggris. Baru kan ada kata-kata yang tidak dimengerti. Jadi itu yang cari arti baru baca-baca ulang, akhirnya bisa. (PST7: 42)

Read articles or books in English. There must be words that I don't understand. So, I look for the meaning, read them several times until I can understand them. (Researcher's translation, PST7: 42)

Learning independently might not directly provide the PSTs with a practical solution to dealing with their English oral communication challenges. However, some lecturers suggested that English oral communication could be developed by extending their speaking turns, a topic that is discussed in the following section.

4.3.5 Using strategies for extending speaking turns

Lecturers reported that in order to help their PSTs improve their English oral communication skills, they incorporated certain teaching strategies that allowed the

PSTs to extend their speaking turns. This helped the PSTs find ways to maintain their involvement in L2 communicative situations. The strategies the lecturers claimed to teach or encourage were asking for clarification and memorising a set of vocabulary.

4.3.5.1 Asking for clarification

Asking for clarification, in this present study, means that interlocutors ask for repetition or further explanation while interacting orally in an L2. Lec6 and Lec7 used this technique to help their PSTs maintain involvement in English oral communication. As Lec6 put it:

But you know, when they say mam, mam, I really want to speak but I don't know, I don't how to express the idea. Sometimes I ask you, what do you mean or what do you want to say or sometimes I help them by giving them clues or...so they can speak or if they don't know sometimes when they are speaking and they got stuck, they don't how to express the ideas, so I ask what they want to say. So I give them the clues and then they will express that by themselves. (Lec6: 40)

According to Lec6, giving clues helps her PSTs continue speaking English. This assistance helps the PSTs to deal with linguistic difficulties (e.g. lack of vocabulary and grammar) or background knowledge. Lec6 implied that this direct assistance by lecturers was important for PSTs to keep their involvement in L2 interaction. Asking questions to elicit PSTs' intended messages was one way to assist or to scaffold the PSTs.

Lec7 also said that when she found her PSTs had stopped talking, she asked them to clarify what they had been talking about. By asking what her PSTs wanted to say, this lecturer believed that her PSTs would be able to continue speaking in the L2:

Ya, I help to them. Jadi langsung membantu mereka dengan menanyakan apa maksud mereka. What do you mean about you want to say that? Oh they can say in Indonesia. Ah baru saya katakan, oh it means that, oh ya I forgot the words. (Lec7:54)

Yes, I help to them. So I immediately ask them what they want to say. What do you mean about you want to say that? Oh they can say in Indonesia. Then, I say, oh it means that, oh ya I forgot the words. (Lec7:54, researcher's translation)

During the classroom observations, the use of the 'asking for clarification' strategy was noticeable. In Lec7's class, for example, Lec7 used 'asking for clarification'

strategy when checking her PSTs' answers to TOEFL exercises, particularly when she found her PSTs had difficulties in giving correct answers orally. By checking her PSTs responses using Indonesian and English, Lec7 aimed to maintain dialogue with her PSTs in order to engage them in L2 oral communication. This is further explained in the observation excerpt below:

The lecturer checked the students' answers. She approached each group and asked the students in the group deliberately about the correct answers to the questions they heard from the recordings. As some students in the groups were doubtful when giving answers, she tried to elicit what they actually wanted to say using both English and Indonesian.
(Lec 7's class, 22/5/2015)

Lecturers also perceived that a lack of vocabulary was one of the reasons why communicating orally in L2 was often not as successful as it could be for PSTs. Findings related to memorising a set of vocabulary are presented below.

4.3.5.2 Memorising vocabulary

Memorising vocabulary, as a strategy to help L2 learners survive in English oral communication, was explicitly mentioned by Lec11. This lecturer perceived that unless the PSTs memorise vocabulary, they might have difficulties understanding what other people say in English. For this lecturer, having adequate vocabulary capacity was a key aspect to improve L2 oral communication skills:

Saya berusaha untuk memberitahu mereka comprehend, pemahamannya, dan vocab-nya itu harus banyak. Otomatis kalau mereka tidak banyak vocab, kosa katanya yang dikuasai, berarti mereka tidak bisa mengerti apa yang diucapkan orang. (Lec11: 62)

I try to tell them to improve their comprehension and vocabulary mastery. Of course, if they lack L2 vocabulary, L2 vocabulary to master, they can find it difficult to understand what other people say. (Researcher's translation, Lec11: 62)

This was corroborated in Lec11's class. The following excerpt illustrates Lec11's use of this strategy.

When all the students received the handouts, they started working on the exercises. At this stage, they did the exercises in groups. Later on, the lecturer checked their answers. She began asking the groups at the back row to share their answers to the exercises they had heard from the recordings. After all groups gave answers, she wrote up some new vocabulary on the white board which she took from the recordings, and reminded the students to learn from

any new vocabulary they encountered while doing the exercises. (Lec11's class, 14/5/2015)

While it is important to describe the strategies the lecturers use to extend PSTs' speaking turns, it is also important to identify whether or not the lecturers encourage their PSTs to use certain OCS in and out of lecturers.

4.4 Do the lecturers encourage the PSTs to use English oral communication strategies in and out of classes?

Findings revealed that the lecturers were aware of OCS. In this present study, this awareness refers to a state of recognising the function of OCS and employing some of the strategies in English oral communication. Although the findings lacked responses about OCS instruction on the whole when lecturers were not prompted, some lecturers recognised the use of certain OCS, such as using gestures, L1 and asking for clarification, as resources for PSTs to aid their English oral communication when in classroom settings, in some instances. For example, Lec7 stated that her PSTs used gestures when they fail to speak in English because of their English limited vocabulary:

Ya keep talking. Kadang mereka tidak bisa ucapkan kata yang mereka tidak ingat mereka apa? gesture. Artinya mereka pakai bahasa tubuh. Bahasa tubuh. (Lec7: 49)

Ya, keep talking. Sometimes when they cannot say the words that they do not remember they use gesture. It means they use gesture. Gesture. (Researcher's translation, Lec7: 49)

Lec3 said she did not discourage the PSTs from using their L1 when having difficulties speaking in L2. The PSTs could use Indonesian to compensate for expressions that they could not say in English. In Lec3's interview, Lec3 said that because the PSTs "are not born with the language [English]", lecturers shall "let them speak". Lec3 perceived that allowing her PSTs to continue speaking English despite the use of Indonesian could be helpful for the PSTs' L2 learning experience. Yet, for this lecturer, teaching OCS was obviously not a main objective because she did not elaborate on specific details about the why and when her PSTs should use OCS. The way she perceived her teaching practices explained this absence of explicit OCS instruction.

In the following two quotes, Lec3 described how she viewed her teaching and what she expected her PSTs to be able to do after attending her class. In the first quote, Lec3 stated that satisfaction is the key to her teaching practices. She thought that whatever kind of activities she delivered in the classroom, she had to make sure that the activities would please her PSTs. In other words, she might not teach or do something that could make her PSTs feel uncomfortable because they did not enjoy what they were doing in the classroom. For example, as seen in the second quote, what she taught in her Speaking 1 class was what she called “language for survival”, which refers to any useful expressions that L2 learners might want to use for communication in the classroom. This includes introducing oneself and asking for directions. She would not ask her PSTs (who were beginner learners) to perform a classroom activity, in which the level of its difficulties was beyond the PSTs’ level of proficiency, such as doing a presentation on a particular topic:

Because to me teaching is satisfaction. The result is should be satisfaction. Not only my satis, not only the students’ satisfaction but my satisfaction as well. So that’s why everytime if I’m going to the class I have to think very carefully what I’m gonna do to my students so that they will enjoy the class. They are not just learning but they also enjoy the class. (Lec3: 41)

A very very basic one for Speaking 1. Because this is Speaking 1. If Speaking 3, then you can ask them to present something or show and tell something. But this is Speaking 1. That’s why the basic things like what I said before, language for survival. That’s the first thing I’m gonna teach them. (Lec3: 45)

Some of the lecturers’ viewed the use of OCS as solely for dealing with self-oriented communication problems, such as limited English vocabulary and reticence to speak in English. To address these problems, the lecturers used certain ways, such as asking students to memorise a set of vocabulary through more reading activities and various classroom games. As Lec3 put it:

In mastering vocabulary, first like what I did before they have to learn from the song, while they’re learning the pronunciation they also read, acquired lots of vocabulary in that song. That is one of the thing. From game that we’re doing in the classroom, from the feedback in the classroom like while they’re having this conversation, I try to one of one or two things that they cannot find in English and then. (Lec3:54)

The findings also showed that the lecturers designed speaking and listening units to develop the PSTs’ English speaking and listening skills as two distinct skills. The listening unit, in particular, was taught so that the PSTs would become familiar with

taking a listening test, such as TOEFL, a compulsory test for the completion of the undergraduate degree. Lec9 and 10, respectively, said:

Lalu kalau dia Listening 3 itu, kemarin Listening 3 itu, itu mahasiswa diminta dia biar bisa menganalisis ya. Dia diminta bisa menginterpretasi, ... setelah itu mereka lebih banyak belajar TOEFL. TOEFL Listening. (Lec9:41)

Then in Listening 3, like what I taught yesterday, I asked students to be able to do an analysis. I asked them to be able to interpret, ... after that they fully focus on learning TOEFL. TOEFL Listening. (Researcher's translation, Lec9:41)

Makanya dibagi sebelum matakuliah itu kita tetap mengambil analytical listening, critical listening, setelah itu baru kita permantap di TOEFL ... Jadi itu kita bagi dua begitu. (Lec10:4)

So, we also teach them analytical listening, critical listening, then we drill them in TOEFL ... So we divide the focus of teaching listening into two. (Researcher's translation, Lec10:4)

To sum up, a major finding of this study was that, on the whole, lecturers on the English Education Program are not completely familiar with what OCS are and, in fact, how to encourage their PSTs to use them. Among those who were able to elaborate on OCS in any detail were Lec6 and 7. Lec6, for example, said that she considered the teaching of OCS to be important:

Well such a hard thing to answer because I guess it's because it works for me I will say yes. Because it works for me I will say yes. (Lec6: 48)

Lec6 claimed that she had used some OCS and they helped her in some ways although she was not confident in her understanding of OCS. As an L2 speaker of English, Lec3 used certain strategies, such as asking for clarification, encouraging the use of L1, and paraphrasing, when in the classroom, without fully realising them. She also used them in L2 communicative situations while she was still completing her bachelor or master's degree. Likewise, Lec7 considered OCS instruction as useful for the PSTs, but viewed it rather differently:

Iya artinya jangan terlalu kita mengikuti kemauan kita sendiri. Akhirnya mereka tidak bebas untuk berbicara kalau selalu mengikuti sesuai rule kita. Iya kan? Kalau kita berikan kebebasan mereka untuk berbicara, jadi artinya kita tidak mengatakan oh pengucapannya harus begini harus sesuai dengan begini. Iya kan? (Lec7: 57)

Yes, I mean we should not always follow our own rules. Otherwise, our students will not feel free to speak because they are pushed to follow our

rules, right? So, we need to let them speak freely, which means we do not tell them that they should always pronounce word this way or that way, right? (Researcher's translation, Lec7: 57)

Lec7 implied that her PSTs, at their level of English proficiency, should not be taught a lot of explicit information they may not be able to understand. Otherwise, this lecturer argued, the PSTs would not be willing to communicate orally in English. She gave an example of teaching pronunciation and suggested that lecturers “need to let them [the PSTs] speak freely”, without constantly telling them that they should pronounce English words in certain ways. This might indicate that she felt that at a certain level of English oral proficiency, opportunities for the PSTs to practise English orally should be prioritised over the learning of English oral communication strategies. In other words, this lecturer seemed to emphasise the importance of implicit learning and fluency over explicit learning and accuracy.

4.5 Summary

This chapter has addressed the key research question and guiding questions in detail. Informed by thematic analysis, the findings revealed what objectives of teaching English oral communication that the lecturers had, the type of English oral communication challenges that the lecturers perceived the PSTs to be experiencing, how the challenges were addressed, and whether or not the lecturers encouraged the PSTs to use OCS in and out of classes. Overall, encouragement of PSTs' use of OCS received little attention in the English Education Program. In other words, the encouragement of OCS was not part of the lecturers' repertoire of teaching practices, as indicated by how the lecturers viewed the English oral communication challenges, handled the challenges, and set up objectives in teaching English oral communication. Despite the fact that the lecturers had some awareness of the use of OCS with learners of a second language, their experience in facilitating the use of OCS with their PSTs was very limited.

This chapter provides a detailed discussion of the key research findings presented in Chapter 4, with reference to each of the guiding research questions and in relation to previous research studies. The first section discusses the lecturers' objectives of teaching English oral communication, whereas the second section presents the PSTs' English oral communication challenges in the English Education Program in Indonesia. The third section outlines a number of chosen techniques and strategies that the lecturers use to cope with the challenges. The fourth section talks about whether or not the lecturers encourage the PSTs to use OCS in and out of classes.

The discussion presented in this chapter is grounded in the conceptual framework of the research. This framework entails several underpinning conceptual areas, aimed at informing the discussion of the research findings. These areas cover teaching approaches, sociocultural theory, critical language pedagogy, World Englishes, psycholinguistics and language teacher cognition. The framework also accounts for two other areas, namely the context and the lecturer. The 'context' includes language learning, ELT in Indonesia and English uses in the world, whereas the 'lecturer' entails the lecturers' profiles, their knowledge and their pedagogical practices. This chapter, therefore, discusses the findings by relating them to previous studies, informed by the conceptual framework.

Central to the discussion of the research is the lecturers' perspectives on oral communication strategies instruction (OCS). OCS in much previous ELT literature are described as tools that language learners can use to deal with oral communication challenges and to enhance the quality of involvement in such communication (Ghout-Khenoune, 2012; Jamshidnejad, 2011; Tarone, 1981). The literature suggested that studies about how English language lecturers perceive the teaching of OCS in English Education Programs, both in EFL and ESL settings, was rare. Only those which focused on examining OCS uses and classifications were more readily found. That is why, this present study aimed to bridge the gap in the existing body of literature on OCS instruction by investigating the voices of lecturers working on an English Education Program in an Indonesian university.

As studies about OCS in English Education Programs are limited, it is difficult to make a direct comparison between the findings of the present study and other previous studies. Nevertheless, the present study attempted to compare the findings from the four guiding research questions and the findings of other studies, helping to extend knowledge about how lecturers see OCS instruction in English Education Programs in Indonesia. In this present study, all participating lecturers were asked questions in order to figure out their perspectives on OCS instruction. They were asked how they understand challenges in English oral communication that their PSTs might experience. Their responses to this question would help the researcher relate the findings generated from the responses to some earlier studies of OCS, such as in Tarone (1981), Dörnyei and Scott (1997), Ghout-Khenoune (2012), and Rohani (2011).

In the following sections, the findings of this present study are discussed, with reference to the relevant literature. To begin with, lecturers' objectives in teaching oral communication are presented.

5.1 Objectives in teaching English oral communication

The first subsidiary research question addressed the lecturers' objectives in teaching English oral communication. The main purpose of identifying the objectives was to detect whether or not improving OCS was part of the lecturers' teaching practices. This identification suggests that there was very little that could be elicited from the lecturers about OCS instruction. This could mean that the lecturers considered teaching other strategies, other than OCS, were more important as ways to assist their PSTs in dealing with various English oral communication challenges. In fact, it appeared that the term 'OCS' was relatively new for the majority of the lecturers because very few of them referred to the use of any of the strategies when asked about how they helped to improve their PSTs' English oral communication skills. Even if they did, the strategy that the lecturers said they used was similar and nothing further could be inferred about how the use of the strategies, which varied greatly, could be taught to the PSTs.

The lecturers' objectives in teaching English oral communication were classified into six themes, namely, teaching for their own learning, improving PSTs' English language speaking skills, improving PSTs' English language listening skills, developing PSTs' confidence in speaking English, and helping PSTs to pass the oral component of the TOEL. In the following paragraphs, each of these themes is discussed.

As the findings showed, the lecturers had various focuses when setting up their objectives in teaching English oral communication skills. Some of them did not only aim to help the PSTs to be better in English oral communication skills, but also sought an opportunity to improve their own language skills proficiency which they felt to be inadequate. Lec1, 9 and 11, for instance, stated that one of their objectives in teaching oral communication in the DEE program was to improve their own communication skills in English, especially speaking and listening.

The term 'improvement' for these lecturers meant different things. While Lec1 saw it as an effort to maintain and continuously develop her English language speaking skills by practicing communication in English in the classroom situation, Lec9 and Lec11 considered it as an opportunity that enabled them to notice their current listening skills progress and to make improvements. Lec9 and 11 explicitly stated that they were not satisfied with the current state of their language skills. Lec9 contended that she became unconfident about her listening skills after taking the IELTS and decided to teach listening for own self-learning, as did Lec11, who said he scored low in the Listening Comprehension Section of IELTS.

This is a typical pedagogical issue in language classrooms in EFL countries, such as Indonesia. Many English language teachers at the school level continue teaching the language without sufficient English teacher training. Others might have received proper training, but were unable to improve their language skills for various reasons. Dardjowidjojo (2003), as cited in Marcellino (2008), found that numerous graduates of the English Education Program in Indonesia were not yet competent users of the language they learnt.

However, it was surprising to find that the issue of English language teachers' competence also existed among the English language lecturers at university level, particularly in the context of the teacher training program. Zein (2014, p. 10) asserted that "... there is a gap of quality between educators in various English departments across universities in Indonesia.". This gap refers to different issues, such as the failure to become a model for and to give inspiration to teacher education candidates (Zein, 2014). Indeed, in the context of the English Education Program, the expectation of having a language model and being an inspiration in the secondary schools should be high because the program aims at providing these schools with competent English language teachers (and users).

For some of the lecturers in this study, this would remain a challenge as they also teach for the sake of improving their own language skills. What is more challenging is that the lecturers were not only required to teach per se, but also to conduct research and community services, as part of their *Tri Dharma Perguruan Tinggi* or the Three Principles of Higher Education stipulated in the Government Law of Republic of Indonesia No. 20/2003 on Standard of National Education and No. 14/2005 on Teachers and Lecturers. In fact, many of them were performing other administrative duties or involved in various events held at the university, such as being a secretary or treasurer of an organisation within the university where they were working and becoming part of a committee for the graduation ceremony. With all these duties to perform, it is undoubtedly that many of the lecturers would struggle with time to ensure all these duties were accomplished. Hayes (2009, p. 8) argues that these sort of activities would indeed impact on "the quality of the classroom experience" of both the lecturers and the PSTs.

Another identified theme related to the lecturers' teaching objectives was improving PSTs' English language speaking skills. Some of the lecturers reported that they wanted their PSTs to become fluent speakers of English, and another three lecturers stated that they expected their PSTs to be able to speak in public, to have native-like pronunciation and to have good pronunciation. Promoting good pronunciation as an important skill to master in language learning is also addressed in a number of previous studies. For example, Derwing and Munro (2005, p. 388) believed that explicit instruction of pronunciation would enable English learners to observe "the

differences between their own productions and those of proficient speakers in the L2 community”. Hinkel (2006), on the other hand, suggested that EFL teachers need to change the way they teach pronunciation by emphasising more on comprehension rather than native-like accent, because today’s use of English also involves those people who are categorised in the traditional term ‘non-native speakers of English’.

These findings impact on the teaching of English in the EFL context, particularly in the English Education Program. Because English language users now are from various linguistic backgrounds, the teaching of English language skills, such as oral communication, needs improvement as well. For this purpose, lecturers in the English Education Program may need to continuously attend to training that encourages improvements in pronunciation pedagogy and is informed by research findings (Derwing & Munro, 2005). This is to ensure that the lecturers are well prepared to respond to teaching materials that are intended to be used in multiple pedagogical settings (Derwing & Munro, 2005). Khamkhien (2010) asserts that EFL teachers may also want to adjust the way they monitor their students’ progress, such as through a series of assessments that highlight the measurement of students’ proficiency development.

The findings of this study indicate that many of the lecturers stress production when teaching oral communication. The data indicated that the lecturers perceived that by taking the speaking class, their PSTs would be able to demonstrate some language skills associated with speakers of English as a first language via production. When asking about the purposes of teaching speaking or listening, they rarely mentioned any expectations that their PSTs would be independent and knowledgeable when dealing with communication breakdowns. Yet, this does not necessarily suggest any problems with lecturer teaching practices and may instead indicate limited opportunities for PSTs to learn how to deal with oral communication breakdowns in the classroom.

The absence of explicit OCS instruction shows that perhaps the surroundings do not yet support the use of English consistently. As Lauder (2008, p. 13) states, the use of English in Indonesia is limited to “its utilitarian value in accessing information that can promote economic growth”. Even though there is an increasing use of English in

different walks of life, in most cities in Indonesia, the use of English remains restricted to serve administrative purposes. In fact, in the English Education Programs, the use of English for daily communication has yet gained much support from both the lecturers and the PSTs. Even though they are speakers of English, they do not always use this language to communicate with one another, which helps them find ways to improve their English oral proficiency level. Whilst Lec11 reported that “every people in English area using Indonesian language”, PST1 asked “how come our friends and then the lecturer itself do not use English in the class?”.

Another theme that this present study identified was improving PSTs’ English language listening skills. The findings showed that the reason for such improvement, as reported by Lec8, Lec9, and Lec11, was that many of the PSTs had difficulties in understanding what was being said when they were listening to recordings. Research has shown that listening for EFL learners, particularly novice learners, can be problematic due to a number of factors, such as increased speech rate and the complexity of speech sound (Renandya & Farrel, 2011), and strategies to improve listening has been given extensive attention from many scholars (e.g. Waring, 2008; Zhang, 2007). Waring (2008) focuses on encouraging students to undertake extensive listening, where students have the opportunity to select listening materials that suits their interest, whereas Zhang (2007) highlights the importance of addressing listening challenges to establish an appropriate follow up classroom listening activities. Mostly following Zhang (2008), it is suggested that recognising personal listening challenges and doing extensive listening can be useful for the PSTs, particularly because they enable the PSTs to identify their level of listening comprehension skills and possible strategies to improve their L2 listening skills.

It is understandable why some of the lecturers, such as Lec8 and Lec9, argued that comprehension skill is an important aspect of learning in the listening classes. Lec9 reported that if lecturers managed to improve this skill, the PSTs would be able to deal with listening activities. Yet, with this in mind, OCS instruction seems to be beyond the lecturers’ teaching practices because it is not obvious in the lecturers’ responses, in the classroom observations or in the syllabuses. Strategies that the PSTs can use to deal with communication breakdowns, such as difficulties in understanding what has just being said, may not be relevant to the lecturers and the

PSTs because of the nature of the listening classes in which the core activity is to practice listening to recordings. Such a practice may not support the improvement of the PSTs' skills in negotiating meaning as it is an example of one-way communication. In fact, it is meant to help the PSTs develop their skills in understanding recorded oral communication for certain specific purposes, such as to sit a test.

Nevertheless, this does not mean that the lecturers should accept the idea of integrating OCS instruction per se in their teaching practices, considering the variety of teaching and learning goals that both the lecturers and the PSTs have. In their listening classes, at least, lecturers may assist PSTs to pick up some listening strategies that they can use, for example, to complete any communicative activities in the speaking class. The listening and speaking classes can promote an integrative concept which aims at promoting the development of the PSTs' English oral proficiency through interrelated classroom activities. For this purpose, the active participation of PSTs becomes crucial because it can provide them with the opportunities to engage in English use situated in the classroom. Zacharias (2014) sees such participation as an important aspect within English language teacher preparation programs, and suggests that a careful design of teaching techniques to stimulate students' active participation is imperative.

In addition to improving PSTs' English language listening skills, this study found 'developing PSTs confidence in speaking English' as the other theme related to the lecturers' objectives in teaching oral communication classes. This theme was generated from the interview transcript analysis with Lec4. Lec4 asserted that many other lecturers had the same motivation in teaching Speaking 1, namely, to improve their PSTs' self-confidence. This lecturer reported that improved confidence helped the PSTs "deliver the message" and "transform their ideas" when speaking in English (Lec4: 2). One lecturer, Lec2, lent support to Lec4's argument by saying that many of the PSTs remained as passive users of English in the classroom. This lecturer, Lec2, asserted that:

Ya to be honest that not all students can be talkative in the class and perhaps, I think, that's because they have a less self-confidence. (Researcher's translation in italic, Lec2:30)

Lec2's opinion implies that improved self-confidence allows the PSTs to maximise the use of English orally in the classroom situation. For Lec8, this effort in improving PSTs' confidence is related to "motivation" to teach English, whereas Lec6 related it to the "yes-yes culture" that the PSTs embraced, which means "teacher is everything". This "yes-yes culture" shows that many of the PSTs in the DEE might not have been encouraged to be responsible for their own learning. Lap (2005) as cited in Vo (2016, p. 120) refers to this culture as a result of teachers "giving learners the fish", which means the teachers' role in the classroom is limited to transferring knowledge. Encouraged or motivated language learners would usually find ways to improve their language competence, such as practicing communication in L2 as often as they can.

The lack of self-confidence associated with the PSTs in an English Education program in Indonesia reflects a similar situation in other countries where English is not the primary means of communication, such as Japan (Fennelly & Luxton, 2011), Palestine (Alyan, 2013), and Turkey (Bekleyen, 2009). All these studies revealed that one of the major factors that contributed to the lack of self-confidence that English learners demonstrate is related to how they receive English instruction in their previous foreign language education, which is not adequate to prepare them to operate independently using the language they learn. This can be attributed to the fact that much classroom-based teaching, especially in the EFL situation, aims at preparing school students for tests (Richards, 2015, p. 6). As a result, improving the students' English oral proficiency level, which improves self-confidence in L2 use, receives little attention.

The last objective that came out of the findings is 'to help PSTs to pass the oral component of the TOEFL'. This is certainly related to skills that the PSTs need to take a test and obtain an acceptable score. TOEFL is an obligatory test that the PSTs must take before they begin writing their undergraduate theses. For them, failure to obtain an acceptable score means failure to write the thesis in time because they need to take another test until the scores are acceptable. Given this test is in a 'prestigious' position in the DEE curriculum, it makes sense that intensive training in listening also focuses on improving PSTs' listening comprehension in TOEFL like tests. Improved skills by PSTs in TOEFL may not only benefit themselves as individuals,

but also be useful for their English language teaching careers in which, as Lengkanawati (2005, p. 89) posits, “a better trained teaching force is an important factor in maintaining educational quality”.

Overall, the findings of the present study showed that the lecturers’ objectives in teaching English oral communication skills can be arranged into two groups. The first group includes only one objective, i.e. teaching to improve own learning, and is called a lecturer-oriented goal. The second group, a PST-oriented goal, subsumes improving the PSTs’ English language speaking skills, improving the PSTs’ English language listening skills, developing the PSTs’ confidence, and helping the PSTs to pass TOEFL. Unlike a teacher-oriented goal that focuses on making improvements on the lecturers’ pedagogical and language skills, a PST-oriented goal focuses on developing the PSTs’ skills in many aspects of language learning. Some lecturers who were teaching listening units mainly embraced the former goal, other lecturers embraced the second.

The main reason why some of the lecturers chose to have the teacher-oriented goal is somewhat difficult to explain because this study lacked sufficient data to use as evidence for such an explanation. However, identifying the relationship between the lecturers’ profile and what they said during the interview session may generate data which is useful for discovering the main reason. These lecturers, who reported that they also wanted to improve their English oral communication skills in listening and speaking, mainly picked up English language from classroom instruction in their home country (Suryanto, 2015). This means that the majority of input they received, which can be influential to the progress of their oral proficiency improvement, is from having interaction with their Indonesian peers and teachers, who are also speakers of English as an additional language (Mattarima & Hamdan, 2011). More or less, the learning output of these lecturers, particularly in the domain of oral communication, is influenced and characterised by learning environments in Indonesia.

It is difficult in this study to claim that having rich interaction with Indonesian English speakers in Indonesia would often yield less effective result than that with people who speaks English as their primary means of communication. If a claim is to

be made, this study needs to focus investigation on various aspects that are related to the claim. Although Indonesian English speakers can be effective teachers, there still appeared to be an unsuitable level of oral competency among the lecturers who were teaching oral communication skills. The raising of this level needs to be addressed tactfully to support improvements in the institution where the study was carried out. Wati (2011) and Zein (2014) have highlighted such need for constant improvement in teacher candidates' English language skills.

All in all, it can be assumed that improved skills in communicating orally in English is intensively addressed in the speaking classes of the PSTs, while the listening classes are designed exclusively for the purpose of learning to do the TOEFL. Yet, addressing the skills in the speaking class by the lecturers raises some questions: Does it involve encouraging the PSTs to use the strategies related to managing communication breakdowns? Or does it focus mainly on training PSTs to be skilful in a one-way communication? The following section address these two questions.

5.2 English oral communication challenges in the context of the English Education Program in Indonesia

The second guiding research question addressed the lecturers' perspectives about oral communication challenges that the PSTs might experience in the classroom context in Indonesia. To uncover their perspectives, the lecturers were interviewed and observed before being asked to provide the syllabuses that they were using in teaching oral communication classes (speaking and listening). The analysis identified four major themes that described the perceived oral communication challenges. These challenges fell into four groups, namely, linguistic proficiency challenges, psycholinguistic challenges, English language engagement opportunity challenges, and background knowledge challenges. These challenges were similar to those listed by Tarone (1981), i.e. gaps in linguistic or sociolinguistic resources, and Dörnyei and Scott (1997), namely, own-performance problems, as seen in the table below.

This Present Study	Tarone (1981)	Dörnyei and Scott (1997)	Description
Linguistic proficiency challenges	Linguistic	Own-performance problems	<i>Similar</i>

Psychological challenges	n/a	Other-performance problems	<i>Similar</i>
English language engagement opportunity challenges	n/a	n/a	<i>New category</i>
Background knowledge challenges	n/a	n/a	<i>New category</i>

Table 10 Oral communication challenges classification

From their responses, the lecturers perceived a lack of exposure to English use and background knowledge about the topics of classroom discussions as challenges in English oral communication for the PSTs. This means that, for the lecturers, English oral communication challenges also involved things beyond the boundaries of oral communication itself. In other words, what becomes difficult for the PSTs when communicating orally in English, according to lecturers, is not simply delivering or receiving messages. The difficulties also encompass limited opportunities to use English and lack of knowledge about a particular topic of classroom discussions.

The findings showed that the four types of oral communication challenges that the PSTs experienced are in the domains of English grammar, English intonation, English pronunciation and English vocabulary. These are the typical challenges that English language learners elsewhere might experience. Mukminatien (1999), as cited in Widiati and Cahyono (2006), found that such challenges were also experienced by the students who major in an English Education Program. Some of these typical challenges appeared in the area of grammatical accuracy, word stress and intonation, and incorrect word choice (Mukminatien, 1999, as cited in Widiati & Cahyono, 2006). Such findings are not peculiar to Indonesian learners alone. Alyan (2013) also found this in the context of Palestinian English language learners at the tertiary level. Alyan found that many of the participating lecturers reported that poor pronunciation and intonation were sources of difficulties that impacted on their students' speaking ability.

Why the PSTs in the English Education Program in Indonesia continued to experience such challenges can be related to how they received English instruction

during their high school studies and how they used the language to practise communication. In Indonesia, English occupies the domains of education and employment, but there remains a wide gap in terms of how language instruction operates in the classroom and how the employment sectors respond to the needs for the language (Lie, 2007; Suryanto, 2015). In the domain of education, in many rural areas in Indonesia, the practice of ELT at the secondary level is a complex picture, ranging from teachers' limited professional and pedagogical competence to learners' lack of access to English users (Suryanto, 2015). In fact, it is often portrayed as a teacher spending the entire teaching hours explaining lesson materials, or at worst, dictating from textbooks (Lamb & Coleman, 2008), leaving no time for students to communicate using the language.

Such a teacher-centered teaching approach is influenced by a range of factors, some of which include the size of the class, the curriculum, and as mentioned above, the teachers' pedagogical competence. Kurihara and Samimy's (2007) study described how these factors became influential in English classrooms in Japan. These researchers reported that with 36 to 42 students in the classroom, the Japanese English language teachers felt it difficult to apply pedagogical skills they obtained during teacher training programs. Likewise, at the secondary school level in Indonesia, Indonesian English teachers have difficulties in delivering the English syllabus effectively to approximately 40 to 50 students in the classroom (Lie, 2007). This large class size remains an issue in the English Education Program at the tertiary level.

Why it is hardly feasible is due to a number of reasons. First, many Indonesian learners of English demonstrate different levels of English proficiency (Lie, 2007; Suryanto, 2015), with the majority being beginners. Second, students demonstrating ability in speaking English feel they may be seen as showing-off in front of their peers. Third, because they share the same lingua franca (Indonesian), all the students prefer using Indonesian to English when interacting with one another and with their teacher (Suryanto, 2015). In addition, the allocated time for English tuition at secondary schools may not be sufficient to accommodate the different needs of the students in the classroom (Mustafa, 2001; Sahiruddin, 2013). All these reasons can lead to the absence of collaborative classroom activities. With this absence,

promoting meaningful L2 interaction in the classroom can be difficult to facilitate because of the lack of competent language models in the classroom-based L2 interaction, coming from the teachers.

With regard to teachers' pedagogical competence, many language classrooms in rural areas across Indonesia lack effective English language teachers. To point out this shortage is important because teachers are role models that the students can imitate when learning a new language (Klanrit & Sroinam, 2012). When teachers lack ability, for example, in spoken English, it is difficult to expect them to encourage their students to speak English. This is often the case with English language teachers in rural areas in Indonesia whose expertise is not in English Education (Suryanto, 2015). They are often assigned to teach English because the schools where they work do not have trained English language teachers. Also, there is often an exclusive classroom focus on English textbooks, with the main activities being based around completing written tasks. This aspect of the learning context (Canagarajah & Ashraf, 2013), seriously constrains teachers in helping to develop students' English oral proficiency.

In terms of the psychological challenges, the lecturers reported that one of the challenges that their PSTs faced was a lack of confidence in speaking English. A lack of confidence can also be attributed to a socio-cultural aspect. The lecturers perceived that the PSTs were under confident because of at least two reasons. First, PSTs felt nervous when speaking because they were afraid of making grammatical mistakes; second, they lacked ideas about what to share when being asked to talk about a particular given topic. This concurs with Alyan's (2013) findings in Palestine, which revealed shyness and fear of taking risks when speaking in English caused Palestinian English learners to feel inhibited to speak English. Jones (2004) adds that one contributing factors to shyness and fear of taking risks in language classroom is the 'culture of the classroom'. Jones (2004) believes that language learners are more likely to be able to cope with shyness, for instance, in a stress-free learning environment.

To avoid making mistakes in speaking is a typical excuse for many language learners who are reluctant to practise using the language they are learning. One plausible

reason for this reluctance is because they lack experience in using English orally (Suryanto, 2015; Suryati, 2015). These students may not be familiar with expressing ideas in English in front of their peers during high school. Giving a presentation in English may be a totally new experience for them. As mentioned earlier, there are various factors that contribute to students feeling uncomfortable, one of which stems from the teachers, which can lead to language anxiety. Jones (2004) describes language anxiety as a feeling that causes language learners to refrain from engaging in the classroom interaction in order to avoid negative evaluation from their peers (one manifestation of language anxiety) due to their level of proficiency.

English language classrooms in Indonesia, like in many other non-English speaking countries, play a key role in providing students with an opportunity to engage themselves in English-based classroom activities, which help promote oral communication skills. However, in reality, many English language classrooms in Indonesia fail to play the role effectively (Maulana, Opdenakker, Stroet, & Bosker, 2012; Suryati, 2015). One of the reasons for this is that there is not enough stimulation in the classroom motivating students to use English for communication purposes (Yulia, 2013), and this lack of stimulation remains a challenge for PSTs majoring in the English Education program. Yulia (2013) maintains that a lot of the teachers she investigated claimed that they preferred to speak in Bahasa Indonesia to help their students understand the lessons, even though they believed that it is useful for their students' English improvement if they speak in English.

Another reason for such a problematic situation in the English language classrooms in Indonesia is related to the curriculum (Lie, 2007). In the Indonesian educational curriculum, a success in the national examination is a major requirement for graduation into a higher level of education. English is one of the subjects that is tested in this examination, making it a high stakes test (Sulistiyio, 2009). This means, failure to do the English test may negatively affect the students' assessment for graduation. Given this 'exclusive status', many English language teachers across secondary schools in Indonesia use a textbook-oriented teaching approach, aiming solely to drill students' skills to take the national examination (Lamb & Coleman, 2008). As a result, the majority of high school graduates learn English for the sake of passing the national examination.

As potential English language teachers, PSTs majoring in the English Education Program are expected to take any opportunity that enables them to develop their English proficiency level, especially in speaking, which many of them find to be challenging. However, as lecturers in this present study described, lacking ability in English oral skills causes many of the PSTs to refrain from engaging in classroom activities where they are expected to actively use English. The PSTs need to develop not only their pedagogic skills, but also their language skills (Zein, 2014), especially in the domain of oral English. This balance in improved language and pedagogic skills is explicitly reinforced in Chapter 3 Section 9 of The Decree of Government of Republic of Indonesia No. 19/2005 on the National Standards of Education, one of which regulates the standards for graduates' competence in three areas: attitude, knowledge and skills (Departemen Pendidikan Nasional, 2006).

The third challenge that the lecturers talked about was a lack of English language engagement opportunities both in and outside the classroom. One of the lecturers claimed that this was due to the limited teaching hours, whereas another lecturer related it to the PSTs' low levels of confidence in using English orally. Yet, surprisingly, one of the PSTs revealed a different reason. This PST claimed that many of the lecturers, in fact, do not use English as a dominant language of instruction in the classroom, and this negatively impacts on the oral English proficiency of the PSTs. This is also echoed in Zein's (2014) study, in which Zein found that many of the lecturers in English Departments in Indonesia were not satisfactorily competent and failed to provide students with adequate language models. This finding is also reflected in Fareh's study (2010). Fareh contended that many English language teachers in Arab schools were also not qualified to teach English because many of them had no English teaching preparation. Consequently, the English classrooms at these schools were run mostly in Arabic, minimising the students' opportunity to engage in English activities (Fareh, 2010).

Nevertheless, the findings mentioned above do not suggest that lack of English engagement can be attributed to the competency of the lecturers, nor that exclusive use of English is better than using Indonesian. Instead, what is important to bear in mind is that language learners, particularly those who will teach the language as teachers in their future careers, need sufficient exposure to English users by

interacting using the language they are learning in and out of classroom context (Panggabean, 2015). This is because, as García Mayo and Ibarolla (2015) point out, effective L2 interaction helps a language learner obtain input, produce output and receive feedback in various forms with regard to the output, which facilitates effective language learning. Effective here means an improved level of proficiency, indicated by various factors, such as the ability to engage in L2 oral interaction with the use of extensive vocabulary. Despite the fact that reaching a good level of proficiency takes time, this endeavour remains achievable for language learners.

The fourth challenge that the lecturers mentioned was background knowledge. Two of the lecturers related this challenge to their PSTs' inability to talk about topics in depth. Another lecturer related the challenge to the PSTs' inability to understand messages due to their low level of linguistic proficiency. The first two lecturers perceived that because many of the PSTs did not have enough exposure to general knowledge available on television and other printed media, the PSTs found it difficult to participate, share ideas, and be critical in speaking activities. In Fareh's (2010) study, this lack of exposure to general knowledge was seen as a result of having a lack of motivation to learn English. Some of the lecturers' comments on their PSTs' attitudes, according to Fareh (2010), were about the students' inability to think and unwillingness to learn.

The next section discusses some techniques and strategies that lecturers of the present study use to deal with English oral communication challenges.

5.3 Techniques and strategies employed by the lecturers to deal with English oral communication challenges

The third guiding research question addressed the lecturers' perspectives on how they coped with English oral communication challenges that their PSTs' experienced. The analysis showed that there were a number of techniques used and strategies developed by the lecturers to handle the challenges, namely, "Setting up classroom activities", "Setting up group work", "Tolerating and encouraging the use of L1", "Encouraging independent learning", "Using strategies for extending speaking turns".

The lecturers reported that in order to encourage PSTs with basic English proficiency to use English when communicating in the classroom, they needed to make use of various classroom activities, such as games and Show and Tell activities. By using games, the lecturers hoped that the PSTs would speak in English in the classroom's activities. Avinash (2016) asserts that using language games not only facilitates language learning, but also encourages language learners to learn. Findings of this present study are supported by Liu and Chu (2010) who found that the use of a ubiquitous game, such as HELLO (the Handheld English Language Learning Organization), provided opportunities for Taiwanese students learning English to engage in enjoyable classroom activities that assisted them in listening and speaking. Yet, the procedures used and how they work in these two classroom contexts remain different. For instance, HELLO is a sophisticated game that employs various learning tactics to encourage students to speak up (Liu & Chu, 2010). Talking Stick is a straightforward procedure where PSTs are simply asked to talk about a chosen topic in turn.

Another difference between the games used in the two different contexts above is their levels of interactivity. Unlike HELLO which enables the students to practise communicating in an actual context (Liu & Chu, 2010), the Talking Stick or the Show and Tell places great demand on individual oral presentation skills, with little emphasis on interactive speaking activities that reflect day-to-day communication. Moreover, in the Talking Stick activity, PSTs with a good level of speaking skills may think that speaking before their peers is a stress-free activity, but PSTs with basic English proficiency may not. For these PSTs, playing the Talking Stick activity can increase their speaking anxiety because of their lack of linguistic competence. In contrast, the HELLO game allows the participating students to engage in various activities which involve genuine communication and to gain confidence in communicating in English with a virtual learning tutor and also receive feedback (Liu & Chu, 2010). All these, however, do not suggest that the PSTs and the lecturers are not able to cope with 'sophistication' in utilising classroom technology.

Nevertheless, despite a lack of day-to-day conversation characteristics, the Talking Stick and the Show and Tell activity may be useful for the lecturers to utilise. When the PSTs are asked to practise using English orally by talking about a particular

chosen topic or one of their favourite belongings before their peers in the classroom, the lecturers should be able to notice OCS in practice. As Klimova (2015) put it, games enable teachers to identify their students' weaknesses when speaking in the language they are learning in the classroom context. Yet, there is a potential drawback regarding a continuous use of these non-modern games, as PSTs can easily get bored playing the games because they are less challenging and may increase their anxiety levels. What remains important is to encourage the PSTs to participate in activities that expose them to meaningful uses of English and to continuously maintain the encouragement.

Applying computerised-based games, such as digital task-collaborative board games, is helpful to language learners “ ... in encouraging them [in] speaking by playing and learning with sufficient context-relevant immersions and efficient game instruction management” (Wu et al, 2014, p. 224). Vardanjani (2014) contends that digital-based games assist English language teachers to create an enjoyable and entertaining classroom atmosphere to facilitate students' learning achievement. Given that the PSTs will eventually be English language teachers, it is important that they expand their knowledge about various classroom activities, such as how to use digital games to foster English language learners' oral communication skills, in order to facilitate their future school students' learning achievement. This consideration focuses on the fact that the PSTs shall not only be treated as a participant in the game, but also be educated as the facilitator of the game for their future English language classes.

Another strategy that the lecturers used to deal with the communication challenges in the classroom is setting up group work, aiming to encourage PSTs to gain confidence and speak up with peers in English. Anwar (2016, p. 228) supports the benefit of this and claims that working in groups enables learners to be familiar with “the habit of sharing, arguing and presenting ideas in pairs or to other limited members”. Some lecturers in this present study had different views from Anwar (2016), however. These views are now in line with Kayi-Aydar (2013) who found that group work in the context of language learning was often ineffective because the students became less responsive to their peers due to various reasons, such as the distancing effects of power among the group members. This, of course, does not demote the useful role that group work can play because there might be cultural or contextual issues that

influence how group work operates. What it suggests though is using group work should be considered carefully when engaging students in English-based activities. This means the lecturers need to be aware of how and when group work can bring about effective outcomes for the students (Anwar, 2016).

Kayi-Aydar's finding is similar to the evidence found in the observations of some of the lecturers' classrooms in this present study. During the observations, instead of using English to communicate with their peers, many of the students used their L1 (Bahasa Indonesia). The use of English was mainly heard from students with a good level of oral English proficiency. What is relevant in this situation is the lecturers' tactics in setting up effective group work which can stimulate all the group members to communicate in English, and help them use their L1 necessarily. As Mercieca (2014, p. 39) suggested, "group work and mingling ... allow student to student interaction and promote communicative competence". In fact, what seems to be crucial is that, Mercieca maintained, lecturers need to ensure that through group work "social and cultural interaction" can also be facilitated. When they are facilitated, language learners may have opportunities to make the most of using L2 and to nurture skills that they could use to deal with certain pitfalls emerging from learning collaboratively within groups, such as disagreement among group members (Gillies, 2016; Johnson & Johnson, 2009).

Group work as a strategy to foster students' communication skills can be seen in Huong's (2007) study. Huong found that group work, which was assisted by a student with a higher proficiency level, provided opportunities for the low proficiency students to communicate their ideas within the group and speaking turns were allocated equally. Low proficiency students who were not accompanied by a more proficient student had limited speaking opportunities. In addition, Gillies (2016) sees the importance of scaffolding by lecturers as not only enabling all group members to focus on completing given tasks, but also more importantly encouraging them to develop dialogue which is supportive to their group endeavours. This model of group work, which promotes dialogue for collaborative learning, was not consistently facilitated in the groups observed in the present study.

In addition to group work, the lecturers in the present study reported that in order to cope with English oral communication challenges, they allowed their PSTs to use Bahasa Indonesia, their first language. This finding was echoed in Sali (2014) who investigated an EFL classroom in Turkey and suggested the use of L1, particularly by the teachers, helped the students overcome anxiety in learning English and enabled them to continuously participate in the classroom interaction. In a similar vein, Ghorbani (2011, p. 1658) believed that allowing the use of L1 during pair/group work helped “boost the atmosphere in the group”. As such, L2 output from student-student or student-teacher interaction can be facilitated provided that the rules regarding the uses of L1 are well-defined and accommodated in the output.

However, the use of L1, especially by the lecturers in the present study, served different purposes. One of the PSTs pointed out that the use of L1 in the classroom by some of the lecturers was often for a translation purpose, aiming solely to help PSTs understand what the lecturers had just said in English. PST5 argued that the use of L1 in this context was not helpful for the PSTs’ oral communication skill development:

Sangat besar tapi sayangnya yang saya lihat disini kalau inginnnya saya sih full English itu penting pembelajaran dalam full English, not mixed or in Bahasa karena kita khan kita ini sudah berada dalam program pendidikan bahasa Inggris. Kita bukan lagi jurusan lain yang mesti ditranslate artinya begini untuk ngerti apa tujuannya belajar bahasa Inggris. (Stud5:33)

It’s huge, but unfortunately, what I see here, what I want is full on English. This is important in learning English. Not mixed or in Bahasa because we major in English Education Program. We are not students majoring in another field of study who need a translation in order to understand why they learn English. (Researcher’s translation, PST5: 33)

The statement above indicates that in some cases, the use of L1 during L2 learning in the program may not be well defined and accommodating of L2 output, rather it may impede the development of the PSTs’ skills in understanding L2 outputs. The PSTs are not challenged to make meaning out of the English utterances they hear when interacting, because all the translations of the utterances are made available for them. When they are challenged and motivated, the PSTs may develop their learning strategies and become independent learners, which is influential to the success of their L2 learning, especially in the domain of oral communication. This is in line with Manara’s (2007) study which suggests that the use of Indonesian and English in

the Indonesian EFL classroom should be balanced in order to encourage the less proficient English language learners to find ways to improve their use of English in the classroom.

Another reason why the use of L1 continues to exist in the classroom is related to the lecturers' pedagogic competence. One of the PSTs (PST6: 97) expressed her opinion about this by saying that the lecturers "are not really professional" and "some of them even don't understand what they are teaching". This opinion was supported by another PST (PST1) who expected that the lecturers should have carefully assessed who could or could not pass the units they were doing. Otherwise, PST1 maintained, when the PSTs become teachers, they would do the same thing, i.e. they may not be able to assess their students' language proficiency development properly. Accordingly, PST4 added, there should be improvement with respect to the approaches used in teaching the Listening units, so that each level of the Listening units has specific teaching/learning goals that are different, yet related to one another.

The use of L1 in the EFL classroom, if done properly, can help language learners find ways to improve their oral communication skills. Drawing on James's (1996) work, Du (2016) claims that L1 use by language teachers enables learners to become aware of target language structures and memorise them. At this point, it could be helpful for language teachers to have a clear purpose when dealing with L1 use, i.e. to act as an aid in producing comprehensible L2 output for effective communication (Mercieca, 2014). Jamshidnejad (2011) maintains that the use of L1 knowledge, such as literal translation and switching to L1, in L2 classrooms also helps English language learners to avoid communication breakdown when interacting with peers.

The other strategy that the lecturers used to deal with oral communication challenges of their PSTs was promoting independent learning, something that is seen as influential in improving learners' motivation in learning (Vo, 2016). Through this approach, the lecturers expected that their PSTs would make use of the different learning resources that were made available for them, such as the language laboratory. However, this expectation seems to contradict the reality of how the majority of the PSTs in the present study responded to learning independently. One

of the lecturers argued that many of the PSTs were reluctant to increase their knowledge by accessing online and printed information media. This lecturer said that the PSTs “ ... don’t have like the culture of searching or reading or anything else,” (Lec6: 22), whereas another lecturer contended that “They never learn about the material at home before the class.” (Lec8:59). This situation indicates that many of the PSTs may not be independent learners, and so are those learners in the EFL settings in Vietnam, for instance, where Vietnamese learners of English are dependent upon their teachers as the source of knowledge (Vo, 2016).

In addition to the above contradiction, promoting independent learning among the PSTs can become a difficult task to accomplish with limited learning resources. Both the lecturers and their PSTs had similar voices regarding this difficulty. Lec10 and Lec11, for example, expressed their concerns about the lack of quality listening facilities, such as the audio speakers and the projectors. Lec10 contended that:

Kadang-kadang kami juga malu dengan mahasiswa karena fasilitas di kampus yang seperti ini. (Lec10:32)

Sometimes, we are ashamed because of the current condition of our teaching facilities in this university. (Researcher’s translation, Lec10: 32)

Lec11 added that:

Ya, LCD projector is sometimes ... we don’t have the ... in the classroom and then we have syllabus. Every teacher we have to prepare before we start the class. (Lec11: 40)

These lecturers’ voices are confirmed by the PSTs who reported that the facilities they used in the listening and speaking classes were “not effective” (PST1: 33) and “not maximal” (PST4: 33). In fact, PST6: 102 noted that a language laboratory is not available in the department. This PST said:

We should have that in ... even in my high school, we have it. So, why don’t we have it in university? Especially we learn about a language, specific language. Why don’t we have that? (PST6:102)

Even though most language learning centres do not have language laboratories these days, language laboratories in Indonesia are still very common. As an institution that strives to provide schools with professional English language teachers, the department may need to supply sufficient quality facilities to support the English

language teacher education program (Zein, 2014). If it fails to do so, it is difficult to provide the PSTs, who are candidates for English language teaching, with a teaching experience which can help them teach English professionally at the school level. If the PSTs lack experience in using devices in a language laboratory, for instance, they may find it difficult to assist their future students to do so. This proves that improvement with regard to the quality of teaching practices as well as learning resources is essential in order that positive outcomes of the pedagogical practices of an educational institution can be facilitated.

The other strategy that the lecturers used when dealing with the oral communication challenges of their PSTs was using strategies for extending speaking turns. This strategy consisted of two sub-strategies, namely, asking for clarification and memorising a set of vocabulary. In the context of the present study, asking for clarification reflects immediate assistance by the lecturers to repair communication breakdown between the lecturers and the PSTs. The strategy is more related to the lecturers' strategy in eliciting correct answers (or an intended meaning) from the PSTs than enabling the PSTs to learn how to bridge gaps in their L2 oral communication. The interviews with some of the participating lecturers indicated that asking for clarification was used as a strategy that the lecturers chose to handle communication difficulties during the PSTs' individual presentation and PSTs-lecturers interaction. This strategy, in fact, may lead to the concept of the "negotiation of meaning", as described by Macaro (2003), through which acquisition of new L2 structures for improved oral skills can be facilitated.

Little is learnt from the lecturers about whether or not they encouraged their PSTs to learn how to clarify their intended meanings when they encountered linguistic difficulty. Asking for clarification requires the skill of paraphrasing words, phrases or structures. It is a commonly used strategy that L1 speakers use to bridge gaps in L1 communication, but may not be so in L2 communication due to the various states of L2 speakers' interlanguage system. The strategy of asking for clarification was reviewed in Azian et al. (2011) and Todd (2005). Azian et al. (2011), for instance, found that the participating teachers employed the strategy to request clarification of their students' preceding utterances. Given this, the students being asked for a clarification were encouraged to use paraphrasing.

Although the lecturers of the present study claimed that they encouraged the PSTs to search for an appropriate word, phrase or structure, the PSTs would perhaps encounter difficulties doing so as they might lack the ability to paraphrase, a key skill in asking for clarification as part of OCS (Todd, 2005). This suggests that the PSTs might also lack some form of assistance in paraphrasing which enables them to search for alternative ways of expressing their ideas despite their vocabulary deficiency. Teachers, through teaching a specific lesson, can provide the assistance, or peers in the form of pair/group which focuses on activities that promote oral communication skills.

In addition to the use of asking for clarification, two of the lecturers in the present study reported that they encouraged their PSTs to memorise vocabulary to help them develop their oral communication skills. Their perceptions agree with that of Lightbown and Spada (2013) who suggest that having adequate L2 vocabulary helps L2 learners to carry out effective L2 oral communication. Yet, in the present study, not all of the lecturers explicitly showed concern over the use of this strategy, but this does not mean that they had no concerns at all. Some of the lecturers view the challenges as generally caused by a lack of practice and low level of self-confidence, whereas others point out the influence of limited linguistic competence, such as poor vocabulary mastery, as the ultimate contributing factors. Given that they had different views, the way they approach the solutions to the problem is also different.

Memorising a set of vocabulary is highlighted by many researchers as a strategy that language learners can choose to improve their communication skills (e.g. Balcı & Çakir, 2011; Vo, 2016). This improvement can be seen by, for instance, the extensive uses of vocabulary that a learner performs. As language teachers, improving students' vocabulary can be part of the lecturer teaching syllabuses, that is, by explicitly teaching it. For example, a teacher may want to ask students to memorise a set of vocabulary specifically used in academic presentation.

Overall, the findings of the present study suggested that the lecturers' responses pertaining to techniques and strategies used to handle PSTs English oral communication challenges can be grouped into two approaches: short and long term strategies. Short-term strategies are used in order to provide immediate assistance for

learners during their communicative activities in the classroom. This assistance can come from their peers or their teachers. A learner who has difficulty finding the right words in English might seek help by asking their peers using English or their first language, or they can consult the dictionary. Even though they may not always get what they want when asking their peers or consulting the dictionary, the learners can become more aware of how to deal with this kind of oral communication challenge. In fact, 'asking their peers', when it is done in English, is one principle for effective oral communication practice in foreign language classroom (Ortega, 2007) and an important social interaction that facilitates L2 learning (Macaro, 2013). Short-term strategies enable these learners to gain help from available resources that surround them in the classroom context.

Short-term strategies, which include setting up classroom activities, setting up group work, tolerating and encouraging the use of L1, and asking for clarification, have sub-strategies. These are teacher guided short-term strategies (tolerating and encouraging the use of L1 and asking for clarification), and non-teacher guided short-term strategies (setting up classroom activities and group work). The similarity of these two sub-groups is that they create an opportunity for the PST to manage their own learning and to select the most appropriate actions for their learning, (Griffiths, 2015). In fact, when they are consciously aware of a range of such actions, their L2 learning can be facilitated (Cohen, 2014). The difference, on the other hand, lies in the degree of the lecturers' involvement in guiding the PSTs when the PSTs attempt to get their messages across during their interaction in English. In the non-teacher guided short-term strategy uses, the PSTs can help themselves overcome English oral communication challenges that they have (e.g. linguistic proficiency challenges) by seeking help from their group members, which they cannot do in the former strategy uses, where help is mostly only available from interacting with the lecturers (e.g. using the Indonesian language).

5.4 Lecturers' encouragement for PSTs to use English oral communication strategies in and out of lectures

The findings show that none of the lecturers specifically mentioned OCS in their efforts to develop their PSTs' English oral communication skills. This indicates two

things. First, the lecturers may not be fully aware of OCS because of a lack of formal training. Second, they may not think teaching OCS, if they were aware of them, are useful for their PSTs' language learning and future educational careers as language teachers. For the majority of these lecturers, as the findings revealed, they might not think of meaning negotiation, which characterises OCS, as a part of the strategies that they can teach their PSTs to help them to find ways of dealing with communication breakdowns in their L2 communication. Instead, they perceive that other strategies, such as setting up classroom activities, setting up group work, tolerating and encouraging the use of L1, encouraging independent learning and using strategies for extending speaking turns can help the PSTs find ways to continue speaking in L2. In educational settings, such as on the English Education Program, ensuring that the PSTs are able to develop any skills pertaining to their language learning is, in fact, imperative (Lightbown & Spada, 2013).

It is worth pointing out here that it seems that the lecturers focus on training their PSTs to develop their production strategies. In production strategies, L2 learners rarely focus on using strategies to negotiate meaning, but try to express ideas in the L2 (Tarone, 1981). A variety of classroom activities, as seen from the syllabuses that the lecturers were using, the interview transcripts analysis, and the data gathered from classroom observations, showed that the PSTs had little exposure to activities which can promote skills in managing L2 communication breakdowns, as part of their oral communication strategies. Despite working in groups, there is no guarantee that when the group members communicate using English and misunderstanding occurs, that they would try to solve it using any of the OCS strategies, nor would they strive to maintain their involvement in such an L2 conversation. In fact, as seen from the classroom observations, many PSTs preferred using Indonesian when working in groups to English. Although there was some evidence of English being used in the group work, this was predominantly from those PSTs with a good level of English speaking skills.

Therefore, it can be said that OCS has not yet become part of the lecturers' teaching practices in the context of the English Education Program. The fact that OCS provide ways for language learners to survive in communication using an L2, and enhance the quality of such communication, may not be fully realised by the lecturers due to

two potential reasons, namely, a lack of formal training in OCS and different perspectives of teaching oral communication skills for the listening and speaking classes.

5.5 Summary

This chapter has discussed the four guiding questions, and related the findings to previous relevant literatures as well as the underpinning theories. There appear to be two potential reasons why OCS instruction were not part of the lecturers' classroom pedagogy. These reasons are also attributed mainly to the lecturers' objectives in teaching, how they perceived challenges in oral communication, as well as what strategies they considered as helpful to tackle the challenges.

Chapter 6

Conclusion

This chapter presents, first, a review of the key findings of the research, and the limitations of those findings. Second, it considers the pedagogical implications of these findings (including recommendations). Third, it outlines the implications for further research. The chapter concludes with a brief summary of the preceding sections.

6.1 Overview of key findings

This study widened out from the initial research questions on OCS instruction on an English Education Program in Indonesia. The main reason for this was that the lecturers had little to say about OCS instruction and whether or not the instruction could be relevant to the curriculum of English Education Program and useful for the PSTs' development of English oral communication skills. The lecturers lacked adequate understanding of OCS (e.g. types and functions), as well as awareness of its instruction with regard to OCS relevance and usefulness to the English Education Program and the PSTs. OCS instruction was not a major part of the lecturers' teaching practices for a number of reasons. First, the majority of the lecturers had a unique understanding of the underlying causes for the existence of the continuously occurring English oral communication breakdowns that challenged EFL learners in the English Education Program. In fact, the lecturers' understandings about OCS were different from those of other OCS scholars (e.g. Dörnyei, 1995; Tarone, 1981). Teaching OCS was not seen by the lecturers as having a direct relationship with the lecturers' effort in handling the English oral communication breakdowns.

The causes for such oral communication breakdowns, as the lecturers reported, were categorised into four different challenges: linguistic proficiency, psychological aspects, English language engagement opportunities, and background knowledge. All these challenges were related to various issues, such as previous English language tuition and exposure to English use during high school study, self-reported lecturers' competence, teaching methodologies and resources, and PSTs' confidence in speaking English. All these issues were interrelated. Proposing a one-size-fits-all strategy as a solution to deal with improving PSTs' oral proficiency level may not be

feasible for the lecturers to apply. In fact, the lecturers seemed to put aside the potential benefits of providing their PSTs with some practical tools that the PSTs could learn and apply to boost their English oral communication skills in different communicative discourses.

The lecturers considered the communication breakdowns as mainly caused by what Dörnyei and Scott (1997, p. 183) called “own-performance problems”, disregarding “other-performance problems” and “processing time pressure”. In other words, the source of the communication challenges that the lecturers perceived was from within the PSTs themselves. This perception clearly explained why the instruction of negotiation strategies’ seemed to be neglected. Indeed, the lecturers appeared to draw heavily on strategies that basically encouraged the learners to find the most appropriate strategies by themselves, by setting up classroom activities and group work, and encouraging independent learning. In other words, the conventional oral communication class that the lecturers taught, perhaps, did not fully accommodate interactive skills, and the lecturers themselves did not have any initiative to vary the convention.

Not all lecturers were unaware of the existing concept of OCS, however. Some of them reported the use of L1 and asking for clarification and memorising a set of vocabulary as techniques and strategies that their PSTs could use to improve their oral communication skills, although little could be elicited from the lecturers about how to best implement these strategies. Using these perceived strategies to cope with English oral communication challenges is the second reason why OCS instruction was not an important part of the lecturers’ teaching practices.

The third reason why teaching the PSTs to negotiate meaning was not part of the lecturers’ pedagogy was that possibly the teaching practices in English oral communication classes in Indonesia did not, by and large, address adequate classroom activities which promote interactive communication skills that reflect everyday life. Engaging in real-life based activities may help language learners to develop their oral proficiency levels and to deal with language anxiety arising from speaking in L2 (Jones, 2004), as they have access to meaningful interactive oral communication (Harmer, 2007). In the English Education Program, many of the

observed classroom activities focused on enabling the PSTs to develop a one-way communication skill, such as individual oral presentations, during which each PST talked about a particular subject. Meanwhile, the listening classes observed did not give much opportunity for the PSTs to enhance their English language listening skills so that they could improve the way they participated in communicative classroom activities in the speaking class. This situation contradicted the objectives of the courses and the purpose of many given classroom activities stipulated in the teaching syllabuses.

This study indicated that the lecturers' objectives in teaching English oral communication were related to the decisions that the lecturers made in teaching their English oral communication classes. Very little could be understood from the lecturers regarding the need to improve PSTs' skills in managing English oral communication breakdowns by, for example, practicing negotiating meaning or paraphrasing. The dominant responses related to the objectives were to improve the PSTs' English language speaking and listening skills in a general sense, as well as developing their confidence in speaking English. In addition, teaching English oral communication skills, for some of the lecturers, was considered as a useful way for them to improve their own English oral proficiency level. It was also found that helping the PSTs to pass the oral component of the TOEFL was another important objective of the lecturers.

The findings of the present study showed that teaching OCS is not a major part of the lecturers teaching practices in the context of the English Education Program in Indonesia. This is not to say that the lecturers consider the strategies instruction less useful than some of the strategies aforementioned, or irrelevant to the context of English language teaching. The lecturers have their own understandings of what objectives in teaching oral communication they want to achieve, what causes the continuously occurring oral communication challenges among the PSTs and how they handle them. In other words, they hold a slightly different understanding of the concept of OCS instruction as compared to the literature identified in this present study. This understanding may shed light on OCS instruction, in particular, on the application of the well-known strategic competence theory in EFL settings.

6.2 Pedagogical implications and recommendations

The lecturers' reports on linguistic proficiency and psychological aspects of the oral communication challenges of the PSTs suggests a need for some review of the curriculum. It is suggested that some parts of OCS may be suitable for teaching in oral communication classes in order to help the PSTs find additional ways to improve the quality of their English oral communication, especially when it comes to meaning negotiation and self-repair. For this purpose, Lam (2010) proposes OCS education, particularly for low proficient English language learners, who can be more receptive to certain OCS use than high proficient learners. Canale and Swain (1980) point out the importance of such OCS education for beginner language learners. Adding some OCS instruction to the existing curriculum used in the English Education Program might benefit the PSTs with carrying out individual oral presentations or conversation in English.

In teaching OCS in the classroom, teachers can follow the phases as suggested by Maleki (2007):

1. Engaging learners in a discussion of their language learning processes, approaches, needs and learning resources that they can find outside the classroom.
2. Teaching particular OCS which suits learners' learning approaches or needs.
3. Providing learners with some activities that can stimulate learners to use OCS and encouraging them to be aware of specific strategies that they can use in specific oral communication contexts.

The findings also suggested that the English Education Program may need to carry out an evaluation of the teacher education program, especially in the area of teaching oral communication skills. Despite being successfully enrolled into the program, many of the PSTs who graduated from the surrounding high schools continued to face issues related to oral English communication for various reasons. These issues are also faced by many university students majoring in English language in Asia, such as in Japan (Bekleyen, 2009) and Palestine (Alyan, 2013). As an institution that prepares English teacher candidates for ELT praxis, the English Education Program might benefit from developing an awareness of psychological challenges, which can

compromise successful English language learning. Other dimensions, such as lecturers' competency, teaching and learning resources, and the current English education curriculum may need to be re-examined to find gaps that might make it difficult for the program's stated goals to be achieved.

The fact that the English Education Program prepares English language teachers with both pedagogical and language skills helps to continuously build the PSTs' positive attitude about learning English as a foreign language. It is necessary for the English Education Program to continuously develop a specific "conceptual framework of reference" to provide PSTs with skills and knowledge relevant to their future teaching practises (Zein, 2014, p. 12). This can be done by introducing the notion of OCS to English oral communication classes and several relevant courses, such as English for Specific Purposes, English for Young Learners, Teaching English as a Foreign Language, and Sociolinguistics. These courses may also equip the PSTs with a belief that successful language learning is an achievable task, and that having a positive attitude towards such a task is crucial. In fact, providing the PSTs with tools that can accelerate their learning by continuously practicing communicating in English, such as OCS, could be useful for their English language acquisition.

In addition to promoting a positive attitude and providing OCS instruction, the lecturers need to reflect on their teaching practices, especially how they build good relationships with their PSTs. As lecturers, their role is vital. Renandya (2012) believes that for successful language learning to take place, one of the most important factors that teachers need to take into account is their ability to play different roles, such as instructor, motivator and prompter in different learning situations. In addition, the lecturers may also want to simultaneously examine relevant research pertaining to the psychological and socio-cultural issues because, as Dobinson (2012) maintained, such issues may be caused by different factors, such as language proficiency and the context in which the language is used, which can lead to passivity in the classroom.

At the same time, secondary schools also need to constantly take responsibility to ensure that their students have an adequate experience of using the language they learn for various communication purposes during their study. This is because the

classroom should not be regarded as the primary or only source for communication. There are a wide range of learning opportunities for students outside the classroom (Richards, 2015). When classroom learning activities help the students become motivated and aware of the availability of a wide range of learning opportunities around them, adequate exposure to English can be made available for them at an earlier time. To do this, as Mercieca (2014) suggested, classroom activities may not always be prescribed by teachers per se, but by negotiating them with the learners.

6.3 Implications for further research

This present study was confined by the limited responses of the lecturers pertaining to their perspectives on OCS instruction on the English Education Program. It has shown that the lecturers may not fully embrace teaching OCS in their teaching practices. The responses to the four additional research questions have indicated that the bulk of this preliminary conclusion is attributed to the lecturers' objectives in teaching oral communication, their understanding of the English oral communication challenges, the techniques and strategies they use to handle the challenges, and whether or not they encourage their PSTs to use OCS. Responses to these four questions will explain how EFL lecturers take instruction in OCS into account.

However, the present study did not address the perspectives of other lecturers who were teaching other coursework units, such as English for Young Learners, Sociolinguistics, Teaching English for Young Learners, or units in the literature category, such as Introduction to Literature, Drama and Poetry. Further research that investigates these lecturers' perspectives on OCS instruction would likely bring about different points of view. At the theoretical level, the research may be focused on exploring the lecturers' perspective of OCS instruction, its relevance to particular coursework or the curriculum of DEE in general, and its applicability in the classroom. At the practical level, for example, the research may look at how OCS instruction operates in the classroom, what function OCS use has on lecturers and PSTs, and how its instruction may be improved in the classroom. Data for this further research could be supplemented by focus group interviews, which could be conducted prior to doing individual interviews. This would help researchers develop

interview questions based on the interviewees' responses, and functions as stimulated recall interviews.

Other further research might also focus on the PSTs. At the theoretical level, the research might explore the PSTs' understanding of the concept of OCS and the reasons why they learn or do not learn OCS. At the practical level, the research may investigate the PSTs' individual experiences in learning and using OCS in and outside classes, as well as examine what functions particular OCS have on PSTs. Findings generated from this further research could allow insights from the different points of view of the respondents who are English language teacher candidates at the school level and also professionals in other fields or occupations, and the data may be collected by group interviews or individual interviews, journal writing, and/or observation.

References

- Aghazadeh, S., & Abedi, H. (2014). Student reticence in Iran's academia: Exploring students' perceptions of causes and consequences. *Procedia - Social and Behavioral Sciences*, 98, 78-82. doi:10.1016/j.sbspro.2014.03.391
- Alyan, A.A. (2013). Oral communication problems encountering English major students: Perspectives of learners and teachers in Palestinian EFL university context. *Arab World English Journal*, 4(3), 226-238. Retrieved from <http://www.awej.org>
- Færch, C., & Kasper, G. (1983a). Plans and strategies in foreign language communication. In C. Færch & G. Kasper (Eds.), *Strategies in interlanguage communication* (pp. 20 - 60). Harlow, England: Longman.
- Anderson, C. E., McDougald, J. S., & Cuesta Medina, L. (2015). CLIL for young learners. In C. N. Giannikas, L. McLaughlin, G. Fanning, & N. D. Muller (Eds.), *Children learning English: From research to practice* (pp. 137 – 151). UK: Garnet education.
- Anwar, K. (2016). Panel discussion and the development of students' self confidence. *English Language Teaching*, 9(4), 224. doi: 10.5539/elt.v9n4p224
- Apple, M. W., Au, W., & Gandin, L. A. (2009). *The Routledge international handbook of critical education*. London: Routledge.
- Avinash, M. R. (2016). Use of puzzle solving games to teach English. *Indian Journal of Science and Technology*, 9(15). doi: 10.17485/ijst/2016/v9i15/86940
- Azian, A. A., Abdul Raof, A. H., Ismail, F., & Hamzah, M. (2013). Communication strategies of non-native speaker novice science teachers in second language science classrooms. *System*, 41(2), 283-297. Retrieved from <http://www.sciencedirect.com.dbgw.lis.curtin.edu.au>
- Baker, S. C. & MacIntyre, P. D. (2003). The role of gender and immersion in communication and second language orientations. *Language Learning Journal*, 53, 65-96. doi: 10.1111/0023-8333.00119
- Banegas, D. L. (2015). Sharing views of CLIL lesson planning in language teacher education. *Latin American Journal of Content & Language Integrated Learning*, 8(2), 104-130.
- Bax, S. (2003). The end of CLT: A context approach for language teaching. *ELT Journal*, 57(3), 278-287. doi: 10.1093/elt/57.3.278
- Balçı, Ö., & Çakir, A. (2011). Teaching vocabulary through collocations in EFL Classes: The case of Turkey. *International Journal of Research Studies in Language Learning*, 1(1), 21-32.

- Bedir, H. (2010). Teachers' beliefs on strategies based instruction in EFL classes of young learners. *Procedia - Social and Behavioral Sciences*, 2(2), 5208-5211. Retrieved from <http://www.sciencedirect.com.dbgw.lis.curtin.edu.au>
- Bekleyen, N. (2009). Helping teachers become better English students: Causes, effects, and coping strategies for foreign language listening anxiety. *System*, 37, 664-675. doi: 10.1016/j.system.2009.09.010
- Bialystok, E. (1990). *Communication Strategies*. Oxford: Blackwell.
- Borg, S. (2003). Teacher cognition in language teaching: A review of research on what language teachers think, know, believe, and do. *Language Teaching*, 36(2), 81-109. Retrieved from <http://eprints.whiterose.ac.uk>
- Brett, A. G. (2001). Teaching communication strategies to beginners. *The Language Learning Journal*, 24(1), 53-61. Retrieved from <http://www.tandfonline.com.dbgw.lis.curtin.edu.au>
- Brumfit, C. (1981). Teaching the 'general' student. In K. Johnson & K. Morrow (Eds.), *Communication in the classroom* (pp. 46-51). England: Longman Group Ltd.
- Bryman, A. (2012). *Social research methods* (4th ed.). Oxford: Oxford University Press.
- Burns, A., & Richards, J. C. (Eds.). (2009). *The Cambridge guide to second language teacher education*. Cambridge: Cambridge University Press.
- Canagarajah, S. (2007). Lingua franca English, multilingual communities, and language acquisition. *Modern Language Journal*, 91(5), 923-939. Retrieved from <http://onlinelibrary.wiley.com.dbgw.lis.curtin.edu.au>
- Canagarajah, S., & Ashraf, H. (2013). Multilingualism and Education in South Asia: Resolving policy/practice dilemmas. *Annual Review of Applied Linguistics*, 33, 258-285. doi: 10.1017/S0267190513000068
- Canale, M., & Swain, M. (1980). Theoretical bases of communicative approaches to second language teaching and testing. *Applied linguistics*, 1(1), 1-47. Retrieved from <http://applied.oxfordjournals.org.dbgw.lis.curtin.edu.au>
- Canan Hänsel, E. V. A., & Deuber, D. (2013). Globalization, postcolonial Englishes, and the English language press in Kenya, Singapore, and Trinidad and Tobago. *World Englishes*, 32(3), 338-357. doi: 10.1111/weng.12035
- Caron, J. (1992). *An introduction to psycholinguistics*. New York: Harvester Wheatsheaf.
- Chamot, A. U. (2004). Issues in language learning strategy research and teaching. *Electronic journal of foreign language teaching*, 1(1), 14-26. Retrieved from <http://e-flt.nus.edu.sg/v1n12004/chamot.pdf>

- Chamot, A. U. (2005). Language learning strategy instruction: Current issues and research. *Annual Review of Applied Linguistics*, 25, 112-130. Retrieved from <http://search.proquest.com.dbgw.lis.curtin.edu.au>
- Channa, L. A., & Soomro, N. H. (2015). Content-based instruction: A novel second/foreign language curricular approach. *NUML Journal of Critical Inquiry*, 13(1), 1. Retrieved from <http://search.proquest.com.dbgw.lis.curtin.edu.au>
- Chen, J., Brown, G. T. L., Hattie, J. A. C., & Millward, P. (2012). Teachers' conceptions of excellent teaching and its relationships to self-reported teaching practices. *Teaching and Teacher Education*, 28(7), 936-947. Retrieved from <http://www.sciencedirect.com.dbgw.lis.curtin.edu.au>
- Cheng, C. M. (2012). The influence of college EFL teachers' understandings of intercultural competence on their self-reported pedagogical practices in Taiwan. *English Teaching*, 11(1), 164. Retrieved from <http://search.proquest.com.dbgw.lis.curtin.edu.au>
- Cheng, X. (2000). Asian students' reticence revisited. *System*, 28, 435-446. doi:10.1016/S0346-251X(00)00015-4
- Clark, H. H. (1994). Managing problems in speaking. *Speech Communication*, 15(3-4), 243-250. Retrieved from <http://www.sciencedirect.com.dbgw.lis.curtin.edu.au>
- Cohen, A. D. (2005). Strategies for learning and performing L2 speech acts. *Intercultural Pragmatics*, 2(3), 275-301. Retrieved from <https://www-degruyter-com.dbgw.lis.curtin.edu.au>
- Cohen, A. D. (2014). *Strategies in learning and using a second language*. New York: Routledge.
- Coyle, D. (2007). Content and language integrated learning: Towards a connected research agenda for CLIL pedagogies. *International Journal of Bilingual Education and Bilingualism*, 10(5), 543-562.
- Coyle, D., Holmes, B., and King, L. (2009). Towards an integrated curriculum-CLIL National Statement and Guidelines. Retrieved from <http://www.rachelhawkes.com/PandT/CLIL/CLILnationalstatementandguidelines.pdf> [accessed 8.2.2013].
- Crandall, J. J. (2000). Language teacher education. *Annual Review of Applied Linguistics*, 20, 34-55. Retrieved from <http://journals.cambridge.org.dbgw.lis.curtin.edu.au>
- Creswell, J. W. (2012). *Educational research: planning, conducting, and evaluating quantitative and qualitative research*. Boston, MA: Pearson.
- Crystal, D. (2003). *English as a global language* (2nd ed.). Cambridge: Cambridge University Press.

- Dardjowidjojo, S. (2003). *Rampai Bahasa, pendidikan, dan budaya*. Jakarta: Yayasan Obor Indonesia.
- Denzin, N. K., & Lincoln, Y. S. (Eds.). (2003). *The landscape of qualitative research: Theories and issues* (2nd ed.). Thousand Oaks, CA: Sage.
- Departemen Pendidikan Nasional (Department of National Education). (2005). Peraturan Pemerintah Republik Indonesia No. 19/2005 Tentang Standar Nasional Pendidikan [The Decree of Government of Republic of Indonesia No. 19/2005 on National Standard of Education]. Jakarta: Kementrian Pendidikan Nasional.
- Departemen Pendidikan Nasional (Department of National Education). (2003). Undang-Undang No. 20/2003 Tentang Sistem Nasional Pendidikan [The Law of Republic of Indonesia No. 20/2003 on National System of Education]. Jakarta: Kementrian Pendidikan Nasional.
- Departemen Pendidikan Nasional (Department of National Education). (2005). Undang-Undang No. 14/2005 Tentang Guru dan Dosen [The Law of Republic of Indonesia No. 14/2005 on Teachers and Lecturers]. Jakarta: Kementrian Pendidikan Nasional.
- Derwing, T. M., & Munro, M. J. (2005). Second language accent and pronunciation teaching: A research-based approach. *TESOL Quarterly*, 39(3), 379-397. Retrieved from <http://www.jstor.org.dbgw.lis.curtin.edu.au>
- Dobinson, T. (2012). Out of Asia: Learning re-examined, teacher education re-configured. *Asia Pacific Journal of Education*, 32(2), 167-179. doi: 10.1080/02188791.2012.685234
- Donato, R. (2000). Sociocultural contributions to understanding the foreign and second language classroom. In J. P. Lantolf (Ed.), *Sociocultural theory and second language learning* (pp. 27-50). New York: Oxford University Press.
- Du, Y. (2016). *The use of first and second language in Chinese university EFL classrooms*. Singapore: Springer.
- Dörnyei, Z. (1995). On the teachability of communication strategies. *TESOL Quarterly*, 29(1), 55-85. Retrieved from <http://www.jstor.org.dbgw.lis.curtin.edu.au>
- Dörnyei, Z. & Scott, M. L. (1997). Communication strategies in a second language: Definitions and taxonomies. *Language Learning*, 47(1), 173-210. doi: 10.1111/0023-8333.51997005
- Ehrman, M. E., Leaver, B. L., & Oxford, R. L. (2003). A brief overview of individual differences in second language learning. *System*, 31(3), 313-330. doi: 10.1016/S0346-251X(03)00045-9

- Ellis, R. (2003). *Task-based language learning and teaching*. Oxford, New York: Oxford Applied Linguistics.
- Erlandson, D. L., Harries, E. L., Skipper, B. L., & Allen, S. D. (1993). *Doing naturalistic inquiry: A guide to methods*. Newbury Park, CA: Sage.
- Fareh, S. (2010, 25 January). *Challenges of teaching English in the Arab world: Why can't EFL programs deliver as expected?* Paper presented at the World Conference on Educational Sciences. doi:10.1016/j.sbspro.2010.03.559
- Fatiha, M., Sliman, B., Mustapha, B., & Yahia, M. (2014). Attitudes and motivations in learning English as a foreign language. *International Journal of Arts & Sciences*, 07(03), 117-128. Retrieved from <http://search.proquest.com>
- Fennelly, M., & Luxton, R. (2011). Are they ready? On the verge of compulsory English, elementary school teachers lack confidence. *The Language Teacher*, 35(2), 19-24. Retrieved from <http://www.jalt-publications.org>
- Field, J. (2003). *Psycholinguistics: A resource book for students*. London: Routledge.
- Firman, H., & Tola, B. (2008). The future of schooling in Indonesia. *Journal of International Cooperation in Education*, 11(1), 71-84.
- Freeman, D. (2009). The scope of second language teacher education. In A. Burns & J. C. Richards (Eds.), *The Cambridge guide to second language teacher education* (pp.11-19). Cambridge: Cambridge University Press.
- Freire, P. (1998). *Pedagogy of freedom: Ethics, democracy, and civic courage*. Lanham MD: Rowman and Littlefield Publishers.
- Færch, C., & Kasper, G. (1983a). Plans and strategies in foreign language communication. In C. Færch & G. Kasper (Eds.), *Strategies in interlanguage communication* (pp. 20 - 60). Harlow, England: Longman.
- Furaidah., Saukah, A., & Widiati, U. (2015). Washback of English national examination in the Indonesian context. *TEFLIN Journal*, 26(1), 36-58. doi:10.15639/teflinjournal.v26i1/36-58
- García Mayo, M. P., & Ibarolla, A. L. (2015). Do children negotiate for meaning in task-based interaction? Evidence from CLIL and EFL settings. *System*, 54, 40-54. doi: 10.1016/j.system.2014.12.001
- Georgiou, S. I. (2012). Reviewing the puzzle of CLIL. *ELT journal*, 66(4), 495-504. doi:10.1093/elt/ccs047
- Ghorbani, A. (2011). *First language use in foreign language classroom discourse*. Paper presented at the International Conference on Education and Educational Psychology. doi: 10.1016/j.sbspro.2011.11.408

- Ghout-Khenoune, L. (2012). The effects of task type on learners' use of communication strategies. *Procedia - Social and Behavioral Sciences*, 69, 770 – 779. doi: 10.1016/j.sbspro.2012.11.472
- Gillies, R. M. (2016). Cooperative learning: Review of research and practice. *Australian Journal of Teacher Education*, 41(3), 39-54. doi: 10.14221/ajte.2016v41n3.3
- Giroux, H. A. (1989). Schooling as a form of cultural politics: Toward a pedagogy of and for difference. In Giroux, H. A. and McLaren (Eds.), *Critical pedagogy, the State, and Cultural Struggle* (pp. 125-151). Albany, NY: SUNY Press.
- González Humanez, L. E., & Arias, N. (2009). Enhancing oral interaction in English as a foreign language through task-based learning activities. *Latin American Journal of Content & Language Integrated Learning*, 2(2), 1-9. doi:10.5294/lacil.2009.2.2.10
- Gordon, R. G. (2005). *Ethnologue: Languages of the world*. Dallas: SIL International.
- Griffiths, C. (2015). What have we learnt from 'good language learners'? *ELT Journal*, 69(4), 425-433. doi: 10.1093/elt/ccv040
- Hamied, F. A. (2012). English in multicultural and multilingual Indonesian education. In *English as an international language in Asia: Implications for language education* (pp. 63-78). Springer Netherlands.
- Harmer, J. (2007). *The practice of English language teaching* (4th ed.). Harlow: Longman.
- Hayes, D. (2009). Non-native English-speaking teachers, context and English language teaching. *System*, 37, 1-11. doi: 10.1016/j.system.2008.06.001
- Hinkel, E. (2006). Current perspectives on teaching the four skills. *TESOL Quarterly*, 40(1), 109-131. Retrieved from <http://www.jstor.org.dbgw.lis.curtin.edu.au>
- Howatt, A. P. R., & Widdowson, H. G. (2004). *A history of English language teaching* (2nd ed.). Oxford: OUP.
- Huong, L. P. H. (2007). The more knowledgeable peer, target language use, and group participation. *The Canadian Modern Language Review*, 64(2), 333-354. Retrieved from www.muse-jhu-edu.dbgw.lis.curtin.edu.au
- Hymes, D. (1972). On communicative competence. In J. B. Pride and J. Holmes (Eds.), *Sociolinguistics* (pp. 269 – 293). Harmondsworth: Penguin.
- Jamshidnejad, A. (2011). Functional approach to communication strategies: An analysis of language learners' performance in interactional discourse. *Journal of Pragmatics*, 43, 3757-3769. doi: 10.1016/j.pragma.2011.09.017

- Jenkins, J. (2003). *World Englishes*. London: Routledge.
- Jenks, C. J., & Lee, J. W. (2016). Heteroglossic ideologies in world Englishes: An examination of the Hong Kong context. *International Journal of Applied Linguistic*, doi: 10.1111/ijal.12135
- Johnson, D., & Johnson, F. (2009). *Joining together: Group theory and group skills* (10th ed.). Upper Saddle River, N.J: Pearson Education.
- Jones, J. F. (2004). A cultural context for language anxiety. *English Australia Journal*, 21(2), 30-39. Retrieved from <http://search.informit.com.au.dbgw.lis.curtin.edu.au>
- Kachru, B. B. (1990). World Englishes and applied linguistics. *World Englishes*, 9(1), 3-20. doi: 10.1111/j.1467-971X.1990.tb00683
- Kagan, D. M. (1990). Ways of evaluating teacher cognition: Inferences concerning the Goldilocks principle. *Review of Educational Research*, 60(3), 419-469. Retrieved from <http://citeseerx.ist.psu.edu/>
- Kam, H. W. (2002). English language teaching in East Asia today: An overview. *Asia Pacific Journal of Education*, 22(2), 1-22. doi:10.1080/0218879020220203
- Kayi-Aydar, H. (2013). Scaffolding language learning in an academic ESL classroom. *ELT Journal*, 67(3), 324-335. doi: 10.1093/elt/cct016
- Khamkhien, A. (2010). Teaching English speaking and English speaking tests in the Thai context: A reflection from Thai perspective. *English Language Teaching*, 3(1), 184-190. Retrieved from <http://search.proquest.com.dbgw.lis.curtin.edu.au>
- Kellerman, E. (1991). Compensatory strategies in second language research: A critique, a revision, and some (non-) implications for the classroom. In R. Phillipson, E. Kellerman, L. Selinker, M. S. Smith & M. Swain (Eds.), *Foreign/second language pedagogy research: A commemorative volume for Claus Faerch* (pp. 142-161). Clevedon, England: Multilingual Matters.
- Kirkpatrick, A. (2008). English as the official working language of the Association of Southeast Asian Nations (ASEAN): Features and strategies. *English Today*, 24(2), 27-34. Retrieved from <http://media.proquest.com.dbgw.lis.curtin.edu.au>
- Kirkpatrick, A. (2007). *World Englishes: Implications for international communication and English language teaching*. Cambridge: Cambridge University Press.
- Klanrit, P., & Sroinam, R. (2012). EFL teacher's anxiety in using English in teaching in the language classroom. *International Journal of Social Science and Humanity*, 2(6), 493.

- Klimova, B. F. (2015). *Games in the teaching of English*. Paper presented at the World Conference on Educational Sciences. doi: 10.1016/j.sbspro.2015.04.312
- Krashen, S. (1982). *Principles and practice in second language acquisition*. Oxford: Pergamon.
- Kumaravadivelu, B. (2001). Toward a postmethod pedagogy. *TESOL Quarterly*, 35(4), 537-560.
- Kumaravadivelu, B. (2003). Critical language pedagogy: A postmethod perspective on English language teaching. *World Englishes*, 22(4), 539-550. doi:10.1111/j.1467-971X.2003.00317.x
- Kurihara, Y., & Samimy, K. K. (2007). The impact of a U.S. teacher training program on teaching beliefs and practices: A case study of secondary school level Japanese teachers of English. *JALT Journal*, 29(1), 99-122. Retrieved from <http://www.jalt-publications.org>
- Lam, W. Y. (2010). Implementing communication strategy instruction in the ESL oral classroom: What do low-proficiency learners tell us? *TESL Canada Journal*, 27(2), 11. doi: 10.18806/tesl.v27i2.1056
- Lamb, M., & Coleman, H. (2008). Literacy in English and the transformation of self and society in post-Soeharto Indonesia. *International Journal of Bilingual Education and Bilingualism*, 11(2), 189-205. Retrieved from <http://www-tandfonline-com.dbgw.lis.curtin.edu.au>
- Lantolf, J. P. (1994). Sociocultural theory and second language learning: Introduction to the special issue. *The Modern Language Journal*, 78(4), 418-420.
- Lap, T. Q. (2005). *Stimulating learner autonomy in English language education: A curriculum innovation study in a Vietnamese context*. Amsterdam: PrintPartnerIpskamp.
- Larsen-Freeman, D. & Long, M.H. (1991). *An introduction to second language acquisition research*. Longman: London.
- Lauder, A. (2008). The status and function of English in Indonesia: A review of key factors. *MAKARA Seri Sosial Humaniora*, 12(1), 9-20. Retrieved from <http://repository.ui.ac.id>
- Leinhardt, G. (1990). Capturing craft knowledge in teaching. *Educational Researcher*, 19(2), 18-25. Retrieved from <http://citeseerx.ist.psu.edu/>
- Lengkanawati, N. S. (2005). EFL teachers' competence in the context of English curriculum 2004: implications for EFL teacher education. *TEFLIN Journal*, 16(1), 79-92.

- Lewis, S. (2011). Are communication strategies teachable? *Encuentro*, 20, 46-54. Retrieved from <http://files.eric.ed.gov/fulltext/ED530010.pdf>
- Lie, A. (2007). Education policy and EFL curriculum in Indonesia: Between the commitment to competence and the quest for high test scores. *TEFLIN Journal*, 18(1), 1-14. Retrieved from <http://journal.teflin.org>
- Lightbown, P. M., & Spada, N. (2013). *How Languages are learned* (4th ed.). Oxford: Oxford University Press.
- Lincoln, Y. S., & Guba, E. G. (1985). *Naturalistic inquiry*. Beverly Hills, Calif: Sage Publications.
- Littlemore, J. (2003). The communicative effectiveness of different types of communication strategy. *System*, 31(3), 331-347. Retrieved from www.sciencedirect.com/dbgw.lis.curtin.edu.au
- Littlewood, W. (2004). The task-based approach: Some questions and suggestions. *ELT Journal*, 58(4), 319-326. doi: 10.1093/elt/58.4.319
- Littlewood, W. (2007). Communicative and task-based language teaching in East Asian classrooms. *Language Teaching*, 40(3), 243-249. doi: 10.1017/S0261444807004363
- Liu, T. Y., & Chu, Y. L. (2010). Using ubiquitous games in an English listening and speaking course: Impact on learning outcomes and motivation. *Computers and Education*, 55, 630-643. doi: 10.1016/j.compedu.2010.02.023
- Lofland, J. (1971). *Analyzing social settings*. Belmont, CA: Wadsworth.
- Long, M. (2014). *Second language acquisition and task-based language teaching*. Oxford, UK: John Wiley & Sons.
- Lowenberg, P. H. (1991). English as an additional language in Indonesia. *World Englishes*, 10(2), 127-138. Retrieved from <http://onlinelibrary.wiley.com/dbgw.lis.curtin.edu.au>
- Lyster, R., & Ballinger, S. (2011). Content-based language teaching: Convergent concerns across divergent contexts. *Language Teaching Research*, 15(3), 279-288.
- Macaro, E. (2003). *Teaching and learning a second language: A guide to recent research and its application*. London: Continuum.
- Macianskiene, N. (2016). Development of transversal skills in content and language integrated learning classes. *European Scientific Journal*, 12(1), 129-139. doi: 10.19044/esj.2016.v12n1p129
- Mackey, A., and S. Gass, (2005). *Second Language Research: Methodology and Design*. London: Lawrence Erlbaum.

- Manara, C. (2007). The use of L1 support: Teachers' and students' opinions and practices in an Indonesian context. *The Journal of Asia TEFL*, 4(1), 145-178. Retrieved from <http://www.researchgate.net>
- Maleki, A. (2007). Teachability of communication strategies: An Iranian experience. *System*, 35, 583-594. doi: 10.1016/j.system.2007.04.001
- Mappiasse, S. S., & Sihes, A. J. B. (2014). Evaluation of English as a foreign language and its curriculum in Indonesia: A review. *English Language Teaching*, 7(10), 113-122. Retrieved from <http://search.proquest.com.dbgw.lis.curtin.edu.au>
- Marcellino, M. (2008). English language teaching in Indonesia: A continuous challenge in education and cultural diversity. *TEFLIN Journal*, 19(1), 57-69. Retrieved from <http://journal.teflin.org>
- Marsh, D. (Ed.). (2002). *CLIL/EMILE The European dimension: Actions, trends and foresight potential public services contract DG EAC*. European Commission.
- Marshal, C., & Rossman, G. B. (1995). *Designing qualitative research* (2nd ed.). Thousand Oaks: Sage Publications.
- Mattarima, K., & Hamdan, A. R. (2011). The teaching constraints of English as a foreign language in Indonesia: the context of school based curriculum. *Sosiohumanika*, 4(2), 287-300.
- Maulana, R., Opdenakker, M. C., Stroet, K., & Bosker, R. (2012). Observed lesson structure during the first year of secondary education: Exploration of change and link with academic engagement. *Teaching and Teacher Education*, 28(6), 835-850.
- McArthur, T. (2003). English as an Asian language. *English Today*, 19(2), 19-22. Retrieved from <http://search.proquest.com.dbgw.lis.curtin.edu.au>
- McKay, S. L. (2003). Toward an appropriate EIL pedagogy: Re-examining common ELT assumptions. *International Journal of Applied Linguistics*, 13(1), 1-22. doi: 10.1111/1473-4192.00035
- Mehisto, P., Marsh, D. & Frigols, M.J. (2008). *Uncovering CLIL: Content and language integrated learning in bilingual education and multilingual education*. Oxford, UK: Macmillan.
- Mercieca, P. D. (2014). Changing perspectives of literacy, identity and motivation: Implications for language education. In K. Dunworth & G. Zhang (Eds.), *Critical perspective on language education: Australia and the Asia Pacific* (pp. 29-48). Cham: Springer.
- Merriam, S. B. (1998). *Qualitative research and case study applications in education*. San Fransisco: Jossey-Bass Publishers.

- Met, M. (1999). *Content-based instruction: Defining terms, making decisions. NFLC Report*. Washington, D.C.: National Foreign Language Center. Retrieved from <http://www.carla.umn.edu/cobaltt/modules/principles/decisions.html>
- Miles, M. B., & Huberman, A. M. (1994). *Qualitative data analysis: An expanded sourcebook* (2nd ed.). Thousand Oaks: Sage Publications.
- Mirzaei, A., & Forouzandeh, F. (2013). Relationship between intercultural communicative competence and L2-learning motivation of Iranian EFL learners. *Journal of Intercultural Communication Research*, 42(3), 300-318. doi: 10.1080/17475759.2013.816867
- Modiano, M. (2009). Inclusive/exclusive? English as a lingua franca in the European Union. *World Englishes*, 28(2), 208-223. doi: 10.1111/j.1467-971X.2009.01584.x
- Moussu, L., & Llorca, E. (2008). Non-native English-speaking English language teachers: History and research. *Language Teaching*, 41(03), 315-348.
- Mukminatien, N. (1999). The problem of developing speaking skills: Limitations of second language acquisition in an EFL classroom. *English Language Education*, 5(1), 1-10.
- Mustafa, B. (2001). Communicative language teaching in Indonesia: Issues of theoretical assumptions and challenges in the classroom practice. *TEFLIN Journal*, 12(2), 184-193. Retrieved from <http://journal.teflin.org/index.php/journal>
- Nakane, I. (2005). Negotiating silence and speech in the classroom. *Multilingua-Journal of Cross-Cultural and Interlanguage Communication*, 24(1-2), 75-100. Retrieved from <http://www.degruyter.com>
- Nakatani, Y. (2012). Exploring the implementation of the CEFR in Asian contexts: Focus on communication strategies. *Procedia - Social and Behavioral Sciences*, 46(0), 771-775. Retrieved from <http://www.sciencedirect.com.dbgw.lis.curtin.edu.au>
- Naves, T. (2009). Effective content and language integrated learning programmes. In Y. Ruiz de Zarobe & R. M. Jimenez Catalan (Eds.), *Content and Language Integrated Learning: Evidence from Research in Europe*. Bristol: Multilingual Matters.
- Nunan, D. (2004). *Task-based language teaching*. Cambridge: Cambridge University Press.
- Nunan, D. (2006). Task-based language teaching in the Asia context: Defining 'task'. *Asian EFL Journal*, 8(3), 12-18. Retrieved from <http://www.asian-efl-journal.com>

- Ohta, A. S. (2000). Rethinking interaction in SLA: developmentally appropriate assistance in the zone of proximal developmental and the acquisition of L2 grammar. In J. P. Lantolf (Ed.), *Sociocultural theory and second language learning* (pp. 51-78). New York: Oxford University Press.
- Omar, H., Embi, M. A., & Yunus, M. M. (2012). Learners' use of communication strategies in an online discussion via Facebook. *Procedia - Social and Behavioral Sciences*, 64(0), 535-544. Retrieved from <http://www.sciencedirect.com.dbgw.lis.curtin.edu.au>
- Oliver, R., & Philp, J. (2014). *Focus on oral interaction*. Oxford: Oxford University Press.
- Ortega, L. (2007). Meaningful L2 practice in foreign language classrooms: A cognitive-interactionist SLA perspective. In R. DeKeyser (Ed.), *Practice in a second language: Perspectives from applied linguistics and cognitive psychology*, 180-207. Cambridge: Cambridge University Press.
- Oxford, R. L. (1990). *Language learning strategies: What every teacher should know*. New York: Newbury House Publisher.
- Oxford, R. L. (2013). *Teaching & researching: Language learning strategies*. New York: Routledge.
- Panggabean, H. (2015). Problematic approach to English learning and teaching: A case in Indonesia. *English Language Teaching*, 8(3), 35.
- Patton, M. Q. (1980). *Qualitative evaluation methods*. Beverly Hills: Sage Publications.
- Pennycook, A. (2014). *The cultural politics of English as an international language*. Hoboken: Taylor and Francis.
- Pennycook, A. (1990). Critical pedagogy and second language education. *System*, 18(3), 303-314.
- Phillipson, R. (2008). The linguistic imperialism of neoliberal empire. *Critical Inquiry in Language Studies*, 5(1), 1-43. Retrieved from <http://www.tandfonline.com.dbgw.lis.curtin.edu.au>
- Phillipson, R. (1992). *Linguistic imperialism*. Oxford: Oxford University Press.
- Polio, C., & Duff, P. (1994). Teachers' language use in university foreign language classrooms: A qualitative analysis of English and target language alternation. *The Modern Language Journal*, 78, 313-326. Retrieved from <http://www.jstor.org.dbgw.lis.curtin.edu.au/>
- Poullisse, N., 1993. A theoretical account of lexical communication strategies. In R. Schreuder & B. Weltens (Eds.), *The Bilingual Lexicon* (pp. 157-189). Amsterdam: John Benjamins Publishing Company.

- Prabhu, N. S. (1987). *Second language pedagogy*. New York: Oxford University Press.
- Qu, Y. (2010). Culture understanding in foreign language teaching. *English language teaching*, 3(4), 58-61.
- Rabab'ah, G., & Bulut, D. (2007). Compensatory strategies in Arabic as a second language. *Poznań Studies in Contemporary Linguistics*, 43(2), 2007, 83-106. doi:10.2478/v10010-007-0020-5
- Rajadurai, J. (2004). The faces and facets of English in Malaysia. *English Today*, 20(4), 54-58. doi:10.1017/S0266078404004109
- Rajagopalan, K. (2004). The context of World English and its implications for ELT. *ELT Journal*, 58(2), 111 – 117. doi: 10.1093/elt/58.2.111
- Rajagopalan, K. (2012). 'World English' or 'World Englishes'? Does it make any difference?. *International Journal of Applied Linguistics*, 22(3), 374-391. doi: 10.1111/j.1473-4192.2012.00316.x
- Renandya, W.A. (2012). Teacher Roles in EIL. *The European Journal of Applied Linguistics and TEFL*, 1(2), 65-80.
- Renandya, W. A., & Farrel, T. S. C. (2011). 'Teacher, the tape is too fast': Extensive listening in ELT. *ELT Journal*, 65(1), 52-59. doi: 10.1093/elt/ccq015
- Rhonda, O., & Philp, J. (2014). *Focus on Oral Interaction: Research-led guide exploring the role of oral interaction for second language learning*. Oxford, UK: Oxford University Press.
- Richards, J.C. (2013). Curriculum approaches in language teaching: Forward, central, and backward design. *RELC Journal*, 44(1), 5-33. Retrieved from <http://rel.sagepub.com.dbgw.lis.curtin.edu.au/>
- Richards, J. C. (2015). The changing face of language learning: Learning beyond the classroom. *RELC Journal*, 46(1), 5-22. doi: 10.1177/0033688214561621
- Roberts, C., Byram, M., Barro, A., Jordan, S., & Street, D. (2001). *Language learners as ethnographers*. Clevedon: Multilingual Matters Ltd.
- Rohani, S. (2011). Impact of task-based learning on Indonesian tertiary EFL students' employment of oral communication strategies. *The International Journal of Interdisciplinary Social Sciences*, 5(10), 85-101. Retrieved from <http://www.SocialSciences-Journal.com>
- Sahiruddin. (2013, April). *The implementation of the 2013 Curriculum and the issues of English language teaching and learning in Indonesia*. Paper presented at the Asian Conference on Language Learning, Osaka, Japan.

- Sali, P. (2014). An analysis of the teachers' use of L1 in Turkish EFL classrooms. *System*, 42, 308-318. doi: 10.1016/j.system.2013.12.021
- Sasajima, S. & Ikeda, M. (2012). *Effective INSET programmes for CLIL teachers in an EFL context*. Paper presented 20th March, 2012 at the IATEFL Conference, Glasgow, UK. Retrieved from <http://iatefl.britishcouncil.org>
- Sato, R. (2010). Reconsidering the effectiveness and suitability of PPP and TBLT in the Japanese EFL classroom. *JALT journal*, 32(2), 189-200.
- Saukah, A. (2009). Language teacher education in Indonesia. In B. Spolsky (Ed.), *English language teacher education in Asia* (pp. 1-28). Seoul: ASIA TEFL.
- Schleppegrell, M., Achugar, M., & Oteíza, T. (2004). The Grammar of History: Enhancing Content-Based Instruction through a Functional Focus on Language. *TESOL Quarterly*, 38(1), 67-93. doi:10.2307/3588259
- Seidlhofer, B. (2005). English as a lingua franca. *ELT Journal*, 59, 339-41. doi: 10.1093/elt/cci064
- Sen, H., & Sen, M. (2012). A comparison of EFL teachers' perceptions of language learning strategies (LLSS) and learners' reported use of llss in their English language classes. *Procedia - Social and Behavioral Sciences*, 46, 1846-1854. Retrieved from <http://www.sciencedirect.com.dbgw.lis.curtin.edu.au>
- Shmais, W. A. (2003). Language learning strategy use in Palestine. *TESL-EJ*, 7(2). Retrieved from <http://www.tesl-ej.org/wordpress/issues/volume7/ej26/ej26a3/>
- Shor, I. (1987). *Critical teaching and everyday life*. Chicago: University of Chicago Press.
- Smith, B. (2003). The use of communication strategies in computer-mediated communication. *System*, 31, 29-53. Retrieved from <http://www.sciencedirect.com.dbgw.lis.curtin.edu.au>
- Snow, M. A. (1991). Content-based instruction: A method with many faces. In J. E. Alatis (Ed.), *Georgetown University Round Table on Languages and Linguistics (GURT) 1991: Linguistics and language pedagogy: The state of the art* (pp. 461-470). Washington, D.C.: Georgetown University Press.
- Sukyadi, D., & Mardiani, R. (2011). The washback effect of the English National Examination (ENE) on English teachers' classroom teaching and students' learning. *K@ ta*, 13(1), 96. doi: 10.9744/kata.13.1.96-111
- Sulistyo, G. H. (2015). English as a measurement standard in the national examination: Some grassroots' voice. *TEFLIN Journal-A publication on the teaching and learning of English*, 20(1), 1-24.

- Sung, C. C. M. (2014). English as a lingua franca and global identities: Perspective from four second language learners of English in Hong Kong. *Linguistics and Education*, 26, 31-39. Retrieved from <http://www.sciencedirect.com.dbgw.lis.curtin.edu.au>
- Suryanto, S. (2015). Issues in teaching English in a cultural context: A case of Indonesia. *Journal of English Literacy Education*, 1(2), 75-82. Retrieved from <http://ejournal.unsri.ac.id>
- Suryati, N. (2015). Classroom interaction strategies employed by English teachers at lower secondary schools. *TEFLIN Journal*, 26(2), 247. Doi: /10.15639/teflinjournal.v26i2/247-264
- Swain, M., Kinnear, P., & Steinman, L. (2011). *Sociocultural theory in second language education: An introduction through narratives*. Bristol: Multilingual Matters.
- Tarone, E. (1977). Conscious communication strategies in interlanguage: A progress report. In H. D. Brown, C. A. Yorio, & R. C. Crymes (Eds.), *On TESOL '77* (pp. 194–203). Washington, DC: TESOL.
- Tarone, E. (1981). Some thoughts on the notion of 'communication strategy'. *TESOL Quarterly*, 15, 285–295. Retrieved from <http://www.jstor.org>
- Tasnimi, M. (2014). The role of teacher in the postmethod era. *International Journal of Multi Disciplinary Research*, 1(3), 1-8. Retrieved from <http://s3.amazonaws.com/academia.edu.documents>
- Taylor, P. C., Taylor, E., & Luitel, B.C. (2012). Multi-paradigmatic transformative research as/for teacher education: An integral perspective. In K. G. Tobin, B. J. Fraser & C. McRobbie (Eds.), *Second international handbook of science education* (pp. 373-387). Dordrecht, The Netherlands: Springer.
- Temirova, F., & Westall, D. (2015). Analysis of First and Foreign Language Use in Content and Language Integrated Learning (CLIL) Classrooms. *Procedia - Social and Behavioral Sciences*, 178, 217-221.
- Todd, R. W. (2005). In an aeroplane, yes, in an aeroplane: Within-unit repetitions in classroom discourse. *RELC Journal*, 36(2), 189-209.
- Tutyandari, C. (2005, December). *Breaking the silence of the students in an English language class*. Paper presented at the 53rd TEFLIN International conference, Yogyakarta, Indonesia.
- Uemura, T. (2013). Implementing content and language integrated learning (CLIL) approach to TOEIC preparatory lessons. *Asian EFL Journal*, 15(4), 305-323. Retrieved from <http://asian-efl-journal.com>
- Fakultas Sastra dan Budaya: Pedoman Akademik*. (2011). Gorontalo: Universitas Negeri Gorontalo.

- Vardanjani, A. M. (2014). Applying language games in EFL classroom context. *Asian Journal of Research in Social Sciences and Humanities*, 4(3), 427-437.
- Vo, H. N. (2016). Towards building curricula for fostering autonomous vocabulary learning: A case of Vietnamese EFL context. *Turkish Online Journal of English Language Teaching (TOJELT)*, 1(3), 119-125
- Vygotsky, L. S. (1978). *Mind in society: The development of higher psychological process* (M. Cole, V. John-Steiner, S. Scribner & E. Souberman, Trans.). Cambridge, MA: Harvard University Press.
- Waring, R. (2008). Starting extensive listening. *Extensive Reading in Japan*, 1(1), 7-9.
- Wati, H. (2011). The effectiveness of Indonesian English teachers training programs in improving confidence and motivation. *International Journal of Instruction*, 4(1), 79-104. Retrieved from <http://files.eric.ed.gov/fulltext/ED522911.pdf>
- Wharton, G. (2000). Language learning strategy use of bilingual foreign language learners in Singapore. *Language Learning*, 50(2), 203-244. doi: 10.1111/0023-8333.00117
- Widiati, U., & Cahyono, B. Y. (2006). The teaching of EFL speaking in the Indonesian context: The state of the art. *Bahasa dan Seni*, 34(2), 269-292. Retrieved from <http://sastra.um.ac.id/wp-content/uploads/2009/10/>
- Wijaya, H. P. (2008). *The Impacts of changes in education policy on ELT in Indonesia*. Paper presented at the 28th Thailand TESOL. Khon Kaen, Thailand.
- Willems, G. M. (1987). Communication strategies and their significance in foreign language teaching. *System*, 15(3), 351-364. Retrieved from <http://www.sciencedirect.com.dbgw.lis.curtin.edu.au>
- Wu, C. J., Chen, G. D., & Huang, C. W. (2014). Using digital board games for genuine communication in EFL classrooms. *Educational Technology Research and Development*, 62(2), 209-226.
- Yamaguchi, C. (2002). Towards international English in EFL classrooms in Japan. *The Internet TESL Journal*, 8(1). Retrieved from <http://www.iteslj.org>
- Yang, W. (2015). Content and language integrated learning next in Asia: evidence of learners' achievement in CLIL education from a Taiwan tertiary degree programme. *International Journal of Bilingual Education and Bilingualism*, 18(4), 361-382. doi: 10.1080/13670050.2014.904840
- Yin, R. K. (1984). *Case study research: Designs and methods*. Beverly Hills: Sage Publications.

- Yulia, Y. (2013). Teaching challenges in Indonesia: Motivating students and teachers' classroom language. *Indonesian Journal of Applied Linguistics*, 3(1), 1-16. Retrieved from <http://ejournal.upi.edu>
- Zacharias, T. N. (2003). *A survey of tertiary teachers' beliefs about English Language Teaching in Indonesia with regard to the role of English as a global language* (Unpublished MA thesis). Thailand University, Thailand. Retrieved from <http://asian-efl-journal.com>
- Zacharias, N. T. (2014). Second language teacher contributions to student classroom participation: A narrative study of Indonesian learners. *English Language Teaching World Online*, 6, 1-15. Retrieved from <http://blog.nus.edu.sg>
- Zein, S. (2014). Pre-service education for primary school English teachers in Indonesia: policy implications. *Asia Pasific Journal of Education*, 36(1), 119 - 134. doi: 10.1080/02188791.2014.961899
- Zhang, W. S. (2007). Teach more strategies in EFL college listening classroom. *Online Submission*, 4(3), 71-76. Retrieved from <http://files.eric.ed.gov>

Every reasonable effort has been made to acknowledge the owners of copyright material. I would be pleased to hear from any copyright owner who has been omitted or incorrectly acknowledged.

Appendix 1

Information Sheet for the English Language Lecturers

I would like to thank you for agreeing to participate in this research. In this information sheet, you will find out what this research is about and what your participation in it will entail. The aim of this research is to investigate your views, as Indonesian English language lecturers, on oral communication strategies (OCS) instruction in the context of English Education Program at *Universitas Negeri Gorontalo* in Indonesia. OCS are those strategies that help language learners find ways to maintain involvement in a target language conversation and to enhance the quality of such involvement using skills such as paraphrasing, appealing for help, or gestures.

To elicit your views, I would like to conduct an interview with you. If you agree to this, the interview will be audio recorded and will last for 45-60 minutes. Prior to this interview, I would like to observe some of your classes as a non-participant observer in the classroom. The observation will be done 2-3 times and last for the entire classroom hours (100-150 minutes each time). Where necessary, I would also like to observe your classes for several times after the interview. In addition, I would like you to provide me with your syllabus and lesson plans that you are currently using (or have used previously). All the interviews will be done in Bahasa Indonesia. Yet, English may be used when requested.

Please be advised that all information that is collected during this research will be used for research purposes only, such as thesis, publications and conference presentations. Your name will be protected at all times by assigning you a pseudonym. Data from this research will be stored in secured locked storage at the School of Education at Curtin University, and will only be accessible by myself (the researcher) and my supervisors. Your participation in this research is voluntary which means that you can withdraw at any time without prejudice or negative consequences. The ultimate goal of this research to help improve the English Education Program in providing schools in Gorontalo, in particular, with qualified and effective English language teachers (and users).

This study has been approved under Curtin University's process for lower-risk Studies (Approval Number EDU-156-14). This process complies with the National Statement on Ethical Conduct in Human Research (Chapter 5.1.7 and Chapters 5.1.18-5.1.21). For further information on this study contact the researchers or the researcher's supervisors named below or the Curtin University Human Research Ethics Committee. c/- Office of Research and Development, Curtin University, GPO Box U1987, Perth 6845 or by telephoning 9266 9223 or by emailing hrec@curtin.edu.au.

Contact Details:

Researcher : Abid
Email : abid@student.curtin.edu.au

Main Supervisor : Dr. Paul Mercieca
Email : p.mercieca@exchange.curtin.edu.au

Information Sheet for the Pre-Service Teachers

I would like to thank you for agreeing to participate in this research. In this information sheet, you will find out what this study is about and what your participation in it will entail. The aim of this research is to investigate your views, as pre-service teachers, on oral communication strategies (OCS) instruction in the context of the English Education Program at *Universitas Negeri Gorontalo* in Indonesia. OCS are those strategies that help language learners find ways to maintain involvement in a target language conversation and to enhance the quality of such involvement using skills, such as paraphrasing, appealing for help, or gestures.

In order to achieve this aim, I would also like to have an interview with you. By so doing, I expect to arrive at a better understanding of how OCS instruction is viewed in the program by comparing the perspectives from two points of views, i.e. Indonesian English learners and English language lecturers. Therefore, I would like to interview you. If you agree to this, the interview will be audio recorded and will last for approximately 45-60 minutes. You may choose to have an interview in Bahasa Indonesia or English.

Please be advised that all information that is collected during this research will be used for research purposes only, such as thesis, publications and conference presentations. Your identity will be kept anonymous using only pseudonyms. Data from this research will be stored in secured locked storage at the School of Education at Curtin University, and only accessible by myself (the researcher) and my supervisors.

Your participation in this research is voluntary which means that you are free to withdraw at any time without prejudice or negative consequences. The ultimate goal of this research is to help improve the English Education Program in providing schools in Gorontalo, in particular, with qualified and effective English language teachers (and users).

This study has been approved under Curtin University's process for lower-risk Studies (Approval Number EDU-156-14). This process complies with the National Statement on Ethical Conduct in Human Research (Chapter 5.1.7 and Chapters 5.1.18-5.1.21). For further information on this study contact the researchers or the researcher's supervisors named below or the Curtin University Human Research Ethics Committee. c/- Office of Research and Development, Curtin University, GPO Box U1987, Perth 6845 or by telephoning 9266 9223 or by emailing hrec@curtin.edu.au.

Once again, I would like to thank you for agreeing to take part in this research.

Contact Details:

Researcher	: Abid
Email	: abid@student.curtin.edu.au
Main Supervisor	: Dr. Paul Mercieca
Email	: p.mercieca@curtin.edu.au

Appendix 2

Interview Protocols For the English language lecturers

A. Establishing a good rapport with the interviewee

- a) Ask the interviewee's ID number.
- b) Explain the outline of the interview.
- c) Elicit information on the interviewee's background
- d) Ask the interviewee general question about difficulties in English conversation.

Eliciting background information

1. Sudah berapa lama anda mengajar? [How long have you been teaching?]
2. Apa kualifikasi akademik anda? [What are your academic qualifications?]
3. Apa jabatan lain yang anda emban di jurusan/fakultas/universitas ini? [What other roles do you play at this department/faculty/university?]
4. Matakuliah apa yang sudah pernah anda ajarkan (dan apa yang sedang anda ajarkan saat ini)? [What units have you taught (and are you teaching now)?]
5. Bagaimana anda menggambarkan tingkat penguasaan Bahasa Inggris anda? [How would you describe your level of English proficiency?]

List of questions:

6. Apa yang anda harapkan dari mahasiswa setelah mereka menyelesaikan matakuliah Speaking/Listening? [What do you expect students to be able to do upon the completion of Speaking/Listening unit?]
7. Apakah anda menggunakan buku teks dalam matakuliah Speaking/Listening? Bagaimana anda menggunakannya? [To what extent do you rely on course books in teaching Speaking/Listening?]
8. Menurut anda, apa masalah yang sering dihadapi pelajar bahasa ketika berinteraksi dalam Bahasa Inggris baik di dalam maupun di luar kelas? [In your opinion, what problem(s) do language learners experience in English conversations inside and outside the classroom?]
9. Menurut anda, apa penyebab munculnya masalah tersebut? [In your opinion, what causes the problem(s)?]
10. Menurut anda, bagaimana cara mengatasi masalah tersebut? [In your opinion, how can the problem(s) be solved?]

B. Eliciting core information

- a) Tell the interviewee about the shift of focus on to oral communication strategies in speaking.
- b) Ask questions about oral communication strategies.

List of questions:

11. Menurut anda, kegiatan apakah yang dapat meningkatkan kecakapan berbicara di dalam kelas? [In your opinion, what kind of classroom activities that promotes fluency?]
12. Strategi apa yang anda gunakan ketika anda menemui kendala berkomunikasi ketika berbicara dalam Bahasa Inggris, baik di dalam maupun di luar kelas? [What strategies do you use when you encounter communication problems while speaking English inside and outside the classroom?]
13. Menurut anda, apa alasan menggunakan strategi tersebut? [In your opinion, what are the reasons for using the strategy(ies)?]
14. Menurut anda, apa fungsi penggunaan bahasa Inggris yang sesuai dengan kepentingan mahasiswa anda? [In your opinion, which functions does English serve that are relevant for the learners?]
15. Menurut anda, strategi apa yang dibutuhkan oleh mahasiswa anda untuk berkomunikasi lisan? [In your opinion, what kind of strategies do students need to use to communicate?]
16. Menurut anda, apa implikasi pedagogis dari penggunaan strategi tersebut di dalam kelas bahasa Inggris? [In your opinion, what are the pedagogical implications of using the strategies in English language classrooms?]
17. Mengapa anda mengajarkan/tidak mengajarkan strategi-strategi tersebut? [Why do/do not you teach the strategy(ies)?]
18. Jika anda mengajarkan strategi-strategi tersebut, bagaimana anda mengajarkannya? [If you teach the strategy(ies), how do you teach them?]

C. Thanking the interviewee

First, thank the interviewee for his/her time. Second, ask the interviewee to contact the researcher if s/he has extra information about the teaching or the use of oral communication strategies in the context of English Education Program. Third, record the interviewee's contact number/email address.

An Interview Protocols for the Pre-Service Teachers

A. Establishing a good rapport with the interviewee

- a) Ask the PST ID number.
- b) Explain the outline of the interview.
- c) Elicit information on the interviewee's background
- d) Ask the interviewee general question about difficulties in English conversation.

Eliciting background information

1. Sudah berapa lama anda belajar Bahasa Inggris? [How long have you been studying English?]
2. Bagaimana anda belajar bahasa Inggris selama ini? [How have you learnt English?]
3. Kapan anda memulai kuliah di Jurusan Pendidikan Bahasa Inggris? [When did you start doing your undergraduate degree at the Department of English Education?]
4. Anda berada di semester berapa saat ini? [In what semester are you now?]
5. Pengalaman profesional apa yang berkaitan dengan penggunaan Bahasa Inggris yang pernah anda jalani? [What professional experiences associated with English use have you had?]

List of questions:

6. Apa yang anda harapkan setelah anda menyelesaikan matakuliah Speaking/Listening? [What do you expect to be able to do upon the completion of Speaking/Listening unit?]
7. Apakah anda menggunakan buku teks dalam matakuliah Speaking/Listening? Bagaimana anda menggunakannya? [To what extent do you rely on course books in teaching Speaking/Listening?]
8. Menurut anda, apa masalah yang sering anda temui ketika berbicara dalam Bahasa Inggris baik di dalam maupun di luar kelas? [In your opinion, what problem(s) do you often experience in English conversations inside and outside the classroom?]
9. Menurut anda, apa penyebab munculnya masalah tersebut? [In your opinion, what causes the problem(s)?]
10. Menurut anda, bagaimana cara mengatasi masalah tersebut? [In your opinion, how can the problem(s) be solved?]

B. Eliciting core information

- a) Tell the interviewee about the shift of focus on to oral communication strategies in speaking.
- b) Ask questions about oral communication strategies.

List of questions:

11. Menurut anda, kegiatan apakah yang dapat meningkatkan kecakapan berbicara di dalam kelas? [In your opinion, what kind of classroom activities that promotes fluency?]
12. Menurut anda, apa fungsi penggunaan bahasa Inggris yang sesuai dengan kepentingan anda? [In your opinion, which functions does English serve that are relevant for you?]
13. Bagaimana anda mengatasi kesulitan saat berbicara dalam Bahasa Inggris baik di dalam maupun di luar kelas? [How do you cope with communication difficulties while speaking English both inside and outside the classroom?]
14. Menurut anda, apa alasan menggunakan strategi tersebut? [In your opinion, what are the reasons for using the strategy(ies)?]
15. Bagaimana anda mengetahui strategi tersebut? [How did you learn the strategy(ies)?]
16. Menurut anda, seberapa bermanfaat strategi tersebut dalam komunikasi menggunakan Bahasa Inggris? [In your opinion, how useful are these strategy(ies) in English oral communication?]

17. Menurut anda, apa implikasi pedagogis dari penggunaan strategi tersebut di dalam kelas bahasa Inggris? [In your opinion, what are the pedagogical implications of using the strategies in English language classrooms?]

C. Thanking the interviewee

First, thank the interviewee for his/her time. Second, ask the interviewee to contact the researcher if s/he has extra information about the use or the benefits of learning oral communication strategies in the context of English Education programs. Third, record the interviewee's contact number/email address.

Appendix 3

Observation Field-note Template

Oral communication strategies instruction: Voices from Indonesian English language lecturers

Classroom Observational Field Note Template

Unit Name :
Unit Coordinator :
Role of Observer : *Non-participant observer*

Time & Date :
Length of Observation : *minutes*

<i>Time</i>	<i>Description of teacher activities</i>	<i>Description of students activities</i>	<i>Reflective Notes</i>
<i>1st 20 minutes</i>			
<i>2nd 50 minutes</i>			
<i>3rd 30 minutes</i>			