

PAPER • OPEN ACCESS

Modelling batch microwave heating of water

To cite this article: S P Yeong *et al* 2017 *IOP Conf. Ser.: Mater. Sci. Eng.* **217** 012035

View the [article online](#) for updates and enhancements.

Related content

- [Modeling of Lithium Niobate \(LiNbO₃\) and Aluminum Nitride \(AlN\) Nanowires Using Comsol Multiphysics Software: The Case of Pressure Sensor](#)
A.A. Ahmad, A. Alsaad, Q.M. Al-Bataineh et al.
- [Microwave holographic interferometry](#)
V M Ginsburg, V M Meschankin, G I Ruhkman et al.
- [A Modified Branch and Bound Algorithm for Batch Scheduling in Discrete Manufacture System](#)
A S Indrapriyatna and H Triha



IOP | ebooks™

Bringing you innovative digital publishing with leading voices to create your essential collection of books in STEM research.

Start exploring the collection - download the first chapter of every title for free.

Modelling batch microwave heating of water

S P Yeong¹, M C Law¹ C C Vincent Lee¹ and Y S Chan²

¹ Mechanical Engineering Department, Curtin University Malaysia, CDT 250, 98009 Miri, Sarawak, Malaysia.

² Chemical Engineering Department, Curtin University Malaysia, CDT 250, 98009 Miri, Sarawak, Malaysia.

E-mail: yeong.siew.ping@postgrad.curtin.edu.my

Abstract. A numerical model of the microwave heating of distilled water is developed using COMSOL Multiphysics software to investigate the microwave effects on the heating rate. Three frequencies (0.915GHz, 2GHz and 2.45 GHz) have been applied in the model in order to study their influences on the water temperature. It is found that the water heats up at 2GHz and 2.45GHz, however, there is no sign of heating at 915MHz. This is supported with the figures of the electric field distribution in the microwave cavity. The results shown in the developed model is validated with the experimental results obtained at 2.45 GHz.

1. Introduction

Microwave is an alternative heat source which has attracted higher demands in industrial and household applications over the years. In contrast to conventional heating where heat is transferred from the surface to the inner volume of the object, microwave penetrates into materials and quickly converted into thermal energy within the volume. This instantaneous volumetric heating can heat up an object much faster and reduce the process time required.

However, one major disadvantage which prohibits the advancement in microwave technology is the uneven heating distribution within a material due to non-uniform electric field patterns. In order to reduce the uneven heating pattern, rotating glass turntable plate are used in the domestic microwave ovens to rotate the foods during heating. However, this method might not be suitable for industrial applications where the equipment are not designed to rotate. Hence, there is a need to investigate the natural heat convection in the sample to better understand the microwave dielectric heating phenomena.

As compared to microwave heating solid specimen, liquid samples are considerably more challenging to perform analysis due to the presence of fluid motion. This would lead to the complex interactions of flow fields, microwave fields, and local distributions of temperature within the liquid.

The numerical models developed are mostly solving Maxwell's equations, heat transfer and fluid flow equations [1-3]. Some uses Lambert's Law [4] to solve the electromagnetic field when the samples are thicker and have a larger depth than the penetration depth of microwaves, causing the microwave intensity to reduce exponentially with the depth. For samples with smaller, electromagnetic field inside the sample are usually solved using Maxwell's equation as the heat transfer rate is faster.

Zhang et al. have developed a three dimensional model to predict the distribution of electromagnetic fields, temperatures, and velocities of liquids enclosed in a container which is located within a microwave cavity. They have reported that convection plays an important role on the



temperature distribution within the liquid [5]. Thus, fluid flow during a heating process should be investigated. On the other hand, Sabliov et al. numerically investigated the heating of a continuous flow liquid in a microwave system using ANSYS Multiphysics [6]. It was assumed that the dielectric properties of the liquid are temperature independent as their goal is to predict the effect of flow rate on the temperature distribution at 915MHz. The dielectric properties of the water they used (a constant value) is calculated from the empirical formula determined by Komarov and Tang [7] for tap water.

Ratanadecho et al. have investigated the microwave heating of a liquid layer both numerically and experimentally. Their work showed that the electric conductivity value of a liquid could strongly affect the degree of microwave penetration and heating rate within the liquid layer [1]. This conductivity rises as the concentration of ions present in the liquid increases. Cha-um et al. have numerically and experimentally studied the microwave heating of water and oil which possess different dielectric properties, using a rectangular waveguide. The temperature profiles and velocity field within sample are determined to examine the effects of microwave power level, position of the waveguide, and liquid layer size and thickness on the liquid heating [2]. Nonetheless, a research conducted by Rattanadecho [8] on wood reveals that microwave frequency could also affect the temperature distribution within a sample.

Although most of the previous investigations considered simulations of microwave heating in liquid, a little effort has been reported on performing investigation on the influence of frequencies in heating liquid. This work serves as a preliminary study on the microwave heating of liquids and focus on predicting the effect of microwave frequencies on the heating rate as well as the flow field through a numerical model. Distilled water is selected as the test fluid.

2. Model Description

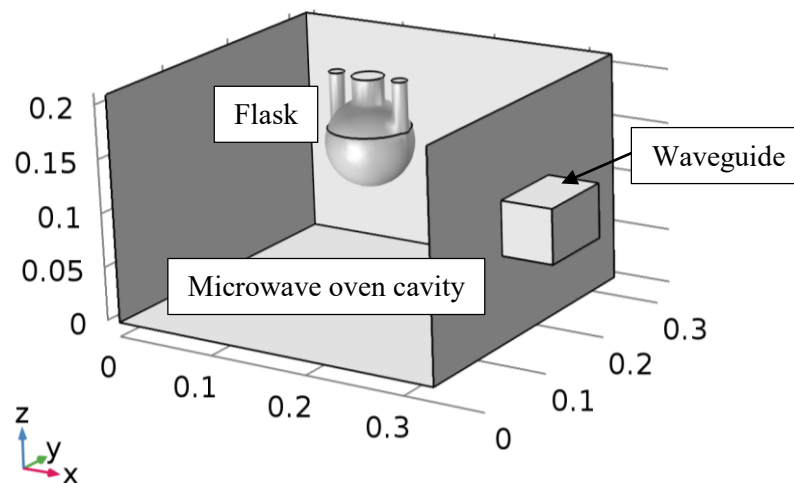

Figure 1 COMSOL model

A model as depicted in Figure 1 is developed. It consists of a waveguide, microwave resonant cavity and a three-neck flask which is filled with water. The dimension of the microwave oven and flask are listed in Table 1.

Table 1 Geometrical parameters of the COMSOL model

Parameters	Value
Oven cavity dimension (mm)	330 (w) × 309 (d) × 211 (h)
Waveguide (m)	0.05 (w) × 0.08 (d) × 0.05 (h)
Flask diameter (m)	0.08
Initial temperature, T_0 (K)	298.15
Flask height from the bottom of oven, h_f (m)	0.151

In this simulation, the relative permittivity of distilled water is assumed to vary with frequency but temperature independent. The values used are listed in Table 2 as follows:

Table 2 Relative permittivity of distilled water at room temperature (25°C)

Frequency, f (GHz)	ϵ'	ϵ''	Reference
0.915	78.9	3.60	[9]
2.00	77.9	7.57	[10]
2.45	78.0	12.50	[11]

Some assumptions that are applied in this model are as follows [2]:

1. The absorption of microwave by the air in a microwave cavity is negligible
2. The walls of the microwave oven are perfect electric conductors
3. The flask is a heat insulator and has no effect on the electromagnetic and temperature field
4. Fluid is incompressible
5. Gravity effect is considered

The numerical modelling of the microwave heating of water is carried out using COMSOL Multiphysics v5.2a software. The physic models that have been coupled in the COMSOL model are electromagnetic waves (frequency domain) under radio frequency module, heat transfer in fluids under heat transfer module, and laminar flow under fluid flow module. Radio frequency module is employed to solve Maxwell's equations, while heat transfer and fluid flow modules are used to solve Fourier and Navier Stokes equations. The radio frequency module is coupled with the fluid flow and heat transfer modules in such a way that the heat generation terms calculated using radio frequency module are then used to calculate the temperature field. Simulations are run on Intel Xeon CPU E5-2695 @ 2.3 GHz processor with 256GB RAM.

3. Governing Equations

Electromagnetic waves physic model is applied in the entire domain of the microwave oven whereas the latter two models are limited to the liquid region enclosed by the flask. The details related to each physic model are further described in the following subsections.

3.1. Electromagnetic waves, frequency domain

A rectangular port with Transverse electric (TE₁₀) mode is employed in this physics model to represent the microwave generator (magnetron). The port power is set at 300W. The modelling of microwave heating is governed by Maxwell's equation as follows:

$$\nabla \times \left(\frac{1}{\mu'} \nabla \times \vec{\mathbf{E}} \right) - \frac{\omega^2}{c^2} (\epsilon' - j\epsilon'') \vec{\mathbf{E}} = 0 \quad (1)$$

where μ' is the relative permeability, \vec{E} is the electric field intensity inside the microwave cavity (V/m), ω is the angular frequency (rad/s), c is the speed of light in free space (3×10^8 m/s), ϵ' is the relative permittivity or dielectric constant, and ϵ'' is the relative dielectric loss of a material. Dielectric constant measures the ability of a material to store electrical energy whereas dielectric loss indicates the ability of a material to loss the electrical energy as heat energy. After obtaining the electric field intensity from Equation 1 and the material properties, the volumetric power P_V dissipated from the electric component of microwaves can be determined as follows (Salvi et al., 2011):

$$P_V = \sigma |\vec{E}|^2 = 2\pi\epsilon_0\epsilon'' f |\vec{E}|^2 \quad (2)$$

where σ is the electrical conductivity (S/m) and ϵ_0 represents the free space permittivity (8.854×10^{-12} F/m).

Walls of the microwave cavity are assumed to be made of copper which approximates perfect electrical conductors. This indicates that the microwave generated from the magnetron could not penetrate through these boundaries and it will only exist inside the microwave cavity to heat up liquid molecules. On the other hand, the three opening ends of the three-neck flask are also defined as impedance boundaries, but with the properties of air.

3.2. Heat transfer in fluids

The heat transfer in the liquid domain is governed by Fourier energy equation as follows:

$$\rho c_p \frac{\partial T}{\partial t} + \rho c_p \mathbf{u} \cdot \nabla T = \nabla \cdot (k \nabla T) + P_V \quad (3)$$

where ρ is the density (kg/m^3), T is the temperature (K), c_p is the specific heat capacity ($\text{J}/(\text{kg}\cdot\text{K})$), k is the thermal conductivity ($\text{W}/(\text{m}\cdot\text{K})$), and P_V is the thermal power received from the electromagnetic wave (W). It is assumed that phase change does not take place.

Since the electromagnetic waves physics model is in frequency domain, the electric field generated in the COMSOL model would not change in a time dependent study. To compensate that, the multiphysics coupling between the electromagnetic waves and heat transfer in fluids models will be disabled and replaced with a user-defined heat source. The heat source term, retrieved from the electromagnetic waves model, is multiplied with a piecewise function to imitate the ON/OFF cycle in a microwave oven (model: Samsung ME711K), which is approximately 13s ON and 18s OFF per cycle. In addition, the flask which is made from glass is assumed to be a heat insulator. Hence, there is no heat flux from the liquid domain to the ambient air inside the cavity which remains at 20°C . The liquid domain is illustrated in Figure 2.

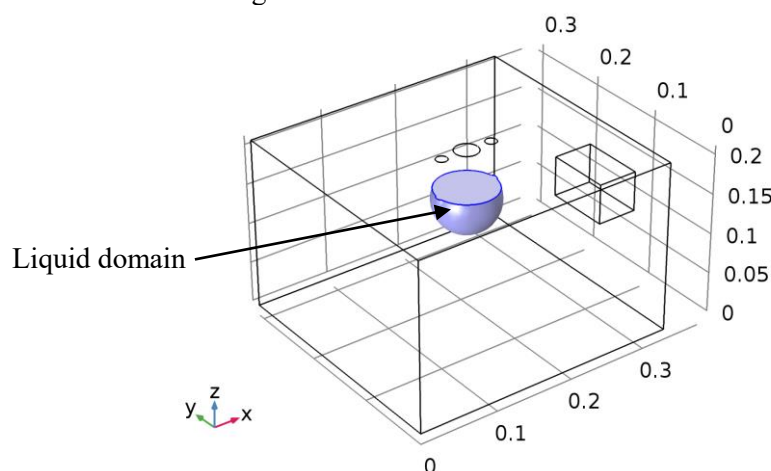

Figure 2 Liquid domain in COMSOL model

3.3. Laminar flow

The flow field of the liquid can be described by using single phase Navier-Stokes equations:

$$\frac{\partial \rho}{\partial t} + \nabla \cdot (\rho \mathbf{u}) = 0 \quad (4)$$

$$\rho \frac{\partial \mathbf{u}}{\partial t} + \rho \mathbf{u} \cdot \nabla \mathbf{u} = -\nabla p + \left[\mu (\nabla \mathbf{u} + (\nabla \mathbf{u})^T) - \frac{2}{3} (\mu (\nabla \cdot \mathbf{u})) \right] - \rho \mathbf{g} \quad (5)$$

where μ is dynamic viscosity (Pa.s), $(\nabla \mathbf{u})^T$ is transpose of $\nabla \mathbf{u}$ and \mathbf{g} is gravitational force (kg.m/s²).

A pressure outlet with suppressed backflow is applied at the liquid-air interface. This allows the pressure build up in the liquid during heating to be released through the interface.

4. Model Validation

4.1. Mesh Independence Analysis

The type of elements used in this model is free tetrahedral. The mesh size in fluid domain is set to be smaller compare to the remaining domain as it is the domain of interest. In order to examine the effect of mesh size refinement on the model solution, the temperature difference of using different mesh size is studied as shown in Figure 3.

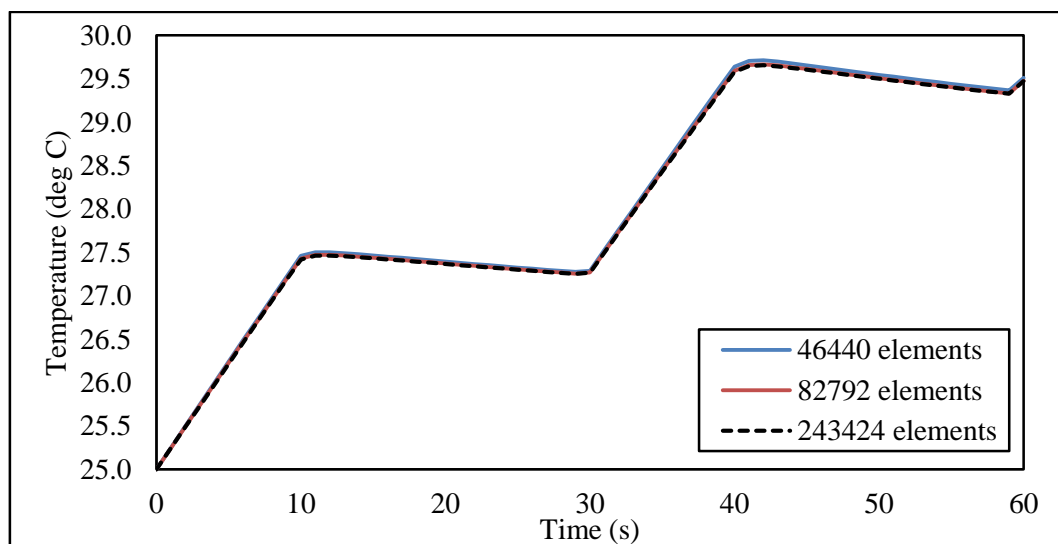

Figure 3 Effect of mesh size refinement on temperature change

As the mesh size refined, it is observed that the temperature change is insignificant. This shows that the mesh size do not need to be further refined and using 46440 elements is sufficient to obtain satisfying results. The simulation time required is approximately 12 minutes for each run.

4.2. Experimental Validation

In order to validate the model, an experiment has been conducted to measure the temperature rise of distilled water at 2.45GHz in a domestic microwave oven. The microwave power level is fixed at 300W. The temperature reading of the water is taken at a point inside the flask as shown in Figure 4 using the fibre optic thermometer for 2 minutes. The temperature measured in simulation model would be taken at this point as well.

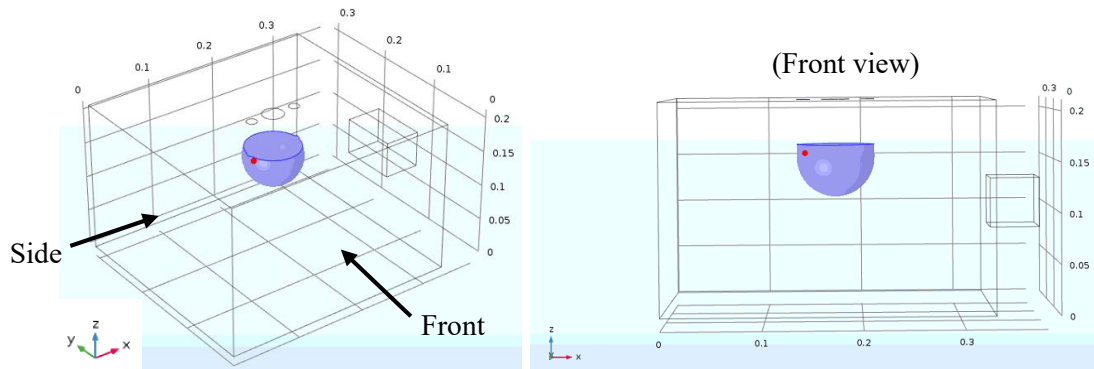

Figure 4 Temperature measuring point

Nine sets of readings has been taken in the experiment to plot the average temperature profile. The comparison between the simulated and experimental results is plotted in Figure 5.

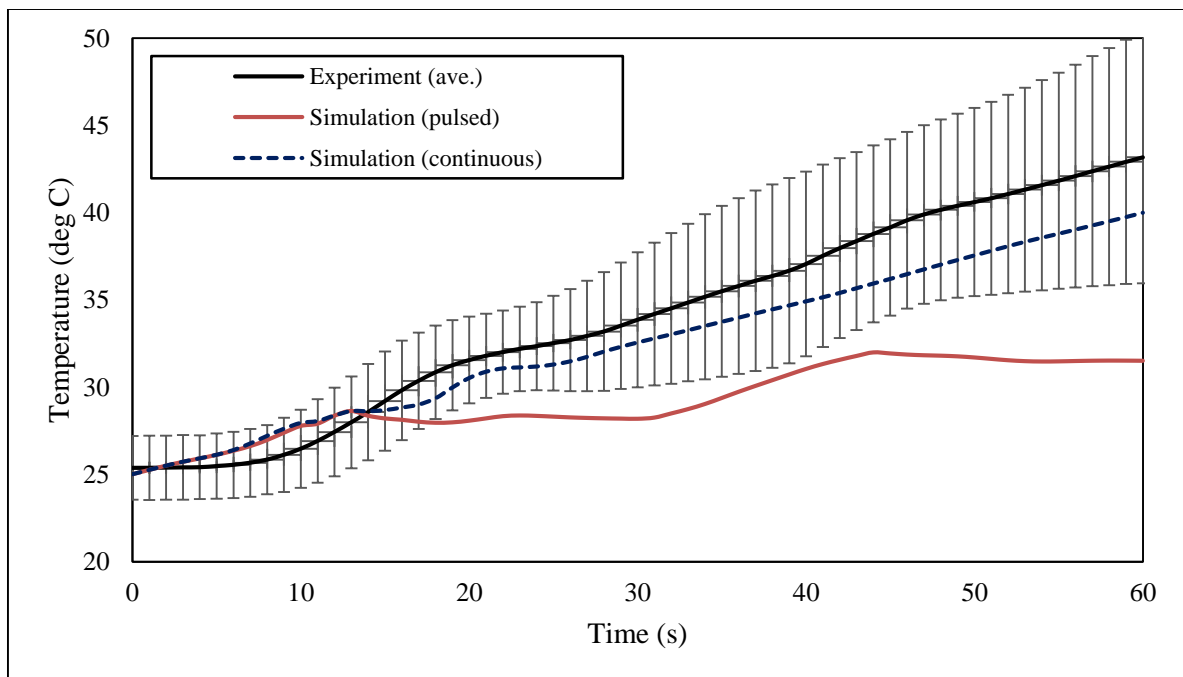

Figure 5 Temperature Profiles of distilled water at 2.45GHz microwave irradiation

As shown by the error bars of the experimental results, the standard deviation of temperature increases as time increases. It is found that the average temperature rise is roughly 17.8°C after heating for 60 seconds. However, the predicted temperature rise of distilled water using the simulation model is only around 6.5°C after a minute. The percentage error increases from 0.4% to 37% as time passes. Nonetheless, the prediction is within the deviation range of the experimental average temperature profile for the first 18 seconds. After that, the simulation result falls out of the range for the remaining time, although it is still slowly increasing.

The possible sources of error include the purity of the distilled water and the waveguide dimension. The electrical conductivity of the distilled water was not tested due to equipment unavailability. This is of concern as the presence of ions would affect both the dielectric constant and dielectric loss of water. These ions will be excited by the microwave and creates additional heat energy which consequently increases the temperature.

During the model development, the dimension of the waveguide is actually a rough estimation based on the actual microwave oven. The equipment was not disassembled to obtain the exact measurement of the waveguide. This could have partially contribute to the discrepancies in simulation results.

Besides, after averaging nine sets of temperature profile, the effect of microwave ON and OFF cycle on the temperature change of experimental results has been dampen. The temperature continues to rise between 18th seconds and 31st seconds although theoretically there is no heat generation. However, more work need to be done here to prove that during the OFF cycle, there is no extra heat generated in the microwave oven. This could be done by using thermal imaging infrared camera to capture the temperature differences of the liquid during the heating process. If it is proved that the heat is continuously generated during the heating process in the experiment, then this model is able to predict the temperature difference as well under continuous heating condition as shown in Figure 5. The predicted temperature results would be slightly below the experimental results but still within the deviation range.

Nonetheless, the author strongly believes that there is no heat generated during the OFF cycle of microwave unless there is further confirmation on the experimental results using the thermal imaging technique. Hence, the pulsed setting will still be used in present work to investigate the effect of frequencies on microwave heating although the error might attain as high as 37%.

5. Effect of Frequencies

The temperature change of the water at three different frequencies is shown in Figure 6. It is found that the temperature increases as time goes by. After 13 seconds, the temperature will drop for 18 seconds as the pulsed microwave is turned off temporarily. As the microwave turns on again, the temperature will then continue to increase. Surprisingly, there is no significant temperature rise in the case of 915 MHz even after 60s. The water does not seem to be heated up after a minute of microwave irradiation. For the 2 GHz frequency, the temperature profile is almost identical to that of 2.45GHz. The slight temperature difference between the two frequencies is suspected to be caused by the convective flow happens within the water.

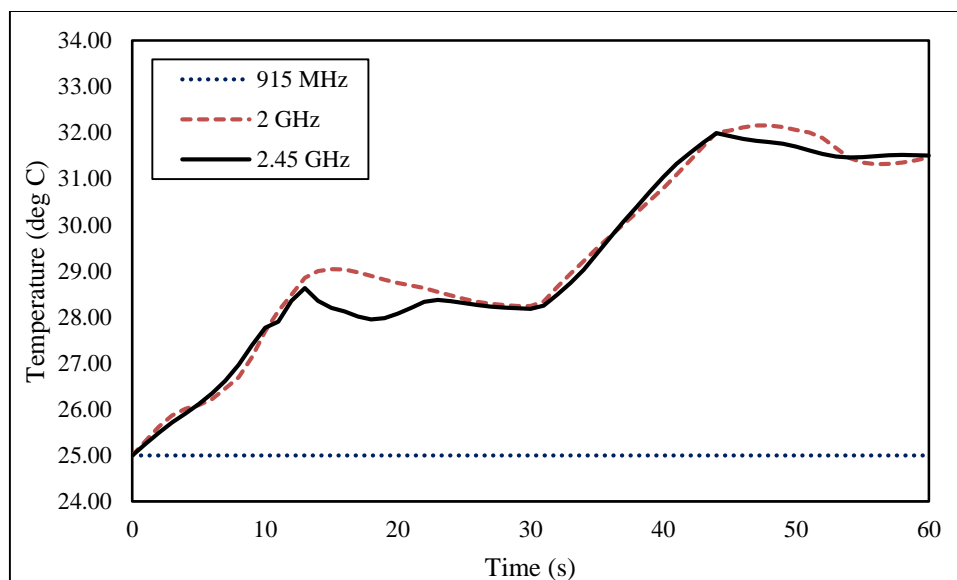

Figure 6 Temperature of distilled water at several frequencies

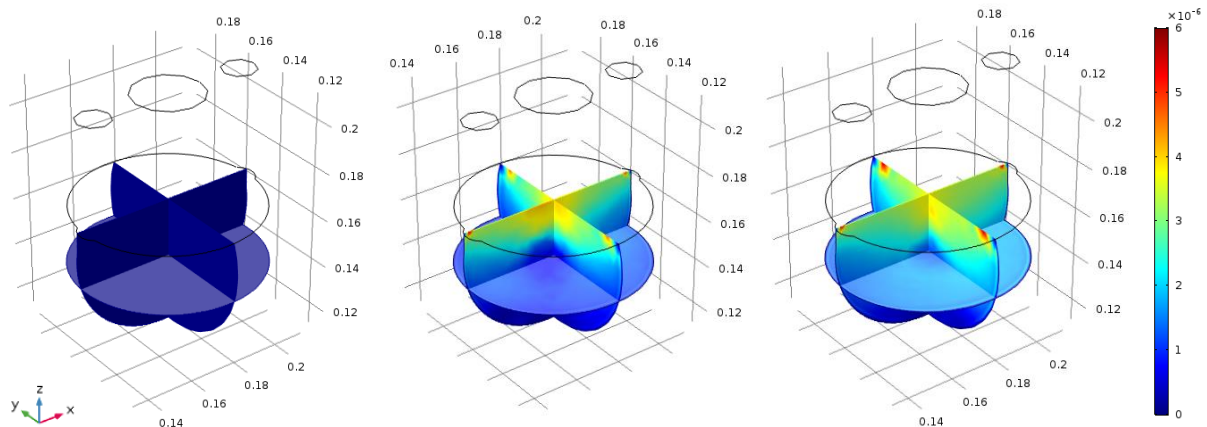

Figure 7 Fluid flow velocity (m/s) in distilled water at $t=60s$
(left: 0.915GHz, middle: 2GHz, right: 2.45 GHz)

As microwave is switched on, a fraction of the water absorbs the electromagnetic energy and heats up. This results in temperature variance within the water which promotes convection. As illustrated in Figure 7, the fluid flow mostly occurs near the water surface, except for the case of 0.915GHz, where there is no change in the velocity. The maximum velocity observed at 2 GHz and 2.45GHz is around 6×10^{-6} m/s, occurs at the water surface near the flask wall, which can be imagined to be in a ring shape, as indicated by the four red dots on the two planes. The velocity in 2.4GHz is slightly faster compared to 2GHz, and the heat distributes faster to the bottom section of the flask. This might have caused the sudden drop in temperature after 13th seconds and 44th seconds (as shown in Figure 6) for 2.45GHz as cooler water flows upwards from the bottom faster and absorbs heat.

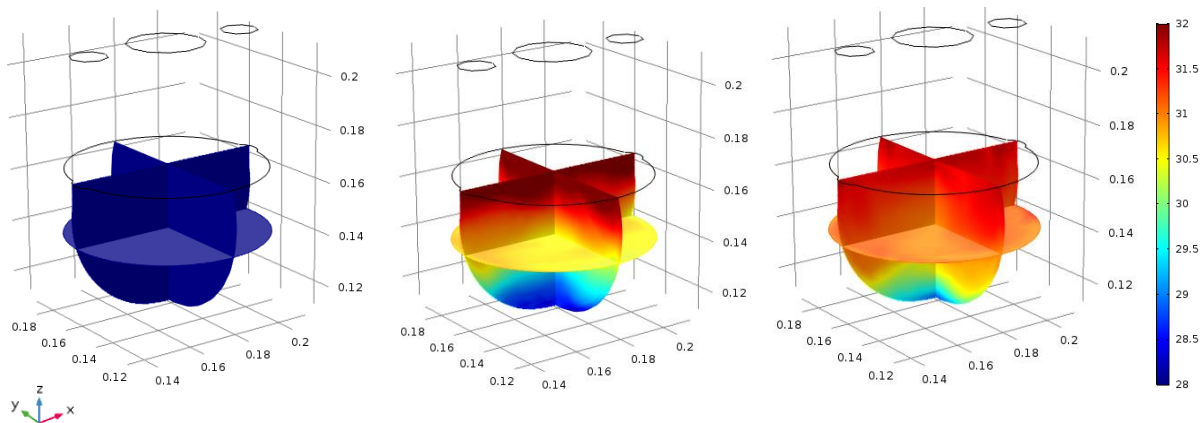

Figure 8 Temperature distribution ($^{\circ}C$) in distilled water at $t=60s$
(left: 0.915GHz, middle: 2GHz, right: 2.45GHz)

Figure 8 is plotted to better visualize the temperature variance of the water after 60 seconds. There is no change in temperature for 0.915GHz, as indicated in Figure 6. For 2GHz, the water temperature is obviously higher near the water surface while the temperature distribution for 2.45GHz is more thorough to the entire volume. Since the heat absorbed by the water is mainly from the electric field (microwave) generated, the electric fields at the three frequencies are plotted in Figure 9.

The electric field in the microwave cavity is very weak for 0.915 GHz. The highest electric field is only 4000 V/m which is found at the waveguide. As a result, the water has not absorbed enough amount of energy to raise its temperature.

For 2GHz, the electric field has become stronger and reaches 1.5×10^4 V/m, nearly fourfold of 0.915GHz. This is the same for 2.45 GHz as well. However, it is observed that the electric field is stronger in 2 GHz compared to 2.45GHz. The strong electric field as indicated by the red region occurs near the flask at 2GHz as shown from the front and side view in Figure 9. This explains the high temperature observed near the water surface for 2 GHz as depicted in Figure 8. Electric field around 6000 V/m could also be observed at the center of the liquid domain.

For 2.45 GHz, the strong electric fields locate about the water surface near the flask wall and at the bottom section of the flask. The total area of strong electric field for 2.45GHz are relatively smaller than 2 GHz when viewing from all three planes. This indicates that the water receives less electromagnetic energy at 2.45 GHz frequency.

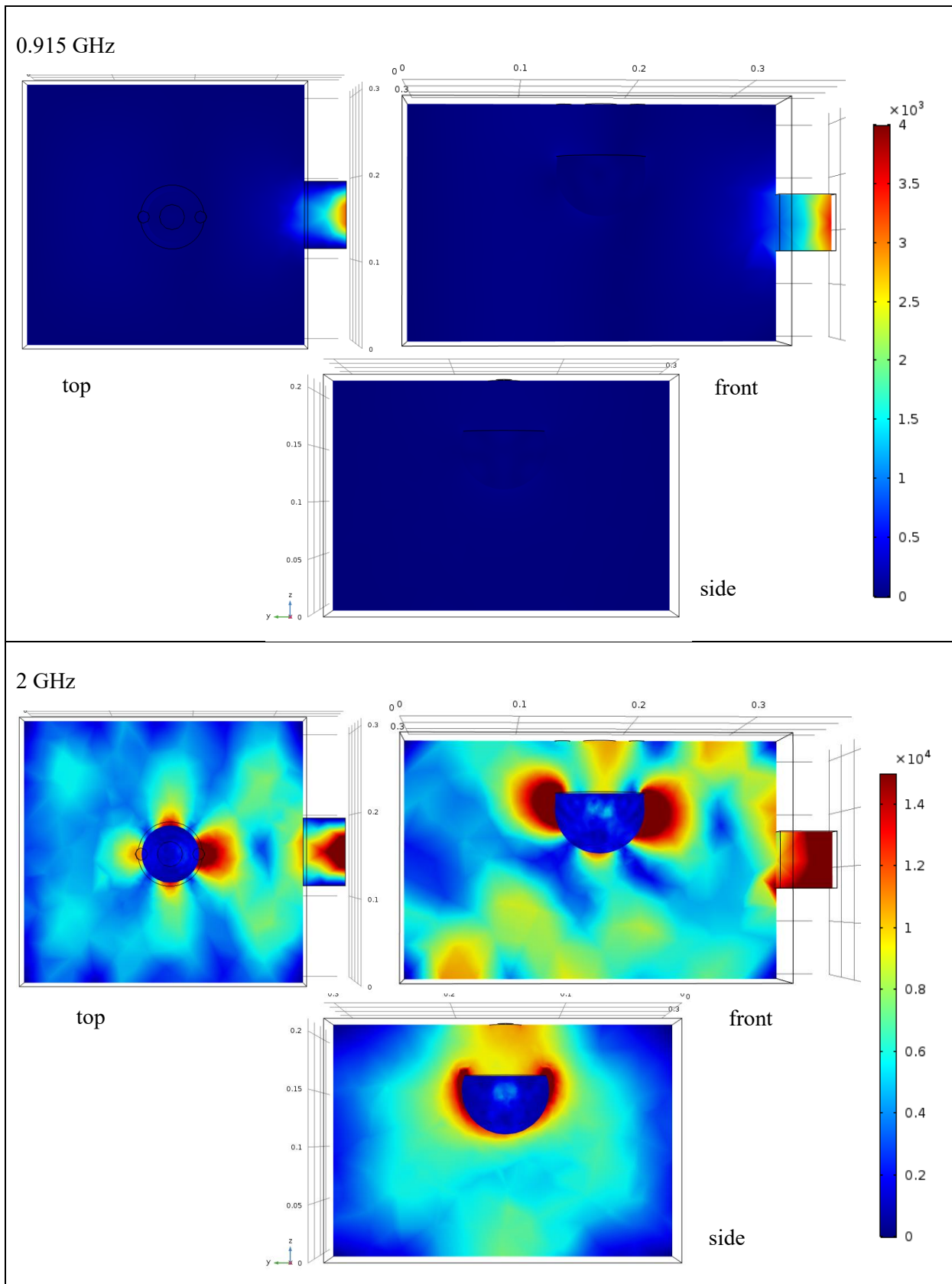

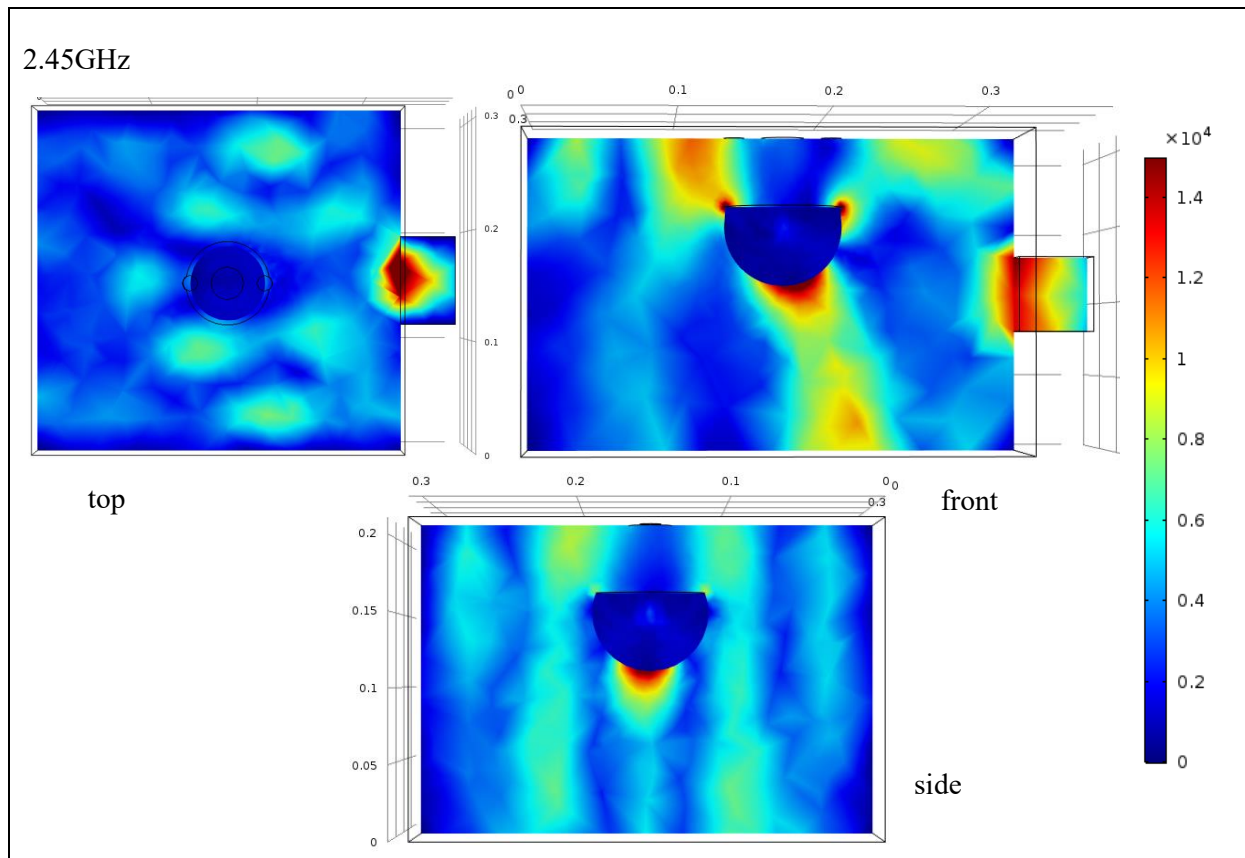

Figure 9 Electric field distribution (V/m) (top: 0.915GHz, middle: 2GHz, bottom: 2.45GHz)

6. Conclusion

A simulation model of the batch microwave heating of water is developed using COMSOL Multiphysics software. It is observed that the water is heated up at similar rate at 2 GHz and 2.45 GHz but the heating rate at 2GHz outperforms 2.45GHz. However, the water does not heat up at 915MHz due to weak electric field distribution in the microwave cavity. More experimental work should be carried out to validate the simulation model.

References

- [1] Ratanadecho, P., K. Aoki, and M. Akahori, *A numerical and experimental investigation of the modeling of microwave heating for liquid layers using a rectangular wave guide (effects of natural convection and dielectric properties)*. Applied Mathematical Modelling, 2002. **26**(3): p. 449-472.
- [2] Cha-um, W., P. Rattanadecho, and W. Pakdee, *Experimental and Numerical Analysis of Microwave Heating of Water and Oil Using a Rectangular Wave Guide: Influence of Sample Sizes, Positions, and Microwave Power*. Food and Bioprocess Technology, 2011. **4**(4): p. 544-558.
- [3] Yousefi, T., et al., *An investigation on the microwave heating of flowing water: A numerical study*. International Journal of Thermal Sciences, 2013. **71**: p. 118-127.

- [4] Datta, A., H. Prosetya, and W. Hu, *Mathematical Modeling of Batch Heating of Liquids in a Microwave Cavity*. Journal of Microwave Power and Electromagnetic Energy, 1992. **27**(1): p. 38-48.
- [5] Zhang, Q., T.H. Jackson, and A. Urgan, *Numerical modeling of microwave induced natural convection*. International Journal of Heat and Mass Transfer, 2000. **43**(12): p. 2141-2154.
- [6] M. Sabliov, C., D.A. Salvi, and D. Boldor, *High Frequency Electromagnetism, Heat Transfer and Fluid Flow Coupling in ANSYS Multiphysics*. Journal of Microwave Power and Electromagnetic Energy, 2006. **41**(4): p. 5-17.
- [7] Komarov, V.V. and J. Tang, *Dielectric permittivity and loss factor of tap water at 915 MHz*. Microwave and Optical Technology Letters, 2004. **42**(5): p. 419-420.
- [8] Rattanadecho, P., *The simulation of microwave heating of wood using a rectangular wave guide: Influence of frequency and sample size*. Chemical Engineering Science, 2006. **61**(14): p. 4798-4811.
- [9] Ikediala, J.N., et al., *Development of a saline water immersion technique with RF energy as a postharvest treatment against codling moth in cherries*. Postharvest Biology and Technology, 2002. **24**(2): p. 209-221.
- [10] Zahn, M., et al., *Dielectric properties of water and water/ethylene glycol mixtures for use in pulsed power system design*. Proceedings of the IEEE, 1986. **74**(9): p. 1182-1221.
- [11] Komarov, V., S. Wang, and J. Tang, *Permittivity and measurements*. Encyclopedia of RF and microwave engineering, 2005.

Acknowledgement

This research has received funding support from FRGS (ref: FRGS/2/2014/TK06/CURTIN/02/1).