

Citation

Love, P. and Zhou, J. and Matthews, J. and Lavender, M. and Morse, T. 2018. Managing rail infrastructure for a digital future: Future-proofing of asset information. Transportation Research Part A: Policy and Practice. 110: pp. 161-176. <http://doi.org/10.1016/j.tra.2018.02.014>

Managing Rail Infrastructure for a Digital Future: Future-Proofing of Asset Information

Peter E.D. Love^a, Jingyang Zhou^b, Jane Matthews^c, Matthew Lavender^d, and Troy Morse^e

^a School of Civil and Mechanical Engineering,
Curtin University, GPO Box U1987, Perth, 6845 WA, Australia
Email: p.love@curtin.edu.au

^b School of Civil and Mechanical Engineering,
Curtin University, GPO Box U1987, Perth, 6845 WA, Australia
Email: j.zhou@curtin.edu.au

^c School of Built Environment,
Curtin University, GPO Box U1987, Perth, 6845 WA, Australia
Email: jane.matthews@curtin.edu.au

^d School of Built Environment,
Curtin University, GPO Box U1987, Perth, 6845 WA, Australia
Email: matthew.lavender@curtin.edu.au

^e Public Transport Authority
PO Box 8125, Perth Business Centre 6849, Perth WA, Australia
Email: troy.morse@pta.wa.gov.au

Managing Rail Infrastructure for a Digital Future: Future-Proofing of Asset Information

Abstract

Rail infrastructure that operates at its optimum will be economical and sustainable and thus positively contribute to the productivity and competitiveness of an economy. The health of rail infrastructure, however, needs to be monitored, measured and maintained, which falls within the remit of asset managers who are often charged with balancing costs, opportunities and risks against the desired performance of the assets and their respective systems at varying levels. Having appropriate and reliable information about an asset is pivotal for enabling asset management to support decision-making, planning and execution of activities and tasks of assets, particularly during operations and maintenance. But, having access to the right information at the right time, has been and remains a pervasive problem, hinders an asset owner's ability to ensure their rail infrastructure performance is being optimized. A new approach to facilitate the acquisition and integration of information to support digital asset management (DAM) for rail infrastructure is presented. The research uses a case study to empirically assess the quality of 'as-built' documentation for electrical systems of Bayswater railway station that forms an integral part of the Forrestfield Airport Linkage project, in Perth Western Australia. Errors, omissions and information redundancy contained within the existing 'as-built' documentation is quantified. Then, a case for the adoption of a Systems Information Model is put forward as the rail industry moves toward a digital future and seeks to future-proof their assets and networks.

Keywords: Asset management, digitization, system information model, rail, future-proof

1.0 Introduction

“The best way to predict the future is to create it” (Peter Drucker)

Rail forms a critical part of the transport infrastructure cadre that is needed to service and improve the productivity and performance on an economy (ARA, 2015). The construction of resilient rail assets and networks that are able to withstand or recover swiftly from demanding conditions and unexpected events is essential for ensuring their future-proofing. In response to climate change and the need to obtain economic efficiencies throughout an asset’s life, many governments worldwide have begun to embark on a process of future-proofing. But, the design, construction and maintenance of resilient rail assets and networks that are able to cope with foreseeable risks are a challenge. Presenting an even greater challenge are those risks that are difficult or even impossible to foresee. Such risks arise from low-probability, but potentially have severe consequences materialising from complex interdependent processes with wicked uncertainties (Blockley, 2015).

Wicked problems are difficult or impossible to solve because of incomplete, contradictory and changing requirements that are often difficult to recognise. Climate change has been identified as a wicked problem for Australian governments (Verweij, *et al.*, 2006; NCCARF, 2013). The traditional approach to policy development (i.e. an orderly and linear process, working from problem to solution) is therefore inadequate to deal with such problems, particularly the future proofing process (APSC, 2012). For governments, the climate change problem has many interdependencies that are often multi-causal (NCCARF, 2013). Thus, to address this wicked policy problem, particularly in the context of future proofing rail infrastructure, there is a need for a coordinated and interrelated response, given its multi-causal nature. The Australian public sector has acknowledged that to address issues surrounding climate change and ensure assets are future proofed there is a need to stimulate and nurture innovation (APSC, 2012).

Recognising the increasing complexity and the role that the private sector can play in providing innovative solutions to future proof rail infrastructure, particularly during the design process, governments have embraced non-traditional procurement strategies to deliver their assets (Love *et al.*, 2017a). For example, an alliance with a contract value of AU\$600 million was used to deliver the works between Southern Cross Station and Hopkins Street, Footscray, as part of the State government’s strategy to provide improve links between Melbourne and

Maribyrnong River in regional Victoria. Juxtaposed with the use of non-traditional procurement strategies, governments have also turned to adopting technological innovations enabled by digitisation such as Building Information Modelling (BIM), to generate, build and manage rail infrastructure data throughout their lifecycle. For instance, the New South Wales Government mandated the use of BIM on AU\$8.3 billion Sydney's Northwest Metro project to reduce construction and maintenance costs. Similarly, London's £14.8 billion Crossrail project in the United Kingdom (UK) is relying on the use of BIM to create a field verifiable 'as-built' models that can be used to effectively and efficiently manage assets and the network during its operations and maintenance.

While many governments worldwide are actively addressing the future-proofing process, there is a paucity of empirical evidence to indicate that the use of non-traditional project delivery mechanisms and digitization can provide cost efficiencies and value for money throughout an asset's lifecycle, especially for rail infrastructure (Love *et al.*, 2017a;b). Indeed, a complex network of issues need to be considered when addressing the wickedness associated with future proofing of rail infrastructure, but unless fundamental problems are addressed, then attempts to redress them by governments will remain futile unless policy is challenged and amended to accommodate future practice.

In concordance with the recommendations provided in numerous Australian government initiated reports (e.g., Productivity Commission, 2014; Infrastructure Australia, 2016) and drawing on the authors phenomenological research (Liu *et al.*, 2016; Liu *et al.*, 2017), non-traditional procurement methods are well positioned to drive innovation and the change needed to develop resilient and adaptable rail infrastructure. While headway is being made in developing policy to ensure the resilience of rail infrastructure, the approach being adopted remains somewhat linear in nature, particularly the way in which the information needed to effectively manage, operate and maintain assets is acquired. The upshot is rail infrastructure vulnerability, which can have physical, social and economic consequences, especially when electrical systems are defective, malfunction or are damaged. Simply put, without a power supply rail networks are unable to operate, which will reverberate adverse economic and social corollaries throughout an economy.

Against this contextual backdrop, the research presented in this paper makes a contribution to the future proofing of rail infrastructure by empirically demonstrating that the prevailing

approach to documenting and managing information for electrical systems is ineffective and can result in a quagmire whereby the asset's integrity is jeopardised. This is undertaken using a case study of the existing Bayswater railway station that forms an integral part of the Forrestfield Airport Link (FAL) project. Rather than simply propagating a solution that the Public Transport Authority (PTA) in Western Australia (WA) should adopt in the future to tackle the issues surround the management of information, an innovative way to document and manage electrical information that is enabled by digitization using a Systems Information Modelling (SIM) is presented. The potential productivity and information management benefits enabled by using SIM were acknowledged by the PTA. A decision was taken to embrace SIM, which has provided the PTA with a catalyst to enact changes to their work practices.

2.0 Toward Digital Asset Management

Large-scale capital intensive rail infrastructure projects are susceptible to experiencing increases in their capital expenditure¹ (CAPEX) (Love *et al.*, 2017b). In Australia, for example, the Gold Coast light rail has been reported to run approximately AU\$350 million over budgeted CAPEX (Coulton, 2016) and the Perth to Mandurah rail project an increase well in-excess of \$250 million (Spagnolo, 2007). Research undertaken by Love *et al.* (2017b) revealed that CAPEX increases from the award of construction contracts were predominately due to change orders. Equally, it has been revealed by Crossrail (UK) that an increase of £1 billion to the tier 1 contracts will be incurred due to design changes and low initial bids were received during low levels of construction activity within the marketplace (Prior, 2017).

2.1 Information Quality at Hand-over

Design changes and errors and omissions in documentation that are identified after the award of contract not only contribute to increasing CAPEX, but can also adversely affect OPEX. Such changes require working drawings and specifications to be amended and updated during construction. Thus, at the practical completion of a rail project the 'as-built' documentation that was handed-over should reflect what has been actually constructed and installed. In many instances, however, 'as-built' documentation is of poor quality; that is, not being fit for its intended use.

¹ Terrill and Danks (2016) examination of 836 transport projects between 2001 and 2015 revealed large cost overruns are uncommon, but when they do occur they can be expensive. That is, 90% of the total of cost overrun that was experienced for the sample, in dollar terms, was attributable to only 17% of projects.

‘As-built’ documentation has been typically provided to asset owners in paper format. The ‘as-built’ are often provided when the asset is already in use and then placed in storage where they are difficult to access. According to Gallaher *et al.* (2004) “an inordinate amount of time is spent locating and verifying facility and project information from previous activities. For example, ‘as-built’ drawings (from both construction and operations) are not routinely provided and the corresponding records of drawings are not updated. Similarly, information on facility condition, repair parts status, or a project’s contract or financial situation is difficult to locate and maintain” (p. 121). Moreover, information is often contained on several documents (e.g. drawings, data sheets and test sheets), which can render the search for information during maintenance and operations to be a difficult process that adversely impacts productivity.

Many asset owners have computer maintenance management systems (CMMS) and computer asset management systems (CAMS) in place, and thus the information contained within the test sheets, vendor information, maintenance data, and the like, which forms an integral part of ‘asset-built’ documentation, needs to be transferred into these systems (Teicholz, 2013). Traditionally this has been a manually-laden process, which is a costly and time consuming exercise. But notably, the CMMS/CAMS are often not utilised until they contain all the necessary data and have been checked for accuracy and completeness (Teicholz, 2013). Considering the poor quality of ‘as-built’ documentation that is generally provided at handover, the cost and time associated with having to enter, verify and up-dating information into these systems can be phenomenal for asset owners and operators (Gallaher *et al.*, 2004).

2.2 Digitization

With the increasing shift toward the digitization² of rail infrastructure, which is being enabled by the developments in BIM and used on flagship projects such as Crossrail (UK), greater emphasis has been placed on improving the quality of information that is made available at handover. Governments and their transport agencies worldwide, in particular Australia, can learn valuable lessons from the experiences at Crossrail. One strikingly important lesson that has been identified and pertinent to the research being presented in this paper, is the need to prescribe at the onset of a project the long-term maintenance requirements to contractors so as to establish a philosophy of repair rather than failure (Wiggins, 2016). This would, however,

² The process of converting information into a digital format

require asset managers to have be actively involved in the design process and specifying the information needed to engender such a philosophy.

Thus, to capture the requirements for maintenance when using BIM, Love *et al.* (2015a) stated that there is a need to ‘think of end at the beginning’ and implementing international standards such as Construction Operations Building Information Exchange (COBie) for managing information in a digital format (e.g. BS 1192-4:2014). For this to effectively occur requires a major shift in the policies used to procure rail infrastructure, as asset managers³ would become the ‘champions’ of the future proofing process. In doing so, they would responsible at project’s onset for identifying, structuring and managing the information needed to ensure assets are effectively and efficiently maintained and the rail network operates with minimal disruption and downtime.

The digitization of electrical systems in rail infrastructure projects has been generally overlooked as emphasis has been placed on those elements that possess geometry (Love *et al.*, 2016). In part this may be attributable to the delay in the development and approval of standards for managing electrical⁴ information in a digital format, but also due to the absence of an effective object oriented modelling approach that can accommodate the complexity associated with electrical systems that have no geometrical properties.

To enable the digital asset management (DAM) of electrical systems for rail infrastructure, Love *et al.* (2016) have revealed that the use of System Information Model⁵ (SIM) in conjunction with three-dimensional (3D) model can potentially ensure the integrity of the information required for operations and maintenance. In addition, Love *et al.* (2016) have suggested that a SIM can improve productivity and make a positive contribution to reducing costs throughout an asset’s life-cycle.

³ Asset management “involves the balancing of costs, opportunities and risks against the desired performance of assets, to achieve an owners’ objectives. It also enables asset owners to examine the need for and performance of their assets and their respective systems at varying levels. Having appropriate and reliable information about an asset (e.g. product data, warranties and preventative maintenance schedule) is essential to support decision making, planning and execution of activities and tasks on assets, particularly during operations and maintenance”. (Love *et al.*, 2015)

⁴ East (2013) has developed an initial COBie format for electrical systems referred to as Sparkie.

⁵A generic term used to describe the process of modelling complex connected systems. System information models are digital representations of connected systems, such as electrical instrumentation and control, power and communication systems. The objects modelled in a SIM have a 1:1 relationship with the objects in the physical system. Components, connections and functions are defined and linked as they would be in the real world.

3.0 Illustrative Case Study

In recognition of the need to digitize information during the design and construction of infrastructure assets so that assets can be better managed during their operations, several countries such as Denmark, Norway, UK, Singapore and South Korea, have mandated the use of BIM on major capital projects that exceed a specific monetary value (Singh, 2017). While the adoption of BIM is transforming the nature of work in construction and has been widely espoused to provide significant economic, environmental, and social benefits, they have yet to be empirically quantified (Love *et al.*, 2016). Notably, however, Sacks and Barak (2008) observed that switching from two-dimensional computer-aided drafting to the use of parametric three-dimensional modelling to design and detail a reinforced concrete building structure a productivity improvement of 15% to 41% could be achieved. The derivation of the quantifiable benefits of technology, such as BIM, provides the underlying business case for its adoption to be established. This line of inquiry is also applicable for a SIM, which takes a discipline specific perspective that can be integrated with BIM to form a consolidated point of truth (POT) (Love *et al.*, 2016).

A case study is a research strategy that aims to engage in a process of empirical inquiry that investigates a phenomenon within its real-life context (Yin, 2014). According to Gerring (2005) they can be used to specifically address questions that focus on explaining ‘how’ and ‘why’ phenomena occur. In this instance, the research focuses on how to future proof rail assets and ensure that networks are not placed in a position of vulnerability as a result of poor information quality. Under the auspices of an illustrative case study, which is descriptive in nature and seeks to make the ‘unfamiliar familiar’ with a new concept (Stacks, 2013; Yin, 2014), the research commences by empirically quantify the prevailing issues adversely impacting the creation and management of information of electrical assets. In doing so, the authors provide a justification for ‘why’ a SIM should be adopted, which then provides a springboard to demonstrate ‘how’ it can be implemented in practice.

3.1 Case Selection

As part of a continuous improvement strategy, the PTA recognised that they needed to redress their asset management processes and procedures by embarking on a journey of digitization. The PTA had been made aware of the potential use of a SIM to enable the DAM of rail assets from the exploratory research presented in Love *et al.* (2016). To examine the potential

application of the SIM, an important station needed to be identified. Due to issues of commercial confidentiality stations under-construction could not be considered, thus the PTA selected the existing Bayswater Station (Figure 1), as it formed an integral part of FAL that is under construction. The FAL connects with the existing Midland Line near Bayswater Station and will run to Forrestfield through an underground tunnel, ensuring minimal impact on the existing land and road network. The AU\$2 billion State Government-funded FAL aims to improve connections to and from Perth Airport, the eastern suburbs and regional centres. Three new stations to the suburban rail network – Belmont, Airport Central and Forrestfield will be constructed (Figure 2).

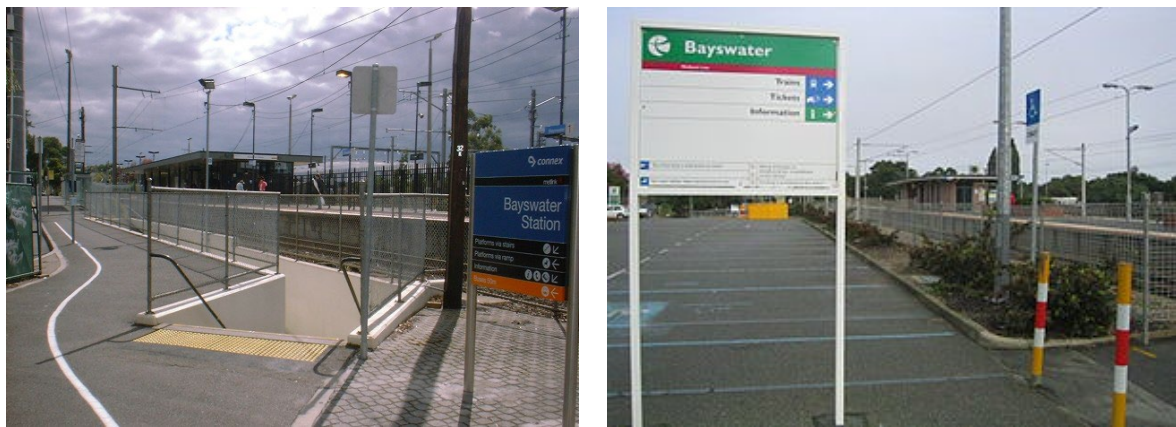

Figure 1. Bayswater Station: Midland Line



Figure 2. The Forrestfield Airport Link (under construction)

The Bayswater Station was divided into four main zones: (1) Carpark North; (2) Platform; (3) Carpark South; and (4) Pedestrian Underpass (Figure 3). The Platform was further subdivided into three areas: (1) West Side; (2) Building; and (3) East Side.

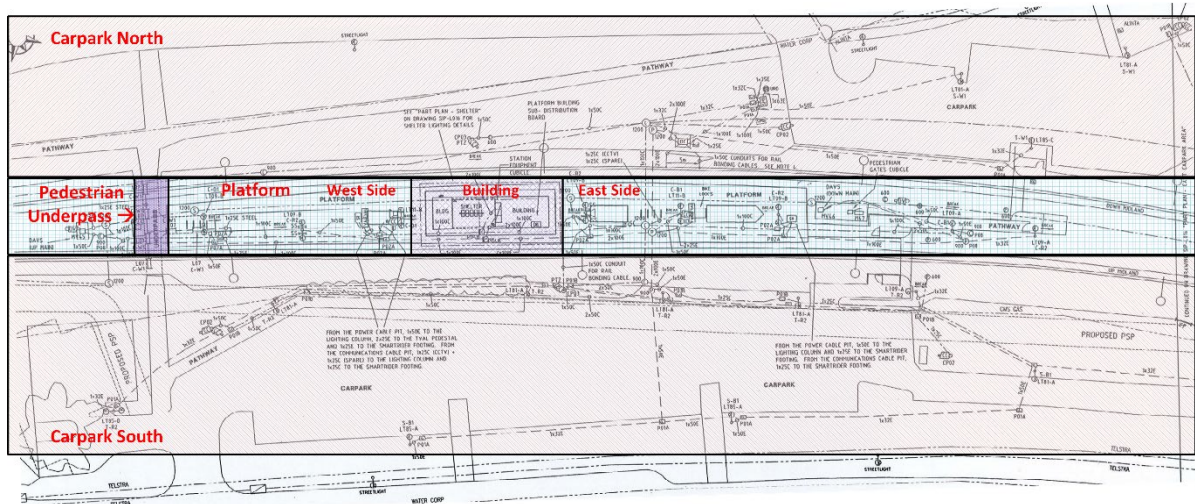

Figure 3. Bayswater station zoning

The Building consists of a shelter, which is an undercover area for the passengers and an equipment cubicle where the Information, Emergency, and Ticketing Bays reside as well as other assorted electrical equipment.

3.2 Data Collection

Case study research relies on the use of multiple sources of data. In this case, the data was obtained from site visits, informal discussions with electrical engineers and asset managers, and documentation. The PTA supplied a total of 30 engineering ‘as-built’ drawings that documented the electrical, control and monitoring system designs for Bayswater Station (Table 1). The majority of the electrical engineering drawings had been created in September/October 2003 by electrical engineering contractors. Several drawings were produced between February and May 2002 and later modified in 2003 and 2004. Noteworthy, the last time the drawings for this station had been updated was 21/02/2006.

Table 1. Classification of ‘as-built’ drawings

| Type | Drawing Number | Number of Drawings |
|-------------------|--|--------------------|
| Cover Page | N/A | 1 |
| Layout | SIP-L015, SIP-L016, SIP-LG32, SIL-LG34, SIP-LG35, 0502027, 0502029, 0502030, 0502021, SR-036, RACK-BAY, SIP-TV05 | 12 |
| Schematic | SIP-LG26, SIP-LG33, SIP-LG36, 0502019, SIP-LG037, 0502026, 0502028, 0502022, 0502023, 0502024, 0502025, BAY-CCTV | 12 |
| Single line | 0502018, 0502020, USIP-SUCS-04 | 3 |
| Legend of symbols | 0502031 | 1 |
| Cable schedule | 0502032 | 1 |
| Σ | | 30 |

Two sets of drawings were created by different electrical engineering contractors and conflicting information was contained in the schematics. For example, the schematic drawings both described the monitoring system termination details for the station. One set of schematics were completed on 17/09/2003 and approved on 18/09/2003. However, the other set was completed on 22/10/2003, but was not approved. A detailed examination of the drawings revealed an array of anomalies and errors, which are identified below.

4.0 Empirical Evidence: Quality of ‘As-Built’ Drawings

Using the Dynamic Asset Data (DAD) software, a SIM was retrospectively created for the electrical, control and monitoring systems for the Bayswater railway station. During the modelling process, numerous errors and omissions contained within the ‘as-built’ drawings were identified. The following sections examine the quality of the ‘as-built’ drawings provided. Then, the potential of using SIM instead of computer-aided-design (CAD) to design, document and manage asset information is examined.

4.1 Numbering and Labelling

Most of the electrical equipment presented on the drawings had been incorrectly numbered. A total of 115 components had been identified as being installed in the ‘Site Main Switchboard’ (SMSB), ‘Isolation Transformer Cubicle’ (ITC) and ‘Platform Distribution Board’ (PDB). However, only 29 of them are labelled on the drawings, these primarily being relays, contactors, earth bars and neutral bars. Many components on the drawings did not

follow a standard labelling convention and possess a unique identifier (ID). For instance, six hood and two internal lights in the ‘Station Equipment Cubicle’ had not been labelled. A list of the ceiling and ground lightings are presented in Table 2 which shows a summary of their location and assigned tag names. Notably, several of the lights shared the same tag name. For example, four ceiling lights in the shelter were labelled as L05B. Twelve ceiling lights in the station building were named L05C and nine ground lights in the car park are named as LT81-A. Thus, multiple components shared the same tag name and therefore caused a considerable amount confusion when trying to locate them during the maintenance process.

Table 2. Location of lighting and labelling

| Types | Locations | Tag Names | Numbers of Lights |
|----------------|------------------------------------|------------------|--------------------------|
| Ceiling Lights | Platform\Building\Shelter | L05B | 4 |
| | Platform\Building | L05C | 12 |
| | Pedestrian Underpass | L07 | 6 |
| Ground Lights | Carpark South & Platform\East Side | LT09-A | 3 |
| | Platform\East Side & West Side | LT09-B | 4 |
| | Platform\East Side & West Side | LT11-B | 2 |
| | Platform North & Carpark South | LT81-A | 9 |
| | Carpark North | LT83-A | 1 |
| | Carpark South | LT85-A | 4 |
| | Carpark South | LT85-B | 1 |
| | Carpark North | LT85-C | 1 |

A similar scenario existed with the labelling of information for the pit system. A total of 33 pits were identified from two drawings: 12 communication and 21 power cable pits (Table 3). Again, multiple components shared the same label. For example, P01A was assigned to 11 (one communication and 10 power) and P01B was assigned to 12 different pits (7 communication and 5 power).

Table 3. Pit classifications and labelling

| Labels of Pits | Numbers of Pits | | Σ |
|-----------------------|------------------------|-------|----------|
| | Communication | Power | |
| P01A | 1 | 10 | 11 |
| P01B | 7 | 5 | 12 |
| P02A | 3 | 4 | 7 |
| P04B | 1 | 1 | 2 |
| P | 0 | 1 | 1 |
| Σ | 12 | 21 | 33 |

Besides the components, cables also require a proper numbering system which should contain information about their termination, type and ID. An example of a proper cable numbering system is presented in Figure 4. A cable schedule provides detailed design information such as their destinations, types, ratings, and the number of cores. Cable schedules are typically used by engineers on-site to terminate cables instead of drawings.

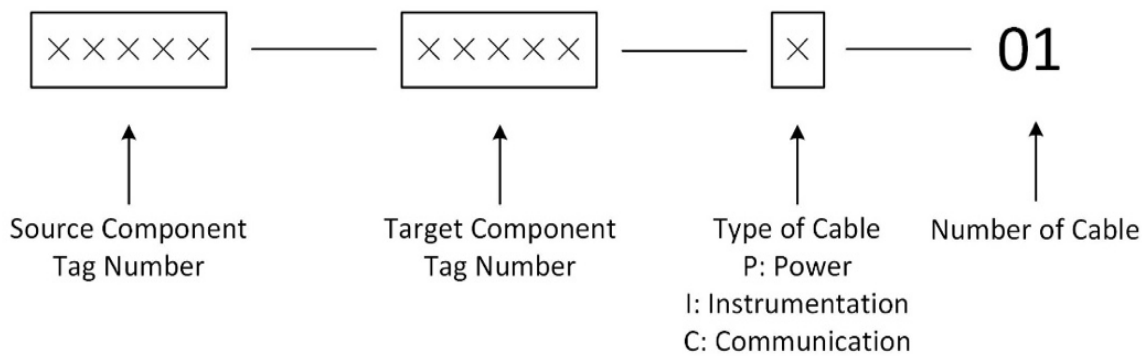

Figure 4. Example of cable numbering

During the modelling process, multiple examples of incorrect labelling and a lack of standardised numbering were unearthed throughout all the ‘as-built’ schematic drawings. For example, a:

- communication cable between SMSB and the Programmable Logic Controller (PLC) terminals was labelled as ‘SMSB’, rendering it not possible to identify the cable’s type and its destination;
- power cable from the ‘Platform DB’ to the Hood Lighting (HL) of the Station Equipment Cubicle was labelled as R8-LH. In this case, R8 represents a circuit number (not a source component) that is fed from the ‘Platform DB’ to the HL. However, there were six HLs in the Station Equipment Cubicle (two in each bay), which are unable to be powered up by a single cable. Thus, multi-cables with different number are required instead;
- control cable between the ‘Passenger Information Interface’ (PIN Interface) and PLC terminal block TB-PLC5 was named as PLC-PIN. In this instance, the names of the two destination components were used to construct the tag name of the cable. However, the cable type was not specified and its number not defined; and

- cable between the PLC terminals and the PLC modules was named in the form of ‘PLC-Number’. Here the ‘Number’ represents the portal number of the PLC module. The cable number did not contain the information needed to identify the PLC terminal and its type.

In addition, it was revealed that critical design information had been omitted from the drawings. For example, the ‘as-built’ drawings did not specify the lighting manufacturer and power rating that were required. A similar situation was found to exist for an array of components such as the uninterruptible power supply (UPS), circuit breakers and isolators. In addition, no information was presented on a drawing indicating the components that were connected to the terminal strips behind the Rack Distribution panels. Several drawings made reference to other drawings, which were not made available or had been misplaced (Table 4). For example, drawing SIP-LG04 referred to SIP-LG33, and SIP-LG28 and SIP-LG30 were referenced on SIP-LG26. From Table 4 it can be seen that a total of 25 drawings were missing from the set provided, which were referenced on 11 different documents.

Table 4. Summary of missing drawings

| Missing Drawings | Referenced on |
|--|----------------------|
| SIP-LG00, SIP-LG01, SIP-LG02, SIP-LG03, SIP-LT00 | SIP-L015 |
| SIP-LG28, SIP-LG30 | SIP-LG26 |
| SIP-LG31 | SIP-LG32 |
| SIP-LG31 | SIP-LG34 |
| SIP-LG31 | SIP-LG35 |
| SIP-LG04, SIP-LG31, SIP-LG38, SIP-LG39 | SIP-LG36 |
| SIP-LG04, SIP-LG31 | SIP-LG33 |
| SIP-LG04 | SIP-LG37 |
| 0502010 | 0502029 |
| SIP-LG06, SIP-LG07, SIP-LG08, SIP-LG09, SIP-LG10, SIP-LG12, SIP-LG13, SIP-LG14, SIP-LG15, SIP-LG16, SIP-LG41, SIP-LT11 | SIP-TV05 |
| SIP-TV-100 | Bay-CCTV |

4.3 Errors and Conflicts

A number of errors and conflicts were identified on the ‘as-built’ drawings. For example, on one drawing a camera had been installed on the east side of Carpark North. However, there was no information denoting its power source and there was no pit in the immediate area. On another

drawing the 3rd and 4th terminals of a monitoring junction box (JB) were marked as being spare. But, on another drawing the two terminals were identified as being used for the ‘Station Main Switch Trip Indication’. In another case, the rating of the circuit breakers for the lighting circuits, which are shown on a schematic (Figure 5a) was different from that defined in the ‘Schedule of Circuits’ (Figure 5b). Here a rating of 16A was denoted on SIP-LG37 (Figure 5a) and 20A in the ‘Schedule of Circuits’ on SIP-L016 (Figure 5b). By comparing the ratings of the lighting circuits in other cabinets, it is assumed that the information on SIP-L016 is more likely to be correct. It was also observed that the design of the UPS bypass circuit differed between the drawings SIP-LG37 and 0502028 (Figure 6).

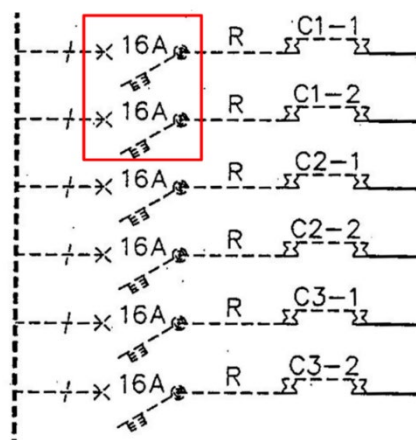

(a) Circuit breaker rating on SIP-LG37

| CIRCUIT NUMBER | SWITCHBOARD | MCB RATING | CABLE SIZE | SWITCHING CONTACT | FUNCTION |
|----------------|-------------|------------|----------------------|-------------------|---------------------|
| S-W1 | SHB | 20A | "EXISTING" | C1-1 | N. CARPARK LIGHTING |
| S-B1 | SHB | 20A | 2x4sqmm + E Cu TPS | C1-2 | S. CARPARK LIGHTING |
| T-W1 | ITC | 20A | 2x4sqmm + E Cu TPS | C1-3 | N. CARPARK LIGHTING |
| T-R2 | ITC | 20A | 2x4sqmm + E Cu TPS | C1-1 | S. CARPARK LIGHTING |
| T-R6 | ITC | 16A | 2x4sqmm + E Cu TPS | N/A | PEDESTRIAN GATES |
| C-W1 | PLATFORM DB | 20A | 2x2.5sqmm + E Cu TPS | C1-1 | UNDERPASS LIGHTING |
| C-B1 | PLATFORM DB | 20A | 2x4sqmm + E Cu TPS | C1-2 | PLATFORM LIGHTING |
| C-R2 | PLATFORM DB | 20A | 2x4sqmm + E Cu TPS | C1-3 | PLATFORM LIGHTING |
| C-W2 | PLATFORM DB | 20A | 2x2.5sqmm + E Cu TPS | C2-1 | SHELTER LIGHTING |
| C-W3 | PLATFORM DB | 10A | 2x2.5sqmm + E Cu TPS | N/A | TVAL - WEST |
| C-B3 | PLATFORM DB | 10A | 2x2.5sqmm + E Cu TPS | N/A | TVAL - EAST |
| C-UPS1 | PLATFORM DB | 10A | 2x2.5sqmm + E Cu TPS | N/A | DAVS - UP MAIN |
| C-UPS2 | PLATFORM DB | 10A | 2x2.5sqmm + E Cu TPS | N/A | DAVS - DOWN MAIN |

SCHEDULE OF CIRCUITS

SEE DRAWINGS SIP-LG33, LG36 AND LG37 FOR SITE MAIN SWITCHBOARD, ISOLATION TRANSFORMER CUBICLE AND PLATFORM DISTRIBUTION BOARD SCHEMATIC DIAGRAMS.

(b) Circuit breaker rating on SIP-L016

Figure 5. Circuit breaker rating on SIP-LG37 and SIP-L016

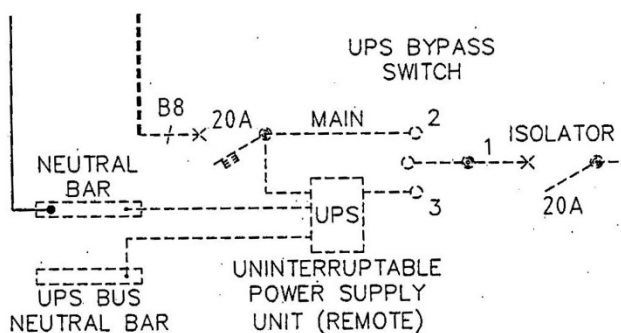

Design on SIP-LG37

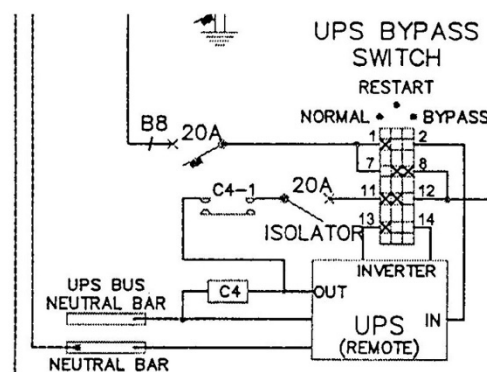

Design on 0502028

Figure 6. Design of UPS bypass switch on SIP-LG37 and 0502028

On a cabinet layout diagram and its corresponding schematic, it was observed that several of the manufacturers names were incorrectly labelled in the equipment schedule. For example, ‘KATCO’ should have been identified as ‘KATKO’. Similarly, ‘ELECTRA’ should have been labelled ‘ELEKTRA’. An examination of the layout drawing and the component schedule revealed that a ‘Double Power Point GPO’ should have been installed in the Rack DB panel (Figure 7a). However, from the photographs taken during a site visit, it was observed that only a ‘Single Power Point GPO’ had been installed (Figure 7b).

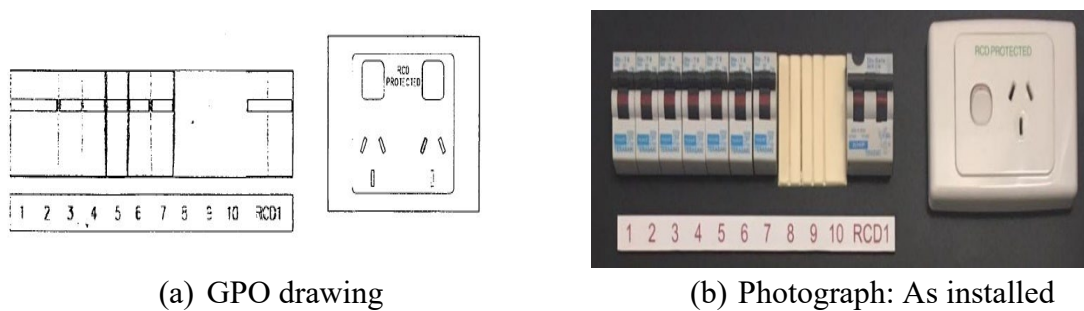
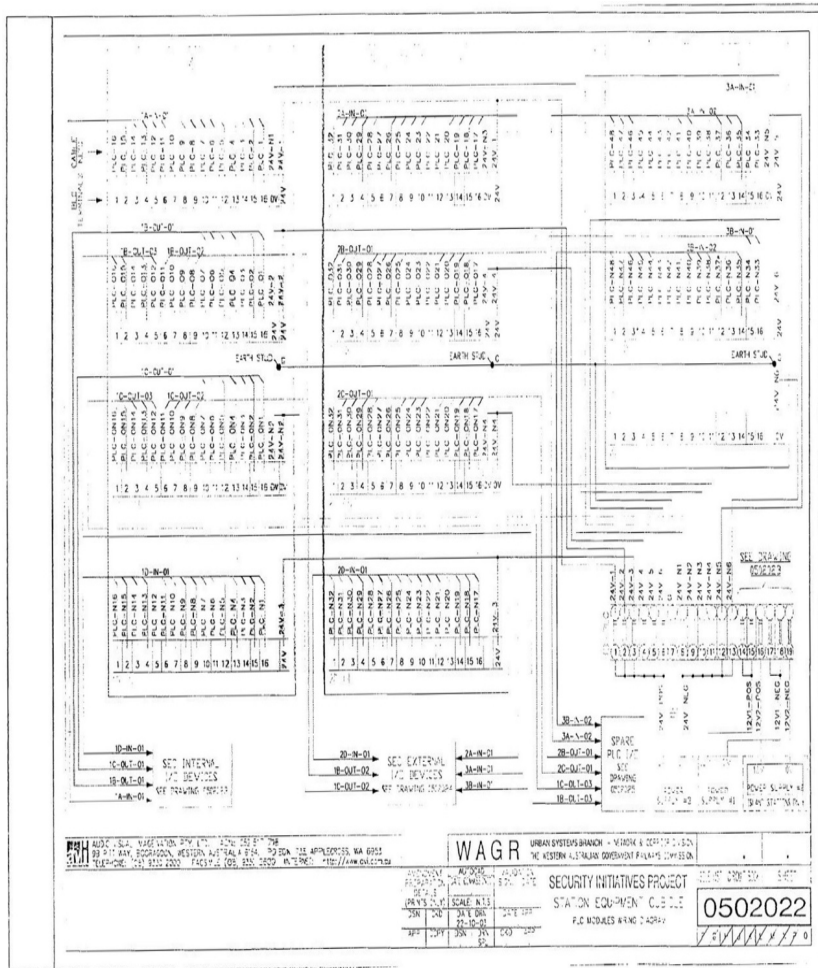

Figure 7. GPO: ‘As-built’ versus ‘as-installed’

The drawings that were provided were printed on A3 sheets. No digital CAD files were made available. The overall quality of the ‘as-built’ drawings was considered to be poor; words, symbols and lines printed on them are blurry and unclear. An example of the ‘as-built’ drawings provided is presented in Figure 8a. It can be seen that most of the lines, words and numbers are incomplete or are unable to be recognized. By comparing the information on several different drawings, the design of the PLC terminations was able to be recovered. The information missing from Figure 8a was manually redrawn and retraced and is presented in Figure 8b.

5.0 A Shift to the Digital Future

The ability to future-proof electrical assets is fettered when CAD based approaches are used to design and document them. Previous empirical studies in the resource and energy sectors have demonstrated that a SIM can significantly improve the efficiency and reduce the cost to document electrical systems by as much as 90% (Love *et al.*, 2013).



(a) Poor quality 'as-built'

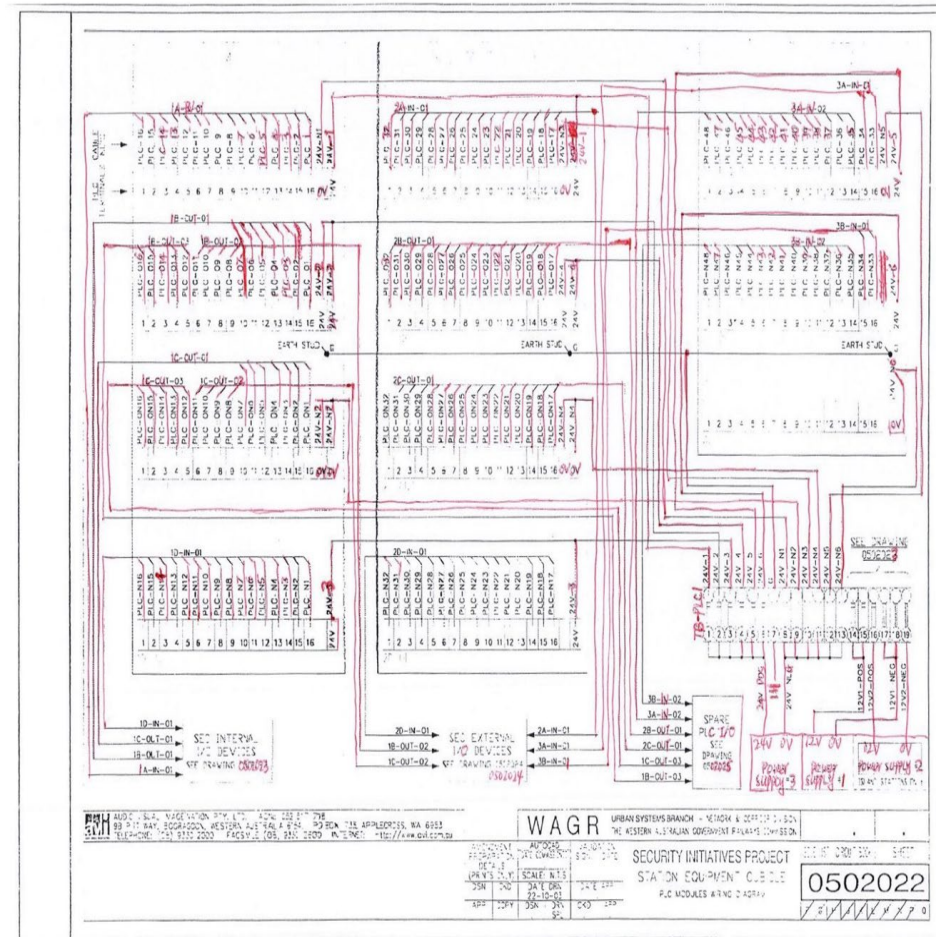

(a) Redrawn 'as-built'

Figure 8. Example of an 'as-built' provided for the study

According to Zhou *et al.* (2015) there is a need to shift from a position, where electrical asset information is produced using CAD in paper format and possesses a 1:n relationship, to an object-oriented approach where each physical object only needs to be modelled once. The corollary being the establishment of a 1:1 relationship between the real world and the digital model that is created. In addition, the data stored in a SIM is dynamically linked and therefore enable efficient management of the information. Engineers can therefore work collaboratively and concurrently on the same project model by creating the components and relationships among them. Thus, duplicated modelling of an identical device can be detected and avoided automatically. As each object modelled is allocated with a unique tag number, the problem of missing labels is eliminated. The effectiveness of using SIM to create the electrical information needed for asset management and engender the future-proofing is presented herein after.

The data needed for asset management needs to be collated during each phase of a rail project's life-cycle (Zhou *et al.*, 2015). As a result, such data can be accessed *via* seven functional portals that are aligned with an asset's life-cycle: (1) Design; (2) Review; (3) Publish; (4) Procurement; (5) Construction; (6) Commissioning; and (7) Operation.

5.1 Design Portal

The Design Portal forms the core of a SIM and is used here to retrospectively create a digital model based on the information extracted from the 'as-built' electrical engineering drawings. Noteworthy, when a SIM is adopted at the beginning of a project, a digital model can be gradually established by the engineering team as the design progresses. To create a SIM, two basic attributes are allocated to each individual component: (1) 'Type' and (2) 'Location' as noted in Figure 9a.

The 'Type' defines the functionality of the equipment and the 'Location' describes the physical position of the component within the plant. These two basic attributes provide a classification for the objects, which aligns with the common practices that have been adopted by many object-oriented software applications. Within a SIM environment, connections between components are modelled as connectors, which are classified according to their types.

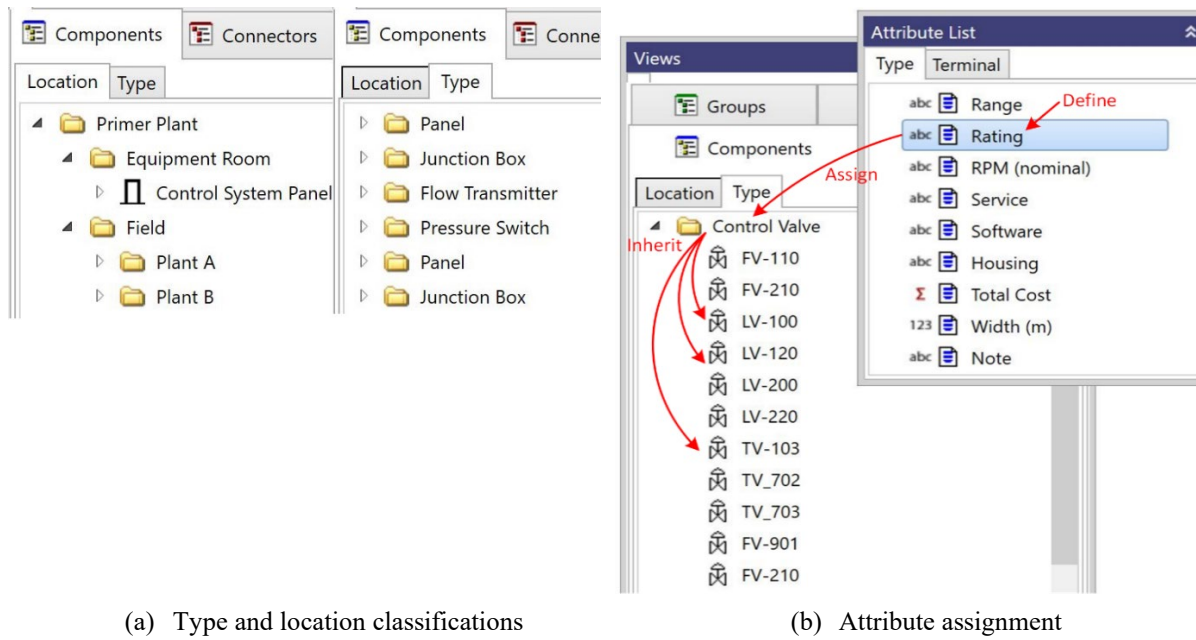

Figure 9. Basic attribute allocation for components

The components and connectors modelled in the SIM can be classified according to their functionalities. The root folders created under the ‘Components-Type’ tab identify a general classification of the component types. By expanding the root folders, the components can be further classified according to their specific functions. They can also be sub-classified based on a number of attributes such as manufacturer and component model. The type classification can be flexibly tailored to suit the specific requirements of the project. The classifications of components and connectors enable communication and interoperability between the SIM and other object oriented software applications through data exchanges.

As an object-oriented approach is used to create a SIM, information such as the component model, specification or serial number, can be assigned to each individual object through attributes, which are defined and made available to all objects. For example, an attribute ‘Rating’ can be defined in the SIM and assigned to different types of component such as an electrical motor, sensor or transmitter. Objects are structured hierarchically, which enables child objects to inherit attributes from their parent (Figure 9b). Moreover, documents, such as vendor manuals, or spreadsheets, can be linked to objects and made available to the related ‘children’. The components and connections can be modelled to ensure the data associated with them forms a digital connected system, which enables users to dynamically review design information. Within the SIM, the object with data attached forms a consolidated POT for the

corresponding physical object. As a result, errors, omissions and redundancies that often reside on paper drawings can be significantly reduced.

A ‘Group’ view is provided in the SIM, which enables users to create folders containing specific components and connectors to suit their particular information requirements. For example, users can create a filter for each folder created in the ‘Group’ view based on predefined criteria such as name, attribute value, and date. Then, the components/connectors matching the criteria can be automatically added to the target folder. When the filter rule is modified, the objects in the folder will be automatically updated reflecting the change that has been made. In this research, 30 ‘Group’ view folders were created corresponding to each of the engineering drawings that were provided. The pdf. files of the scanned drawings were uploaded to form a ‘Reference Library’ and linked to each individual ‘Group’ folder. As the modelling progressed, components and connectors identified on each drawing were added to the corresponding ‘Group’ folder. This can provide users with a clear view of the object distribution patterns within the SIM. For example, the number of times an object appeared on different drawings and their type. A link between the SIM data and the drawings can be established and therefore provide users with the ability to verify and correlate the design information between the two data sets.

5.1.1 Data: Attributes, Components and Connectors

The completed SIM contained 383 components and 649 connectors. Summaries of the components and connectors are presented in Tables 5 and 6, respectively. In Table 5 the electrical components accounted for a significant proportion of the total identified (75%). In addition, 58% of the components are located within the ‘Equipment Cubicle’ of the Platform’s Building. The ‘Equipment Cubicle’ contained the power distribution, control and monitoring systems. Table 6 presents the classification of the connectors according to their types. The power and control cables accounted for 80% of all the cables modelled. During the creation of the SIM, it was observed that cables were generally not named or numbered on the drawings. In recognition of this problem, an attribute for the connectors referred to as ‘Original Cable Name’ was created. Then, connector numbers, which were identified on the drawings, were recorded under this attribute. On completion of the SIM modelling, a filtered folder under the Group view was developed and the following filter rule implemented: “The attribute value for ‘Original Cable Name’ is not empty”. When the filter was applied, a total of 244 connectors

were added to the Group folder, which accounted for 38% of all the connectors that were modelled. This indicates that 62% of the cables were not numbered/named on the drawings.

An example of a block connection created in the SIM is presented in Figure 10. Here the power is fed from the 'Western Power Underground Supply Main' through the 'URD pillar' to the 'Site Main Switchboard' (SMSB). The SMSB supplies power to the Carpark North and South lightings. It also provides power to the 'Isolation Transformer Cubicle' (ITC) from where it supplies 'PDB', and 'Platform Sub DB' (PSDB), lights and electrical equipment. Three control cables (denoted in blue) are connected from the SMSB, ITC and PDB to the PLC Rack Panel, which is located in the Emergency Bay of the station's Equipment Cubicle. These cables are used to deliver the system monitoring data to the PLCs. The power for the PLC Rack Panel is supplied from the PDB.

Three layers are provided in a SIM to facilitate a system's design: (1) Block; (2) Termination; and (3) Diagram. Figure 11a presents a typical block diagram, which is used to present the general framework of the design and identify the relationships between components. A termination layer is used to illustrate how the cores of each individual cable are terminated at a device. For example, Figure 11b illustrates termination of a JB.

Table 5. Summary of components

| Component | Communication | Control | Cubicle | Electrical | Instrument | Metal | Monitoring | Pit | Rail | Service | Unknown | Σ |
|--------------------|----------------------|----------------|----------------|-------------------|-------------------|--------------|-------------------|------------|-------------|----------------|----------------|----------|
| Carpark North | 0 | 0 | 2 | 69 | 0 | 0 | 5 | 5 | 1 | 0 | 0 | 82 |
| Platform West Side | 0 | 0 | 1 | 10 | 0 | 0 | 4 | 4 | 0 | 0 | 0 | 19 |
| Platform Building | 9 | 14 | 3 | 182 | 10 | 1 | 2 | 2 | 0 | 1 | 0 | 224 |
| Platform East Side | 0 | 0 | 1 | 8 | 0 | 0 | 4 | 3 | 0 | 0 | 0 | 16 |
| Carpark South | 0 | 0 | 0 | 12 | 0 | 0 | 4 | 19 | 1 | 0 | 0 | 36 |
| Unknown | 1 | 0 | 0 | 5 | 0 | 0 | 0 | 0 | 0 | 0 | 0 | 6 |
| Σ | 10 | 14 | 7 | 286 | 10 | 1 | 19 | 33 | 2 | 1 | 0 | 383 |

Table 6. Summary of connectors

| Connector Type | Number of Connectors |
|----------------|----------------------|
| Power | 268 |
| Control | 256 |
| Communication | 14 |
| CCTV | 39 |
| Instrument | 1 |
| Busbar | 20 |
| Wire/Link | 44 |
| Future Cable | 4 |
| Unknown | 3 |
| Σ | 649 |

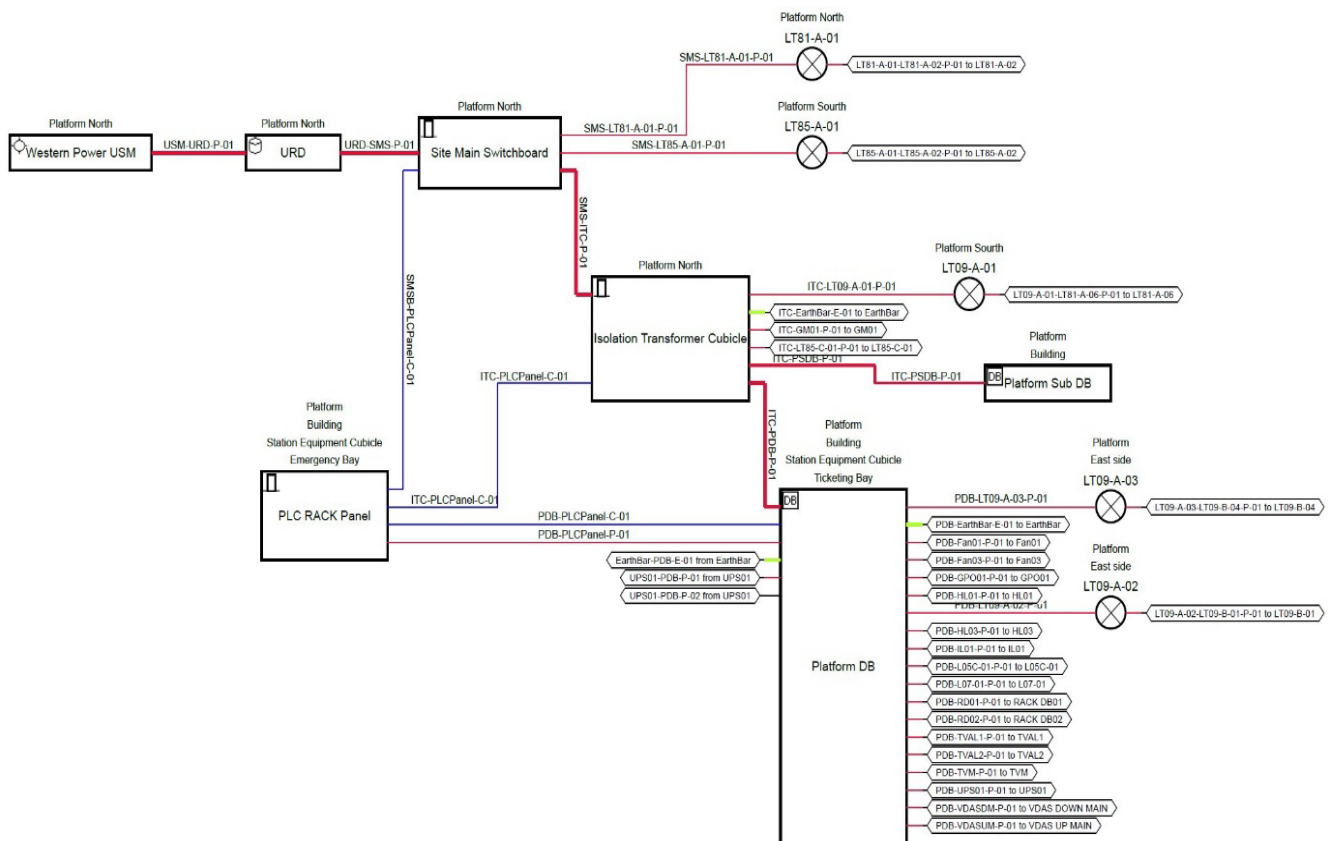

Figure 10. SIM block connection

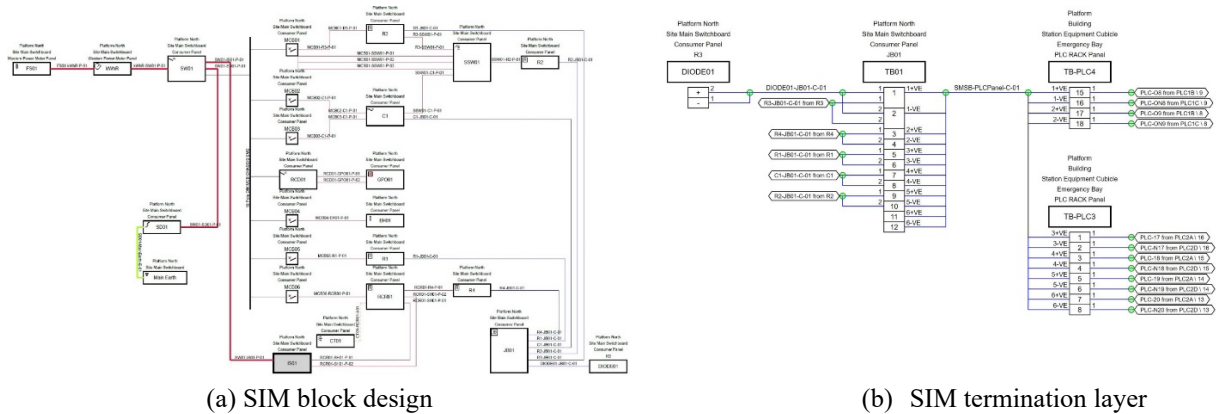

Figure 11. Examples of SIM layers

5.1.3 GIS Application

A SIM can support third party Geographical Information System (GIS) applications. A built-in function has been developed, which can enable users to add and edit the coordinate information for each modelled component. Routings can be defined for connectors between components indicating the paths of cables. The determination of cable length is a critical activity, which in the past has been a bane for electrical engineers. The installation of a cable requires it to be first cut off the drum, laid in a trench/ladder and then terminated. If the cable length is found to be too short, it must be dismantled before a new cable with the correct length can be installed, which will invariably delay the work. If a cable is too long, waste occurs thus increasing costs. Notably, there was no information about cable length provided on the 30 design drawings. This issue, however, can be addressed by using a ‘Routing’ function in conjunction with the SIM’s GIS support facility. ‘Pits’ used to route the cables were identified on the drawings. A pit marked with ‘C’ identified the communication cables and those identified with a ‘P’ were for power.

These pits were modelled in the SIM as components. Each of them was assigned a unique number. The coordinates of the components were acquired using Google Map and assigned to each component. Noteworthy, the derived coordinates are only estimates. To obtain an accurate solution, on-site Global Positioning System (GPS) measurement would need to be conducted. Then, each connector can be assigned with a cable route and take the following format:

Component (Entry) → Pit1 → Pit2 → … → Pitn → Component (Exit)

Figure 12a illustrates the circuit of power distribution from the SMSB, through the ITC, to the Carpark South lighting. For instance, the connector ITC-LT09-A-01-P-01, which joins ITC and LT09-A-01, is routed through three power pits and has a routing of ITC → P01B-P-01 → P01B-P-02 → P01B-P-03 → LT09-A-01. By allocating the coordinates to the components and assigning the route to the cable, a ‘Coordinates and Mapping’ function can be actuated, then Google Earth can be lunched. The locations of the electrical components, the pits and the joining connectors are instantly displayed (Figure 12b). The length of a connector can be obtained directly from Google Earth. In this case, the length of ITC-LT09-A-01-P-01 is measured to be 62 meters. This function is particularly useful for asset management, as it provides maintenance engineers with knowledge about the routing of an underground cable, the pits it passes through and its approximate length.

5.1.2 Linking Semantic and Geometric Information

The Bayswater Station was laser scanned by a third-party to retrospectively create a three-dimensional (3D) building information model in Autodesk® Revit (Figure 13a). Many of the components, such as lights, CCTV cameras and power poles were modelled to a high level of geometric detail (Figure 13b). But, such detail was not necessary, as it increases the size of the model (e.g., 210 MB) and the ability to use it. Much of the power of BIM is derived from the object-oriented nature of the model, which allows information about a component to be attached to a corresponding object. However, there were instances in the Bayswater model where several different components had been modelled as one object (Figure 13b).

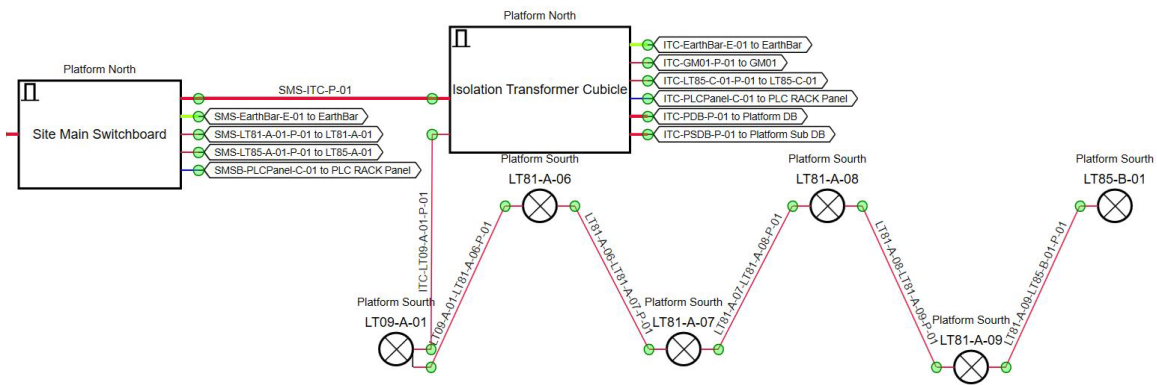

(a) South carpark lighting circuit

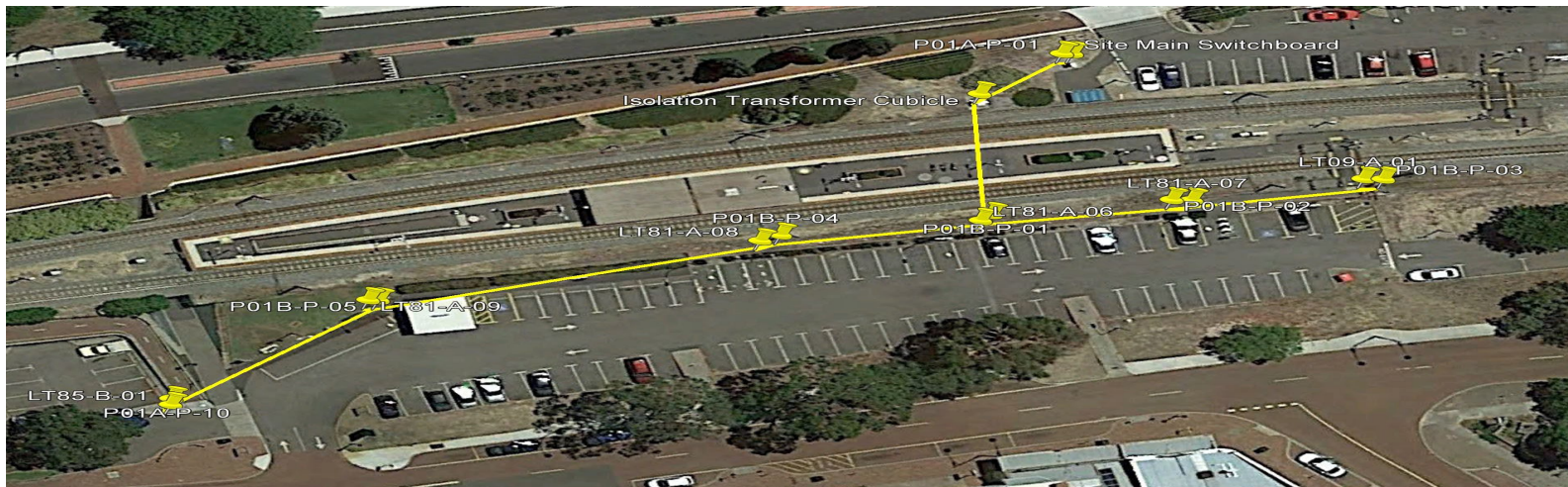

(b) Components and routing using Google Earth

Figure 12. Circuit of power distribution from the SMSB

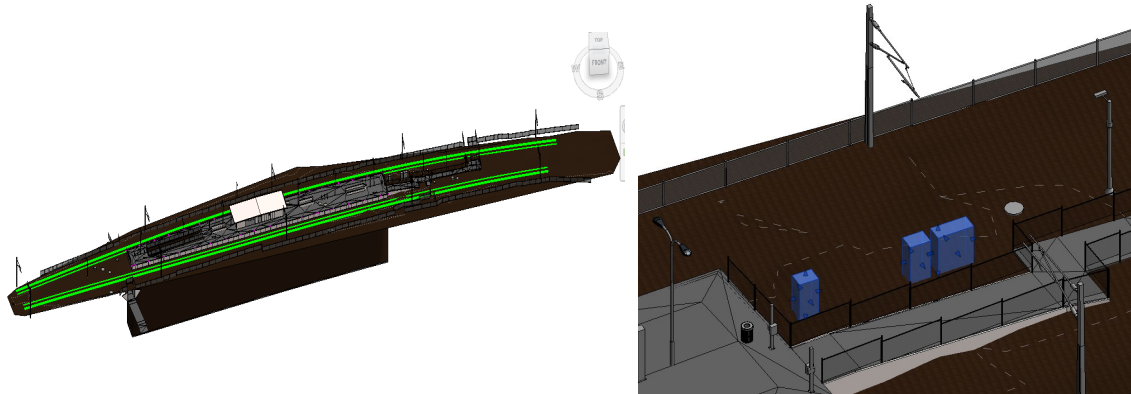

(a) Revit model of Bayswater Station

(b) Three individual components modelled as one object

Figure 13. Autodesk® model of Bayswater railway station

The structured data within a building information model can enable tasks such the creation of schedules to be automated. The robustness of this automation, however, is dependent on the quality of the data contained with the model. Many of the components had been modelled incorrectly. For example, an external light fixture had been modelled as a structural frame.

To ensure the SIM's integration with existing PTA software platforms it was linked to the building information model through the Industry Foundation Classes (IFC) data format (Figure 14). This is a neutral, open file format intended to describe building and construction data (Figure 14a). This means that the 3D model can be created in any BIM software, exported to an IFC file and opened in the IFC viewer in order to link with the SIM. The IFC viewer was developed using an open-source toolkit called xBIM⁶. It provides the ability to open, view and edit IFC files and is designed as an extensible toolkit for software developers. The xBIM functionality was programmatically extended to enable the IFC viewer to link to a SIM database in order to retrieve and display information (attributes) about a component when selected in the viewer (Figure 14b). The developed IFC viewer demonstrates the ability to link a SIM with building information model and is intended to show potential and stimulate further ideas rather than be a *fait accompli*.

⁶ xBIM is free to use and redistribute open-source toolkit is available at: <https://github.com/xBimTeam>

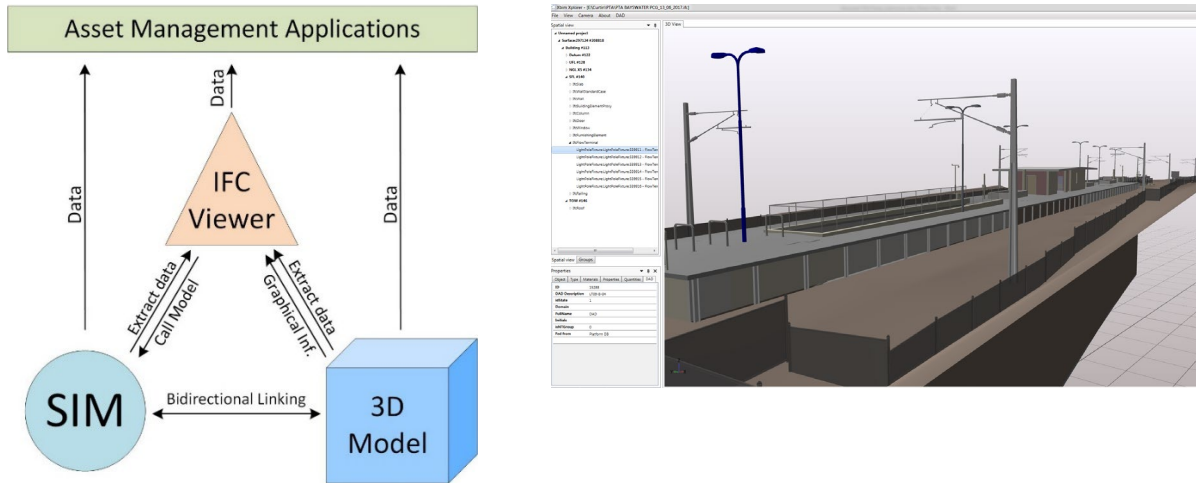

(a) SIM data linked to a 3D model using an IFC data format

(b) IFC viewer connection to a SIM

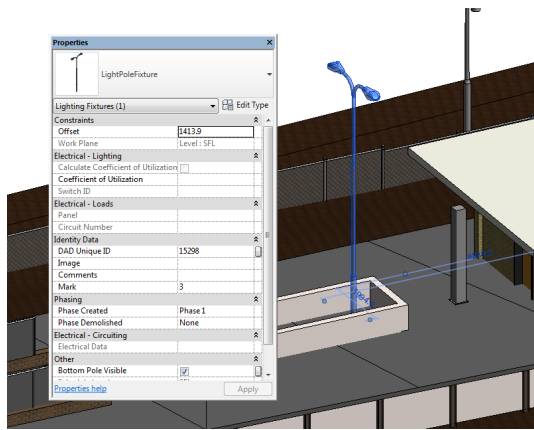

(c) Unique ID of a light

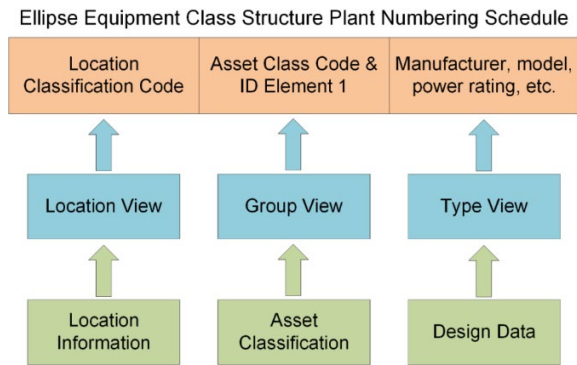

(d) Data structure for asset management

Figure 14. Linking semantic and geometric information

5.2 Review Portal

The Review Portal can be used to inspect the components and connectors created in the SIM. For the connectors, both the block and the terminal connections can be inspected. A status can be assigned to the component or connector once reviewed, which can be: (1) Pass; (2) Fail; (3) No Status; and (4) Not Applicable. In addition, comments and documents can be attached to objects that have been inspected.

5.3 Publish Portal

The Publish Portal is used to export the design information contained within the SIM to drawing sheets. Although publishing drawings is not recommended when a SIM is adopted, this function

is provided to cater for those who prefer or require them. Within the Publish Portal, users can choose the size of the drawing sheet, customize the title block and determine the type of information to appear on the drawing.

5.4 Procurement/Construction/Commissioning Portals

The functions provided in the Procurement, Construction and Commissioning Portals are identical. The workflow of the three portals follows the Plan, Do, Check and Act (PDCA) process. The Construction Portal is used as an example to introduce the functions enabled within each of them. In the 'Plan' stage of the Construction Portal, all of the activities needed to complete the project, such as 'install', 'test' and 'handover', are defined under the 'Activity Types' tab. Subfolders can also be created under each activity type, based on specific criteria such as type and location. The defined activities are assigned to tasks and allocated to work packages that are distributed to vendors and contractors. Tasks that are completed can be readily updated by an engineer within the SIM, which enables progress reports to be easily produced. For example, when a light is installed, an engineer can register the 'task' by using the 'Submit' button. Comments and person-hours worked can also be recorded. On submission, the task can be reviewed using the 'Check' function. Multiple-levels of checking can be enabled to suit the requirements of a project. A reviewer can either approve a task or reject it. If the task is rejected, it will be sent back to the contractor's engineer to review and redo. Tasks that have been approved are 'Acted' upon.

6.0 Enabling Digital Asset Management

The mapping between the SIM and PTA's asset management software system (Ellipse) enables the engineering and documentation data that would have been accumulated during design and construction process to be effectively transferred so it can be used during the operations and maintenance phase. To address the transfer of information, the following documents used by the PTA as part of its asset management policy were made available:

- Asset Reference Codes Register – Technical (8840-000-001) - details the Asset Reference Codes by location, Equipment Class and Element ID. Assets are categorised as: (1) Facility (Non-Trackside); (2) Facility (Trackside); (3) Facility Asset; (4) Trackside Asset (Non-Linear); and (5) Plant;

- Specification Asset Reference Codes (8840-000-002) - defines and explains the ‘Asset Reference Code Layout and Definition’ and ‘Asset Classification Structures’; and
- Asset handover equipment template –enumerates examples of the required data structures to be handed over for maintenance in the Ellipse System. Cables are excluded from the specifications. Thus, in this instance, the mapping created was only applicable to the equipment.

The asset types applicable to the SIM that were created for the Bayswater Station were: (1) ‘Facility (Trackside)’; and (2) ‘Facility Asset’. To maintain a component’s identity by its location and functionality, a unique identifier system was provided in 8840-000-002. Two types of Unique Identifier exist: (1) Structured Plant Number (SPN); and (2) Asset Tag. For the asset types ‘Facility (Trackside)’ and ‘Facility Asset’, Ellipse utilises an SPN identifier. The structures of SPNs for the ‘Facility (Trackside)’ and ‘Facility Asset’ are presented in Table 6.

The information structure of the SPN used to identify a component was based on its location and type, which is akin to a SIM. To enable the data to be exported to Ellipse, the SPN structure was is incorporated in the SIM. Two tiers of attributes were defined for the components modelled. Attributes of the first tier were defined under the SIM ‘Location View’ including ‘Line’, ‘Primary Location’, ‘Secondary Location’, ‘Tertiary Location’, ‘KKK.MMM’ and ‘Main Line’. The second-tier attributes were defined under the SIM ‘Group View’, which consist of ‘Equipment Class’ and ‘ID Element 1’.

Table 6. Structured plant number in Ellipse

| Asset Type | SPN Structure | | | | | |
|----------------------|----------------------|------------------|--------------------|-------------------|-----------------|---------------------|
| Facility (Trackside) | Line | Primary Location | Secondary Location | Tertiary Location | Equipment Class | Unique ID Element 1 |
| Facility Asset | Line | KKK.M MM | Primary Location | Main Line | Equipment Class | Unique ID Element 1 |

The location attributes were assigned to the corresponding location folders and their attribute values were set respectively. Then the children components contained within the folders automatically inherit the attributes and values from their parent folders. Within the SIM ‘Group View’, two ‘Group Folder’ hierarchies were created to match the structure of the ‘Equipment Class’ and ‘Unique ID Element 1’. The ‘Equipment Class’ was modelled as a root folder under

the 'Group View'. The 'Unique ID Element 1' was classified and created under each 'Equipment Class'. The folders were named after the 'Unique ID Element 1 Description' that was identified. Once the group folders were created, they formed a representation of the 'Asset Class' and 'Unique ID Element 1' that had been adopted by PTA. This structure can be conveniently modified/upgraded in accordance with changes that may be required to the PTA's 'Asset Classification'. In addition, it can be transplanted and re-used in other SIMs that the PTA may generate.

The two 'Group Attributes' that were defined are assigned to the corresponding group folders. The attribute values are taken from the lists of 'Asset Class Code' and 'Unique ID Element 1' provided in document 8840-000-001. When the group folders were ready, the corresponding components were then allocated according to asset types and classifications. Attributes were then automatically inherited. The asset information was distributed among three views: (1) Location, containing the location information and classifications of the components; (2) Type, where detailed design data such as model, series number, and manufacturer are included; and (3) Group, containing the information of asset classifications that complies with the PTA's 'Asset Reference Codes'. Figure 14d illustrates the developed data structure allocated within the three views.

The process to enable the DAM of electrical assets led to the identification of a number of issues for the PTA to address, but would also be pertinent to other transport agencies, namely, location coding and numbering of individual instances of a component type. If the DAM of electrical systems is to be wholly embraced and successfully future-proofed, then attention to the following is needed:

- production of guidelines, or templates for those creating the building information models that identify the objects to be modelled, and the level of geometric detail or semantic development where appropriate; and
- consideration of the consolidated POT. This includes the definition of "master" and "slave" component attributes within both the SIM and BIM databases, how they integrate with the other overlapping software systems, where the unique ID for a component is generated and how this is persisted across different sources, particularly over time.

While there are clear benefits with the retrospective construction of both a SIM and a BIM, the real potential is only unlocked if the systems are successfully integrated and due consideration is given to the ongoing updating and maintenance of the digital assets.

Conclusion

Having appropriate and reliable information about an asset is pivotal for enabling asset management to support decision-making, planning and execution of activities and tasks of assets, particularly during operations and maintenance. But, having access to the right information at the right time, has been and remains a pervasive problem. This has hindered an asset owner's ability to ensure their rail infrastructure performance is optimized and also threatens its resilience. Inaccurate and incomplete asset information unnecessarily exposes an asset owner to risks, which can be difficult to determine. In the case of electrical systems, the research presented in this paper demonstrated that the use of CAD to create, document and manage information was an unreliable medium and therefore resulted in the integrity of assets being jeopardized.

To address this problem, a technological alternative to CAD, referred to as System Information Modelling, which enables a 1:1 relationship between the real world and the digital model to be created was proposed. However, prior to introducing the SIM and its role in enabling DAM, the inherent problems associated with 'as-built' documentation of electrical systems were empirically quantified using the Bayswater railway station, which will form an integral part of the new Forrestfield Airport Link line. A retrospective SIM is developed and it contributes to reducing errors, omissions, and information redundancy throughout an asset's life-cycle.

The semantic and geometric information contained with the SIM and BIM, respectively, were linked using an IFC. Then, the SIM was mapped to PTA's asset management software system to enable the engineering and documentation data to be effectively transferred so it can be used during the operations and maintenance phases. Undertaking this process, however, enabled a number of problems to be identified, which otherwise would have been overlooked if this research had not been undertaken, these being a lack of guidelines that specify the objects to be modelled and the use of standardized naming conventions and IDs. Providing asset managers with this remit and ensuring that they are consulted and involved when specifying

the nature and format of information at the beginning of an asset's life cycle will make a positive contribution to the future-proofing process.

The PTA has recognized the potential of using a SIM and has begun to adopt this new way of working as part of a strategy to engage with the digital future. Naturally, technological innovations such as a SIM that is incongruous with established work practices is often confronted with strong scepticism and a lack of legitimacy. But, how such legitimacy is created and enacted within the organization and throughout their supply-chain will not automatically result from championing DAM enabled by a SIM through its advocacy, but also empirically identifying the failure and bottlenecks with using software systems that are not object-oriented in nature.

Acknowledgments: The authors would like to acknowledge the funding provided by the Australian Research Council (DP160102882), which has contributed, in part, to supporting the research presented in this paper. The authors would also like to thank Public Transport Authority and I&E Systems Pty Ltd for their financial support.

References

- ARA (2015). *Australasian Rail Association Submission to Infrastructure Australia on the Infrastructure Audit*. Australasian Rail Association Submission Accessed 30th August 2017, Available at: <https://ara.net.au/sites/default/files/Infrastructure%20Australia%20-%20Audit%20Submission.pdf>
- APSC (2012). *Tacking Wicked Problems: A Public-Sector Perspective*. Contemporary Government Challenges Australian Public Service Commission Commonwealth of Australia, Barton, ACT Australia Accessed 28th August, Available at: <http://www.enablingchange.com.au/wickedproblems.pdf>
- Blockley, D. (2005). Finding resilience through practical wisdom. *Civil Engineering and Environmental Systems*, **32**(1/2), pp.18-30.
- BS 1192-4:2014 Collaborative production of information. Fulfilling employer's information exchange requirements using COBie. Code of practice. BSI, B/555, p.58
- Coulton, M. (2016). Cost overruns the new norm for transport projects. *The Australian*, 2nd December 2016, Accessed 2nd September, Available at: <http://www.theaustralian.com.au/national-affairs/state-politics/cost-overruns-the-new-normal-in-transport-projects/news-story/b73a56a972e8b052d0d2ed2b72b50280>

- East, E. W. (2013). Electrical System information exchange (Sparkie). buildingSMART alliance, National Institute of building Sciences, Washington, DC. Accessed 4th September 2017, Available at; http://www.nibs.org/?page=bsa_sparkie
- Gallaher, M.P., O'Connor, Dettbarn, J.L. and Gilday, L.T. (2004). Cost Analysis of Inadequate Interoperability in the US Capital Facilities Industry, US Department of Commerce Technology, Administration, National Institute of Standards and Technology, Gaithersburg, MD.
- Gerring, J. (2005) *Case Study Research*. Cambridge University Press, New York
- Lui, J. Love, P.E.D., Smith, J., Matthews, J., and Sing, C.P. (2016). Praxis of performance measurement in Public-Private Partnerships: Moving beyond the iron triangle. *ASCE Journal of Management in Engineering* **32**(4) (ASCE)ME.1943-5479.0000433
- Lui, J. Love, P.E.D., Smith, J., Matthews, J., and Sing, C.P. (2017). Evaluation of Public-Private Partnerships: A life-cycle performance prism for ensuring value for money *Environment and Planning C: Politics and Space* (In press)
- Love, P.E.D. Zhou, J., Sing, C-P. and Kim, J.T. (2013). Documentation errors in instrumentation and electrical systems: Toward productivity improvement using system information modelling. *Automation in Construction*, **35**, pp.448-459.
- Love, P.E.D, Zhou, J., Matthews, J., Carey, B., and Sing, C.P (2015). A systems information model for managing electrical, control, and instrumentation assets. *Built Environment and Asset Project Management*, **5**(3), pp.278-288.
- Love, P.E.D., Zhou, J., Matthews, J., and Luo, H. (2016). System Information Modelling: Enabling digital asset management. *Advances in Engineering Software*, **102**, pp.155-165.
- Love, P.E.D., Zhou, J., Matthews, J. and Luo, H. (2016). Object oriented modeling: Retrospective systems information model for constructability assessment. *Automation in Construction*, **71**, pp.359-371.
- Love, P.E.D., Zhou, J. Irani, Z., Edwards, D.J. and Sing, C.P. (2017b). Off the rails: cost performance of rail infrastructure projects. *Transportation Research Part A: Policy and Practice*, **99**, pp.14-29.
- NCCARF (2013). Climate Proofing Australia's Infrastructure. Guidance Document No.7, National Climate Change Adaptation Research Facility, Accessed 30th August 2017, Available at: https://www.nccarf.edu.au/sites/default/files/attached_files_publications/INFRASTRUCTURE_A4-Webview.pdf
- Prior, G. (2017). Crossrail confirms £1bn extra cost of major contracts. *Construction Enquirer* Accessed 2nd September 2017, Available at:

<http://www.constructionenquirer.com/2017/08/07/crossrail-confirms-1bn-extra-cost-of-major-contracts/>

- Productivity Commission (2014). *Public Infrastructure: Productivity Inquiry into Public Infrastructure Report*. No. 71, Productivity Commission, Australia, Accessed 10th August 2017, Available at <http://www.pc.gov.au/inquiries/completed/infrastructure/report>
- Sacks, R. and Barak, R. (2008). Impact of three-dimensional parametric modeling of buildings on productivity in structural engineering practice. *Automation in Construction* **17**(4), pp.339-349
- Singh, I. (2017). BIM adoption and implementation around the world: Initiatives by major nations. *Geospatial World*, 5th April 2017 Accessed 30th August, Available at: <https://www.geospatialworld.net/blogs/bim-adoption-around-the-world/>
- Spagnolo, J. (2007). Perth's new rail link takes a leap into the future. *Sunday Times*, 12th March 2007, Accessed 2nd September 2017, Available at: <http://www.perthnow.com.au/news/western-australia/perth-goes-underground/news-story/4bb54a78cccfa17438fea1f388621ad6>
- Stacks, D.W. (2013). *Case Study*. In Heath, R. L.(Ed.) *Encyclopaedia of Public Relations*. Sage Publications.
- Teicholz, P. (2013). *BIM for Facility Managers*. Wiley and Sons, Hoboken, NJ.
- Terrill, M. and Danks, L. (2016). *Cost Overruns in Transportation Infrastructure Projects*. A Grattan Institute, Melbourne, Victoria, Australia, Available at; <https://grattan.edu.au/report/cost-overruns-in-transport-infrastructure/>, Accessed 12th December 2016
- Verweij, M., Douglas, M., Ellis, R., Engl, C., Hendriks, F., Lohmann, S., Ney, S., Rayner, S., and Thompson, M. (2006) *The Case for Clumsiness*. Clumsy Solutions in a Complex World, Springer, pp.1-27.
- Wiggins, J. (2016). Crossrail lessons timely for Australian rail projects. *The Sydney Morning Herald* 28th March, Accessed 3rd September 2017, Available at: <http://www.smh.com.au/business/crossrail-lessons-timely-for-australian-rail-projects-20160322-gnompm.html>
- Yin, R.K. (2014). *Case Study Research: Design and Methods*. 5th Edition. Sage Publications. California,
- Zhou, J., LOVE, P.E.D., Matthews, J., Carey, B. and Sing, C-P. (2015). An object-oriented model for life cycle management of electrical instrumentation control projects. *Automation in Construction*, **49**, pp.142-151