

Derivation of Suitability Metrics for Remote Access Mode Experiments

E.D. Lindsay¹, S.J. Murray², D.B. Lowe², T. Kostulski² and S.W. Tuttle²

¹ Curtin University of Technology, Department of Mechanical Engineering, Perth, Australia

² The University of Technology Sydney, Centre for Real-time Information Networks, Sydney, Australia

Abstract—When considering the possible use of an online mode of experimentation it is important to evaluate the suitability of the remote access mode to a particular learning exercise. Within a large and diverse set of possible experiment-oriented learning exercises, it follows that not all laboratory experiments are well-suited for conversion to the remote access mode. In this paper we consider a range of factors that should be considered before the decision is taken to implement a remote laboratory. These factors fit broadly into four categories: learning factors, equipment factors, cohort factors and accreditation factors. Some of the factors may demonstrate a tendency to belong to more than one category, and some may present with a more significant weighting than others, but the categorical organization of the factors adds an ability to apply an objective assessment to remote access mode suitability.

Index Terms— Remote laboratory, conversion, suitability, learning factors.

I. INTRODUCTION

Remote laboratories have seen accelerated development over approximately the past fifteen years (see, for example, LabShare's Sahara [1, 2], MIT's iLabs [3], LiLa [4] iLough-Lab [5], VISIR [6], WebLab-Deusto [7], NetLab [8], and Control Lab Online [9], amongst many others). While the designs and implementations of the various underlying infrastructure choices have been varied [10], there has been an observable similarity in the deployment or selection of remotely accessible practical learning exercises. It is clear that there has been an identifiable trend towards adopting a laboratory learning exercise which has a heritage and established legacy in the face-to-face mode and using technological solutions to make it feasible to access remotely. This particular approach is rational if one considers that the original (proximate) laboratory learning exercise may have a demonstrated capacity to deliver on learning outcomes, but it might also overlook accommodating some of the subtleties which a remote access mode necessarily entails.

This paper offers a more objective approach to the selection of practical learning exercise candidates for conversion to a remote access mode. The essential thrust is to examine the learning exercise from the perspective of its contributions in respect of four influential factors:

Learning factors;
Equipment factors;
Cohort factors; and
Accreditation factors.

The paper defines and describes each of these categories in detail, noting in particular that factors may appear in multiple categories. For example, group size in a scenario where students collaborate to complete an experiment can be both a learning factor (there being good educational justifications as to why a certain group size might be desirable) and a cohort factor (given the practicalities associated with managing different numbers of enrolled students). The factors as presented are intended to be a comprehensive but not exhaustive list of factors. It should provide guidance to educators when considering possible adoption of a remote access form of a laboratory exercise which is currently presented to students in the proximate form.

The first three categories deal with the suitability of specific laboratory exercises for conversion to the remote access mode. The fourth category deals more generally with how remote laboratories potentially impact upon a degree program's accreditation. To illustrate this impact two well-known criteria will be used – the Engineers Australia Accreditation Criteria [11] and the Accreditation Board for Engineering and Technology (ABET) Criteria [12].

The final section demonstrates the application of the suitability metrics to a sample generic laboratory exercise, with the intention of making an objective appraisal of its suitability as a candidate for conversion to a remote access mode.

II. LEARNING FACTORS

Ultimately, the most important question in any laboratory class is whether the students would learn as well or as much from the remote implementation as they can in the face-to-face mode. Not all learning outcomes can be achieved as well (if at all) through a remote interface; while others can in fact be better achieved through introducing separation between the students and the equipment [13].

Learning outcomes will fit generally into one of four categories:

1. Outcomes that cannot be achieved in the remote mode;
2. Outcomes that are less easily achieved in the remote mode;
3. Outcomes that are more easily achieved in the remote mode; and

4. Outcomes that are achievable only in the remote mode.

Laboratories whose learning outcomes fall primarily in categories 3 and 4 are suitable for conversion; laboratories whose learning outcomes fall primarily in categories 1 and 2 are not. (It should be acknowledged there may be other imperatives – such as funding or operational constraints – that drive the development of remote labs whose learning outcomes fall into category 2. For example an institution may simply not have the physical space to accommodate a laboratory that is educationally more effective in proximate mode than in remote mode, and so the substantive choice becomes one between no laboratory at all and a remote laboratory).

The full enumeration of learning outcomes, and the allocation of these outcomes to the four categories, is not always a straightforward task. Laboratory education serves a wide range of purposes, ranging from direct topic-specific technical information through to students' professional development as engineers. When considering the intended outcomes of the laboratory, the full range of factors must be considered.

It is unavoidable that some learning outcomes cannot be achieved as well (or at all) in the remote-access mode. Direct hands-on control of the equipment is impossible; and it must be determined whether this is a significant loss of a learning outcome.

It is important to consider what information needs to flow from the users to the equipment and back again. Video and audio signals can be streamed easily. Switches and dials can be implemented at a distance without difficulty. Haptic interfaces – elements such as pressure feedback – are potentially possible, but they require significant technical development to integrate into a remote operation platform. Temperature and smell are not possible to directly transmit to a remote user at this time. Not all laboratory experiences will rely upon the ambience of the physical laboratory, but those that do cannot rely upon it being recreated in whichever physical environment the students choose to access their remote laboratory.

The amount and nature of data required from the equipment will affect the suitability for conversion. For experimental apparatus which have much of their data in an already digitized form; it is a relatively simple matter to provide an option for students to simply download the data rather than take their own observational measurements. Downloading will facilitate the subsequent production of accurate graphs; however it will potentially undermine the mental processing that goes with the recording of data. For large data samples, however, manual collection of data can be onerous, and automating this collection via the remote interface can be an argument for suitability of conversion.

Remote access can also better support taking multiple measurements separated by a time interval, particularly if this time interval is longer than a traditional face-to-face laboratory class. This allows for a multi-stage analysis to be performed – perhaps a coarse-grained data collection to cover a full operating regime, and then a more fine-grained follow up to determine the exact location of an optimum. This measure-reflect-measure cycle is well supported in the remote mode; experiments that make use of it are well suited for conversion.

The repeatability of the measurements is an important concern. Equipment that provides poor repeatability is unsuitable; similarly equipment that provides exact repeatability, so that subsequent runs cannot be distinguished, is also unsuitable. The concern is the believability of the measured data. Data that is inconsistent may be dismissed as noise in the interface; data that is excessively consistent may be considered to be the output of a numerical equation, rather than actual experimental data. Either phenomenon will undermine the students' engagement with the equipment, and thus the learning value of the experiment.

The ability to download measurements in bulk can also offer an advantage for integration with some kinds of laboratory assessment tasks. Laboratory reports often require students to embed their results from the experiment; rather than requiring students to record their own data, it is possible to provide them with downloads of values directly from the equipment.

It is essential to consider whether it is preferred that the students/experimenters participate in a group experience or an individual experience. An individual experience eliminates the opportunities to engage in cooperative learning with colleagues, and to develop group communication skills in a laboratory environment. Conversely, an individual experience allows a guarantee that each and every student has themselves been directly in control of the apparatus, rather than merely being an onlooker while others drive.

Increased access time and self-paced experimentation offers an opportunity to allow the students to learn in the way they wish, rather than the way in which the group they are allocated to chooses as its norm.

Technical models for collaboration in remote laboratories have been under development [8, 14], but currently the dominant model for interaction is the individual access mode. Certainly groups of students can gather around a single computer terminal; however this is potentially less appealing than groups of students grouped around a piece of equipment. If the interaction between students is an important part of the laboratory experience, it will complicate the development of the remote implementation, and make the laboratory less suitable for migration to a remote access mode.

Similarly, it is important to consider whether the supervision of a demonstrator is an important part of your laboratory. Demonstrators are a valuable resource to students. They answer questions from the students, and can also intervene preemptively if they anticipate problems. In addition to providing this support, they also provide the valuable perception of support – a student who does not call upon a demonstrator for help may nonetheless appreciate knowing that they opportunity was there if needed.

As with providing opportunities for students to collaborate with each other, providing opportunities for proper laboratory supervision are difficult in the remote access mode. Some of the anticipatory functions – such as preventing unsafe operating conditions – can be embedded into the interface. Other aspects – such as having someone on-call to answer student questions – require additional effort. If interaction with a demonstrator is an important part of the laboratory experience, it will complicate the

development of the remote implementation, and make the laboratory less suitable for remote implementation.

One of the great advantages of remote laboratories is their safety. They allow for risks present in a face-to-face laboratory to be eliminated, or for experiments that would otherwise be considered unsafe to be attempted. While increased safety is an advantage, there is a risk that these safety measures may be invisible to the participants. Safety in a laboratory setting is an important learning outcome, and there is a risk that the remote implementation will encourage students to take it for granted, rather than taking responsibility for their own actions. This balance must be considered when determining whether a remote implementation is appropriate.

One potential advantage of a remote implementation is flexibility in scheduling. Usually a face-to-face laboratory is of a fixed, pre-determined length. Depending upon the scheduling model used, remote access allows for variable length sessions. This can allow students who learn faster to finish quicker; more importantly it can allow students who require more time to take as long as is needed to complete the work.

III. EQUIPMENT FACTORS

The second set of factors to be considered is the equipment itself. The experimental rig will fall somewhere into one of three categories, in decreasing order of suitability:

- A new rig, that can be built from components designed to be easily remote controlled
- An existing rig that has been built from components that can be easily remote controlled
- An existing rig that will require extensive retrofitting to allow remote control

In order to operate remotely, all of the relevant physical variables need to be captured using a data acquisition board. Purpose-designing a new rig to use digital transducers will ensure that this data capture is simple and straightforward. Retrofitting analogue manual sensors such as pressure gauges will be much more complex.

Consumables are a key issue. Generally speaking, experiments that require consumables are less suitable for remote conversion than those that do not. Experiments that require consumables have a fixed maximum uptime – once the consumables have been expended, then the rig is no longer available for use. This impact can be mitigated by ensuring that a sufficiently large supply of the consumable in question is available; however there will still come a time where manual intervention is necessary. This intervention will need to be incorporated into the ongoing operation and maintenance plans for the rig, and will need to take into account how consumables will be replenished on weekends or during holidays.

Equipment that is potentially dangerous can be good candidates for remote access, insofar as hands-on access may be impossible. The technology-mediated interface can have safety protocols built in to prevent the transmission of dangerous commands, and the separation can mitigate the risk to the students in conducting the experiments.

In general, the more expensive a piece of equipment is, the more suitable it is for conversion to remote access. This depends largely upon the psychology of how students engage with remote equipment, in that they engage more favourably if they perceive that remote is the only access mode that could have been available to them. Inexpensive equipment can easily be provided to all students in a face-to-face setting; as such students will be wondering why this has not been done. Expensive equipment, however, cannot be made ubiquitous; this means that the remote access can be seen as a bonus opportunity, rather than as a denial of a face-to-face alternative.

It is preferable that equipment configured for a remote teaching laboratory be tasked solely to teaching, rather than being made available for research or other purposes. While other purposes can help to defray the cost of the equipment, whenever the rig is being used for these purposes it is unavailable for its remote teaching mission.

Equipment that shows good (but not perfect) reproducibility of results is best suited for remote access. The repeatability of measurements helps support the students' sense of "establishment reality" – the way in which they establish in their minds that the experiment is in fact real, and that the data is in fact correct [15].

Perfect reproduction can be a liability, suggesting to the students that there is in fact not a real piece of equipment, but rather with a simulation that will present the same response to the same data each time.

Poor repeatability can cause students to question the validity of the interface, rather than the data itself. If students do not believe that the remote interface is providing an accurate representation of the real experiment, then they will disengage and their learning outcomes will degrade considerably. This phenomenon is independent of whether the data is in fact accurate – rather, it depends upon what the students *perceive* to be occurring.

It is important to consider the nature of the measurement systems to be used in the rig – some sensors can suffer considerable variability and fluctuations, while other sensors use signal conditioning to average out these fluctuations to provide a steady, stable signal.

The downside of the on-demand access model is the way in which demand is distributed. While potentially demand can be spread 24/7, rather than only in the hours when a staffed physical laboratory can be hosted, the reality is that there will be peaks in demand that exceed those in a traditionally allocated face-to-face model. If the experimental rig suite does not offer sufficient copies of the equipment, then there will be excessive queues to access the equipment. These queues may in fact be seen as a breaking of the promise for greater access, and will eliminate the value offered by the flexibility. Unless sufficient copies of the equipment can be provided, the laboratory is not suited to remote conversion.

IV. COHORT FACTORS

A successful conversion to remote access also depends upon the nature of your student cohort.

The ability of your cohort to access the internet must be considered. Unless their access to high-speed internet is notably better than their access to the physical laboratory,

remote conversion will be seen as a backwards step. In considering their access it is important to include access from their homes, from their workplaces, and also the computing resources available to them on campus. If you are relying upon external access, then firewall and security implementation becomes complicated; if you are relying upon internal access, then you risk the students asking why they cannot just use the physical hardware face to face.

In addition to having the access to the internet, your cohort must also be comfortable doing so. Engineering students are generally more comfortable than the general population; however this does not mean that all will be able to easily adapt. Cohorts that have previously used remote laboratories will be better equipped to adapt to an additional remote laboratory.

Geographically distributed cohorts are well suited to remote access. The most obvious example of this is through universities with multiple campuses, but there are other less obvious manifestations. Cohorts with large numbers of students engaging in paid employment can also cause problems when it comes to scheduling in-person laboratories. In short, the more difficult it is to get your entire cohort together with the equipment for a face-to-face laboratory, the better suited the laboratory is to remote conversion.

Moving to an online implementation usually changes the nature or the scheduling from an allocated fixed time to an on-demand access model. With large cohorts, allocating all of the students to their specific laboratory session can be difficult, particularly if any attempts are made to adapt to the needs and desires of the students. An on-demand access model removes this scheduling problem, which can be a significant reduction in administrative burden for a large cohort.

One last benefit that remotely accessible online laboratories offer is a mechanism to satisfy the emerging requirement for students to experience international collaboration in working on group-oriented tasks [16]. Contemporary trends towards internationally based, intercultural teams working jointly on projects in the workplace introduce new practice-oriented demands on graduates. Remote laboratories are a convenient and contextually appropriate way to provide students with these skills.

V. ACCREDITATION FACTORS

A. Engineers Australia

The Engineers Australia accreditation process utilizes 21 accreditation criteria, grouped into three categories: The Operating environment, The Academic program, and Quality Systems. Each of these 21 criteria have multiple performance indicators that can be used to demonstrate that the program satisfies the criteria.

Accreditation criteria are intended to be measured at the program level, to determine holistically whether graduates of that program will be equipped with the skills that they need. As such not all of the criteria are relevant to remote laboratories, and the discussions which follow, the subsets of the accreditation criteria which are not directly related have been omitted.

1) Category One: The operating environment

Three of the criteria have strong links to the positioning of remote laboratory learning in programs:

Academic leadership and educational culture

The performance indicators for this criterion include "Progressive pedagogical framework, adoption of best practice." There are arguments to support that remote laboratories are a superior way of delivering some learning outcomes [13], and as such their adoption is supported by this criterion.

Facilities and physical resources.

The performance indicators for this criterion include "Appropriate experimental and project based facilities to support both structured and investigatory learning within the specified field of practice and specialisation." The key is the interpretation of the word appropriate – well designed facilities will support these outcomes, regardless of mode.

Funding.

Funding has often been used as a driver for motivating remote access laboratories; however it does not intrinsically support or prevent remote laboratories.

2) Category Two: Academic Programs

Again, three of the criteria have strong links

Specification of educational outcomes.

As part of the development of any good remote laboratory class it is necessary to make explicit the learning objectives of the experiment; this assists in ensuring that educational outcomes can be specified.

Program structure and implementation framework.

The performance indicators for this criterion include "Flexible structure adaptable to student backgrounds and individual learning abilities." Remote laboratories certainly allow for a more flexible delivery for students, and allows for the differing non-academic commitments that come from a wide variety of backgrounds to be worked around.

Curriculum.

The performance indicators for this criterion clearly indicate that "practical and hands-on experience" are an essential program requirement. This performance indicator is broken down into a list of ten attributes that must be developed in a graduate:

1. an appreciation of the scientific method, the need for rigour and a sound theoretical basis;
2. a commitment to safe and sustainable practices;
3. skills in the selection and characterisation of engineering systems, devices, components and materials;
4. skills in the selection and application of appropriate engineering resources tools and techniques;
5. skills in the development and application of models;
6. skills in the design and conduct of experiments and measurements;
7. proficiency in appropriate laboratory procedures; the use of test rigs, instrumentation and test equipment;

8. skills in recognising unsuccessful outcomes, diagnosis, fault finding and reengineering;
9. Skills in perceiving possible sources of error, eliminating or compensating for them where possible, and quantifying their significance to the conclusions drawn;
10. skills in documenting results, analysing credibility of outcomes, critical reflection, developing robust conclusions, reporting outcomes.

Some of these attributes are equally achievable in the remote or in-person mode; others, such as number seven can be degraded if the interpretation of the word "use" is a hands-on unmediated control. There is evidence to suggest that the outcomes suggested in point number ten are in fact improved by the shift to the remote mode [13].

Ultimately it is the balance of these attributes, and the mix of in-person and remote laboratories used to achieve them, that will determine the suitability of the overall degree program for accreditation.

3) Category Three: Quality Systems

Most of the criteria have either no direct relevance, or only marginal relevance, to remote laboratories – however, two of the criteria have stronger links:

Processes for setting and reviewing the educational outcomes specification.

As part of the development of any good remote laboratory class it is necessary to make explicit the learning objectives of the experiment; a move to remote laboratories will make this explication part of the normal operating procedures.

Management of alternative implementation pathways and delivery modes.

The performance indicators for this criterion include "Adequate processes for analysing, monitoring and ensuring the equivalence of alternative implementation pathways and delivery modes." By their nature remote laboratories constitute an alternative delivery mode; provide they are adequately monitored they are not an impediment to accreditation.

In summary – from the Engineers Australia perspective, remote laboratory learning can be considered to make a valuable contribution, once the requirement that a thorough analysis of the desired learning outcomes has been accommodated.

B. ABET

The ABET accreditation is based upon nine criteria; eight general criteria and a ninth that is tailored to the nature of the specific program.

Many of the criteria are unrelated, or at best only marginally related, to remote laboratories. As before, only the criteria which are significant in the context of remote laboratories are presented and discussed. Three of the criteria have limited applicability to remote laboratories:

Criterion Two (Program Educational Objectives) – a well-managed transition to remote access often involves an explicit definition of learning objectives, but otherwise unrelated

Criterion Four (Continuous Improvement) – unrelated, save for considering alternative access modes is evidence of actions to improve a program

Criterion Eight (Support) – all facilities need to be adequately supported, regardless of whether they are remote; although resource-based issues may be a driver for implementation

Two of the criteria are linked implicitly to remote laboratories:

Criterion Three (Program Outcomes)

The question of what a graduate must be able to do after completion of the program is core to the design of that program; what remote laboratories can help accomplish in the process depends upon the kind of program outcome being considered.

"Engineering programs must demonstrate that their students attain the following outcomes:

(a) *an ability to apply knowledge of mathematics, science, and engineering*

(b) *an ability to design and conduct experiments, as well as to analyze and interpret data*

(c) *an ability to design a system, component, or process to meet desired needs within realistic constraints such as economic, environmental, social, political, ethical, health and safety, manufacturability, and sustainability*

(d) *an ability to function on multidisciplinary teams*

(e) *an ability to identify, formulate, and solve engineering problems*

(f) *an understanding of professional and ethical responsibility*

(g) *an ability to communicate effectively*

(h) *the broad education necessary to understand the impact of engineering solutions in a global, economic, environmental, and societal context*

(i) *a recognition of the need for, and an ability to engage in life-long learning*

(j) *a knowledge of contemporary issues*

(k) *an ability to use the techniques, skills, and modern engineering tools necessary for engineering practice.*

Program outcomes are outcomes (a) through (k) plus any additional outcomes that may be articulated by the program. Program outcomes must foster attainment of program educational objectives. There must be an assessment and evaluation process that periodically documents and demonstrates the degree to which the program outcomes are attained." [17]

Only some of the sub-criteria are affected by the transition to remote access:

Sub-criterion (b) is directly relevant; the ability to conduct experiments can be affected by the way in which the students experience their experiments. The full impact, however, will be affected more by the educational design of the experiment, rather than inherently changed by the remote-ness of the mode.

Sub-criterion (d) will likely be unsupported by remote labs given the current prevalence of solo remote laboratory experiences.

Sub-criterion (g) will be affected, in that the nature of the communications involved will be changed by the different access mode.

Sub-criterion (k) will be affected, in that remote control of hardware is a modern engineering tool, and remote laboratories inherently provide exposure to that environment.

Criterion Seven (Facilities):

“Classrooms, laboratories, and associated equipment must be adequate to safely accomplish the program objectives and provide an atmosphere conducive to learning. Appropriate facilities must be available to foster faculty-student interaction and to create a climate that encourages professional development and professional activities. Programs must provide opportunities for students to learn the use of modern engineering tools. Computing and information infrastructures must be in place to support the scholarly activities of the students and faculty and the educational objectives of the program and institution”. [17]

Remote laboratories provide an alternative mechanism to accomplish the program objectives. The issue of faculty-student interaction and professional development need to be addressed carefully, as these are often degraded in a remote implementation.

The use of modern engineering tools is clearly relevant for remote laboratories – remote operation of equipment is an increasingly prevalent industrial practice, and remote laboratories inherently expose students to this environment.

VI. APPLICATION OF THE METRICS

A sample laboratory experiment and apparatus are now considered, in order to demonstrate the metrics.

A. Active Network Synthesis:

Synthesise and implement the following delay equalizer function, using a summing four amplified biquad [18]:

$$\frac{V_{OUT}}{V_{IN}} = -\frac{s^2 - 500s + 25(10)^6}{s^2 + 500s + 25(10)^6}$$

The pre-work the students are to complete involves the development of the circuit diagram and a sensitivity analysis. A solution is the circuit shown in figure 1:

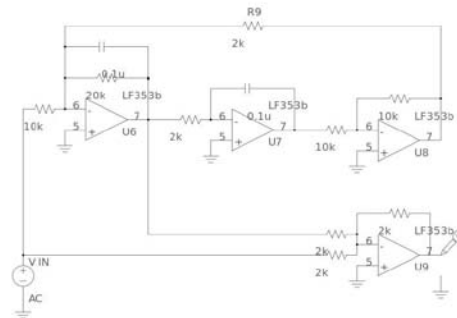

Figure 1 - Circuit for Construction and Test

The students are provided with the following instruments and equipment: A function generator, power supply, dual trace oscilloscope and a breadboard (figure 2)



Figure 2 – Equipment supplied for the Active Network Synthesis experiment

Briefly, the students in groups of three are to assemble the circuit on the breadboard supplied. This is checked by the laboratory tutor before power is applied, but the tutor only checks the assembled circuit for obvious safety hazards, not that the circuit is functionally correct.

On successful completion of the circuit construction, a frequency response is obtained within a suitable bandwidth (determined by the students). The next step is to exchange some of the components for ones that have similar values (within 20% of the designed values) and to observe the actual sensitivity performance at several stipulated operating points.

The final phase of the experiment involves disassembling the circuit and the preparation of a report.

B. Application of the Suitability Metrics:

1) Learning Factors

The learning outcomes are probably as easily achieved in the remote mode in this case. The type of information

flow and the amount of data required do not necessarily favor one mode over the other. The time interval between measurements is likely to be in the order of a few minutes and the measurements are not going to be directly repeatable with the same results. A critical factor is that the experiment is to be performed in groups and while this does not prohibit remote mode access, it introduces extra complexity. Another significant requirement is that the circuit be checked by the laboratory tutor – a factor easily facilitated by the proximate mode, but difficult in the remote mode.

2) Equipment Factors

This experiment does not require consumable resources, but almost every other factor is difficult to achieve in the remote access mode. The instruments would require significant interfacing effort, the circuit is to be assembled manually, dealing with low-voltage sources means that there is little danger involved in the proximate mode, the cost of the equipment is not extraordinary (it has already been borne in the case of this particular retro-fit feasibility assessment).

3) Cohort Factors

The experiment is to be completed by groups of students, but it is not a complex enough task to benefit from internationalization of the group cohorts. The students completing an experiment of this type are likely to be mid-level engineering undergraduates who would be comfortable using the Internet, but may not have had extensive experience in remote laboratory experimentation.

4) Accreditation Factors

Without the learning concepts being severely impacted, it is unlikely that the accreditation factors would contribute a significant argument for or against. It should be noted that the skills acquired by the students in constructing their own bread-board implementations of circuit prototypes would be forfeited if in the remote access mode, some type of advanced prototyping or assembly system was called upon to automate that particular task.

5) The overall evaluation

Whilst it may be technically possible to implement a remote access mode of this particular experiment, it would be unlikely to be cost-effective and would not offer a great reward in terms of student learning. This could be compared with a different scenario whereby a new laboratory experiment and apparatus might be under consideration for construction to support high-voltage experimentation. Such a situation could present greater opportunities for network interface hardware to be installed at the time of construction and the safety aspects of the use of the equipment is guaranteed by the remote access mode. High-voltage apparatus is specialized equipment and the expense of the initial capital outlay could be defrayed by constructing just one set of the equipment and apparatus and sharing it amongst contributing online users. Also, depending upon the particular type of experiment to be undertaken, it may not be unreasonable for students to access equipment and apparatus which is already configured and does not require them to complete any manual assembly.

VII. CONCLUSION

Not all experiments are equally suited for conversion to the remote access mode. This paper presents a framework using four significant factors – learning factors, equipment factors, cohort factors and accreditation factors – to assist in determining whether a particular experiment is suitable for implementation in the remote access mode. With further refinement resulting from continued practice in their application, the expressions of these suitability factors offer a way to add quality to remote access experimentation and to ensure that the most appropriate laboratory learning exercises are targeted.

REFERENCES

- [1] S. Murray, *et al.*, "Experiences with a Hybrid Architecture for Remote Laboratories," presented at the FiE 2008: The 38th Annual Frontiers in Education Conference, Saratoga Springs, USA, 2008.
- [2] D. Lowe, *et al.*, "Towards a National Approach to Laboratory Sharing," presented at the AAEE'09: 2009 Australasian Association for Engineering Education conference, Adelaide, Australia, 2009.
- [3] V. Harward, *et al.*, "The iLab shared architecture: A Web Services infrastructure to build communities of Internet accessible laboratories," *Proceedings of the IEEE*, vol. 96, p. 931, 2008.
- [4] D. Boehringer. (2010, 18/3/2010). *LiLa - Library of Labs*. Available: <http://www.lila-project.org/>
- [5] M. Abdulwahed and Z. Nagy. (2009, 18/3/2010). *iLough-Lab*. Available: <http://www.ilough-lab.com/>
- [6] I. Gustavsson, *et al.*, "The VISIR project—an Open Source Software Initiative for Distributed Online Laboratories," 2007.
- [7] J. Garcia-Zulbia, *et al.*, "Experience with WebLab-Deusto."
- [8] J. Machotka, *et al.*, "Collaborative Learning in the Remote Laboratory NetLab," *Journal of Systemics, Cybernetics and Informatics*, vol. 6, pp. 22-27.
- [9] J. Henry, "Controls laboratory teaching via the World Wide Web," 1996.
- [10] D. Lowe, *et al.*, "Evolving Remote Laboratory Architectures to Leverage Emerging Internet Technologies," *IEEE Transactions on Learning Technologies*, vol. 2, pp. 289-294, 2009.
- [11] A. Bradley. (2006). *Accreditation Criteria Guidelines*. Available: http://www.engineersaustralia.org.au/about-us/program-accreditation/program-accreditation_home.cfm
- [12] Accreditation Board for Engineering and Technology. (2009). *2010-2011 Criteria for Accrediting Engineering Programs*. Available: http://www.abet.org/forms.shtml#For_Engineering_Programs_Only
- [13] E. D. Lindsay and M. C. Good, "Effects of laboratory access modes upon learning outcomes," *Education, IEEE Transactions on*, vol. 48, pp. 619-631, 2005.
- [14] C. Gravier, *et al.*, "Coping with collaborative and competitive episodes within collaborative remote laboratories," 2008.
- [15] E. D. Lindsay, *et al.*, "Establishment reality vs maintenance reality: how real is real enough?," *European Journal of Engineering Education*, vol. 34, pp. 229-234, 2009.
- [16] A. Nafalski, "Enriching student learning experience through international collaboration in remote laboratories," Australian Learning and Teaching Council, 2008, pp. <http://www.altc.edu.au/project-enriching-student-learning-experience-unisa-2008>.
- [17] I. ABET, "Criteria for Accrediting Engineering Programs," Baltimore, ABET, 2005.
- [18] G. Daryanani, *Principles of active network synthesis and design*. Wiley New York, 1976.

Gelöscht: ¶

~~~~~Abschnittswechsel (Fortlaufend)~~~~~